

Pin	Signal Name	Mating Sequence	Pin	Signal Name	Mating Sequence
A1	GND	First	B12	GND	First
A2	SSTXp1	Second	B11	SSRXp1	Second
A3	SSTXn1	Second	B10	SSRXn1	Second
A4	V _{BUS}	First	B9	V _{BUS}	First
A5	CC1	Second	B8	SBU2	Second
A6	Dp1	Second	B7	Dn2	Second
A7	Dn1	Second	B6	Dp2	Second
A8	SBU1	Second	B5	CC2	Second
A9	V _{BUS}	First	B4	V _{BUS}	First
A10	SSRXn2	Second	B3	SSTXn2	Second
A11	SSRXp2	Second	B2	SSTXp2	Second
A12	GND	First	B1	GND	First
SHELL	GND		SHELL	GND	

NOTE:
 1. MATERIAL:
 1.1 INSULATOR: HIGH TEMPERATURE PLASTIC UL 94 V-0;
 1.2 CONTACT: COPPER ALLOY(T=0.15mm)
 1.3 SHELL: STAINLESS STEEL(T=0.20mm)
 2. ELECTRICAL CHARACTERISTICS:
 2.1 CONTACT RESISTANCE: 40mΩ Max FOR INITIAL. 10mΩ CHANGE AFTER TEST. MEASURE AT 20mV, 100mA.
 2.2 CONTACT CURRENT RATING: 5A FOR V_{BUS} PIN; 1.25A FOR VCONN PIN.
 2.3 DIELECTRIC WITHSTANDING VOLTAGE: 100V AC R.M.S.
 2.4 INSULATION RESISTANCE 100MΩ Min
 2.5 OPERATING TEMPERATURE: -40°C ~ 85°C
 3. MECHANICAL CHARACTERISTICS:
 3.1 MATING FORCE: 5~20 N.
 3.2 UNMATED FORCE: 8~20N AFTER TEST
 3.3 DURABILITY: 10,000 CYCLES
 4. PLATING
 4.1 TERMINAL CONTACT: (SEE TAB) GOLD PLATING ALL OVER 50u" Min NICKEL AND 80u"Min Tin ALL OVER 50u" Min NICKEL ON SOLDER AREA
 4.2 OUT SHELL: 50u" Min. NICKEL ALL OVER
 4.3 INNER SHELL: DEGREASE
 5. PART NUMBER:
 USB31-TYPEC-32X39-XFS

1: Tray 2: Tape reel
 39: IP67
 48: IP54
 49: 不防水
 1: G/F 2: 5u" 3: 10u"
 4: 15u" 5: 30u"

RECOMMEND P.C.B LAYOUT (COMPONENT SIDE)
 TOLERANCE FOR PCB LAYOUT IS ±0.05

MARK	DESCRIPTION	DATE	REVISED	APPROVED	ANGLAR	±5°	DSND	DATE	SCALE: N/A	MODEL TYPE:			
ΔX					L ≤ 4	±0.2	DWN	DATE	VIEW:	USB 3.1 TYPE			
ΔX					4 < L ≤ 16	±0.3	CHKD	DATE	UNIT: mm	PART NO.:			
ΔX					16 < L ≤ 63	±0.4	APPD	DATE	SIZE: A4	DWG NO.:			
					L > 63	±0.5				USB31-TYPEC-32X39-XFS			
REVISIONS							UNSPECIFIED TOLERANCES		XKB INDUSTRIAL PRECISION CO., LIMITED		WEIGHT	SHEET	REVISION
www.xk-dg.cn www.helloxkb.com www.helloxkb.cn											1.0g	1/1	A0

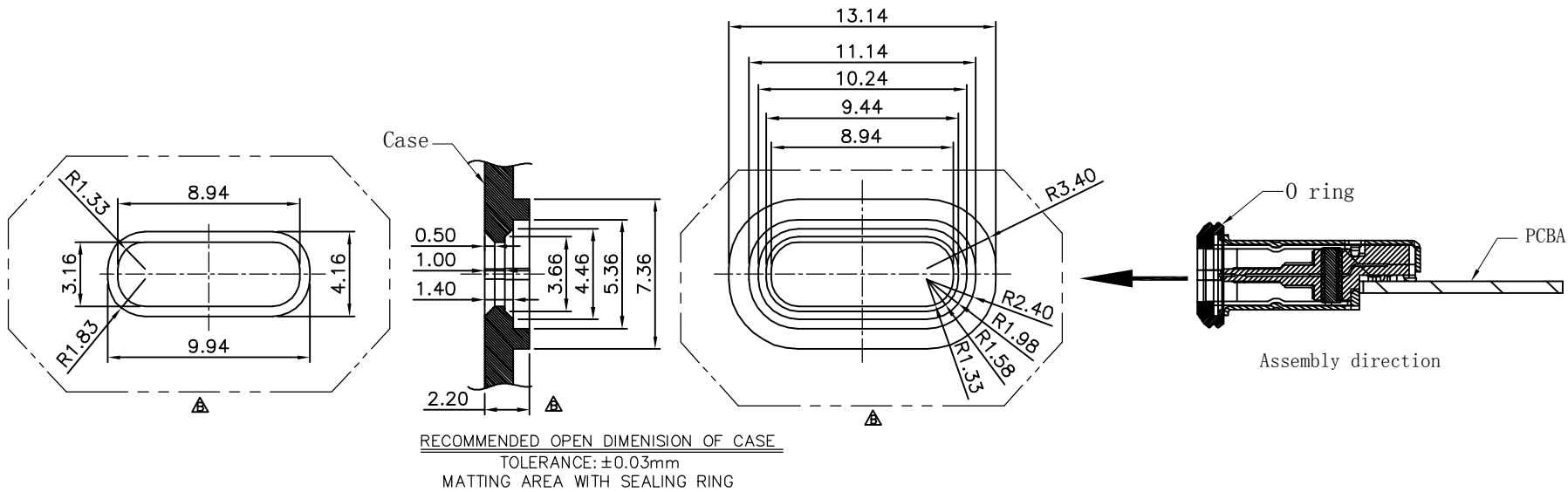
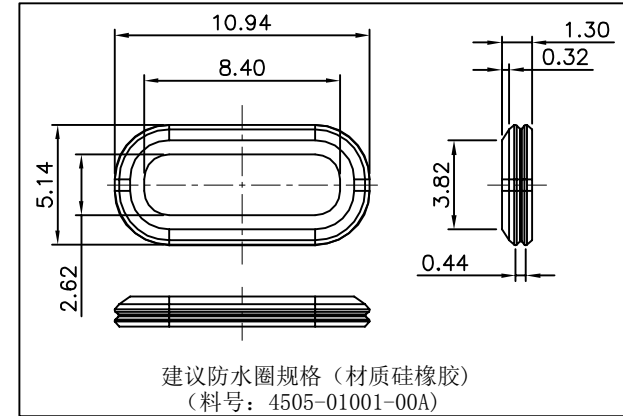
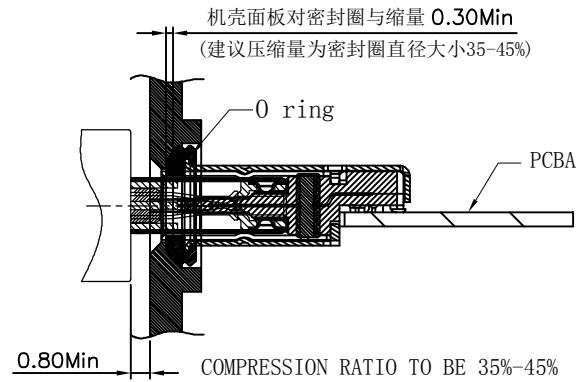

					DSND		DATE		SCALE: N/A	MODEL TYPE: USB 3.1 TYPE		
ΔX					ANGLAR	±5°	DWN	DATE	VIEW:	PART NO.:		
ΔX					L ≤ 4	±0.2	CHKD	DATE	UNIT: mm	DWG NO.:		
ΔX					4 < L ≤ 16	±0.3	APPD	DATE	SIZE: A4	USB31-TYPEC-32X39-XFS		
MARK	DESCRIPTION	DATE	REVISED	APPROVED	16 < L ≤ 63	±0.4				WEIGHT	SHEET	REVISION
					L > 63	±0.5				1.0g	1/1	A0
					UNSPECIFIED TOLERANCES				XKB INDUSTRIAL PRECISION CO., LIMITED			
www.xk-dg.cn www.helloxkb.com www.helloxkb.cn												

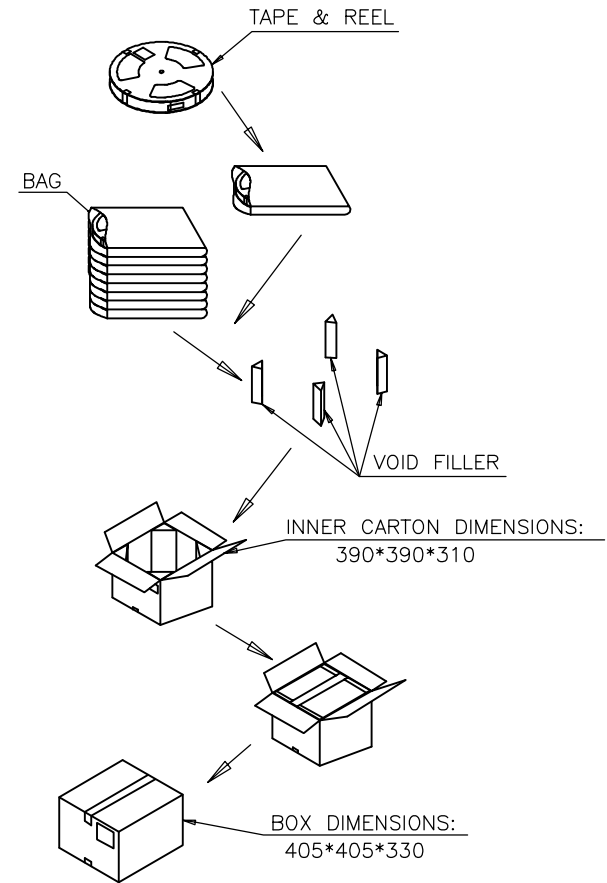
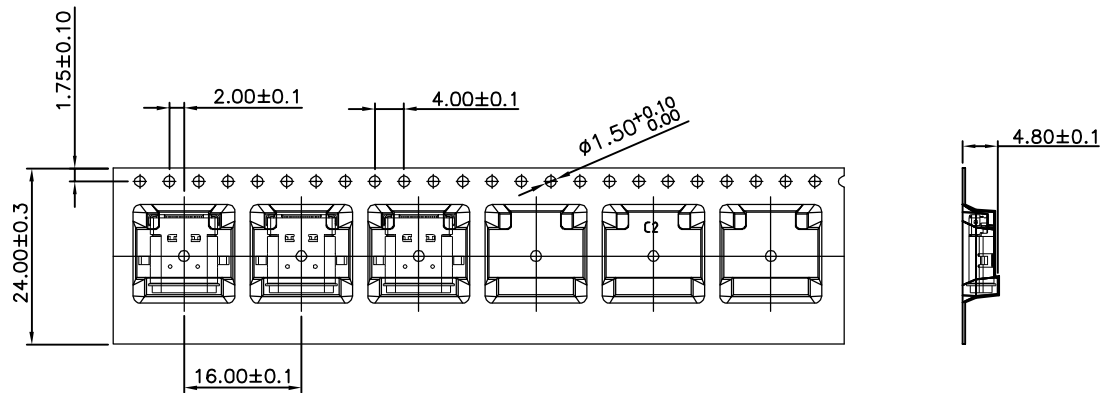
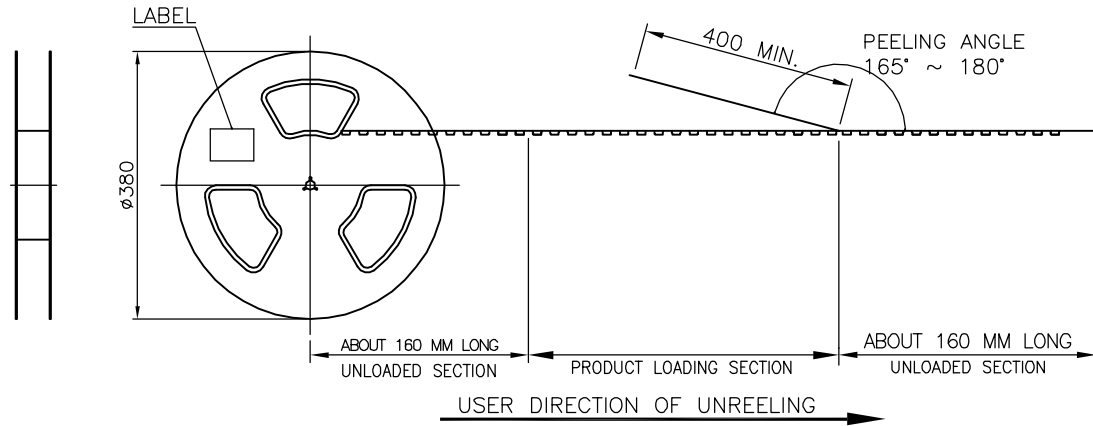

NOTE:

- 1.MATERIAL:
 BOX: FIBREBOARD, CORRUGATED, DOUBLE WALL.
 TAPE: POLYSTYRENES, HEAT-RESISTANT TEMPERATURE: 120°C, BLACK COLOR.
 REEL: POLYSTYRENES, HEAT-RESISTANT TEMPERATURE: 70°C, BLUE COLOR.
 BAG: POLYETHYLENE, HEAT-RESISTANT TEMPERATURE: 100°C.

2.PEELING STRENGTH: 0.1 ~ 1.3 N (10 ~ 130 GRAMS)

3.PEELING SPEED: 300 mm/min.

4.EACH BAG SHALL BE INCLUDED DESICCANT.

1000	10	10000 PCS	-- KG	-- KG
PCS/ REEL	REELS/ CARTON	QUANTITY	GROSS WEIGHT	NET WEIGHT

						DSND		DATE		SCALE: N/A	MODEL TYPE: USB 3.1 TYPE
						DWN		DATE		VIEW:	PART NO.:
						CHKD		DATE		UNIT: mm	DWG NO.: USB31-TYPEC-32X39-XFS
						APPD		DATE		SIZE: A4	
MARK	DESCRIPTION	DATE	REVISED	APPROVED	UNSPECIFIED TOLERANCES				XKB INDUSTRIAL PRECISION CO.,LIMITED		
REVISIONS									WEIGHT	SHEET	REVISION
www.xk-dg.cn www.helloxkb.com www.helloxkb.cn									1.0g	1/1	A0