

# 承 认 书

## SPECIFICATION FOR APPROVAL

|       |               |     |             |
|-------|---------------|-----|-------------|
| 客户名称: | 佛山电器照明股份有限公司  |     |             |
| 客户料号: | 18X001040024  |     |             |
| 产品名称: | MOSFET        |     |             |
| 产品型号: | 4N65TF        |     |             |
| 产品商标: |               |     |             |
| 环保要求: | ROHS2.0 REACH |     |             |
| 版 次:  | V1.0          |     |             |
| 拟制:   | 张少            | 日期: | 2018年07月21日 |
| 审核:   | 王兴龙           | 日期: | 2018年07月21日 |
| 批准:   | 王兴龙           | 日期: | 2018年07月21日 |
| 客户确认: |               |     |             |

地 址: 重庆市梁平县梁平工业园

电 话: 86-23-85709656

传 真: 86-23-85709677

e-mail: pwkefu@perfectway.cn

http://www.perfectway.cn



## 4N65TF

4 Amps,650 Volts N-CHANNEL MOSFET

### FEATURE

- 4A,650V, $R_{DS(ON)MAX}=2.6\ \Omega$  @ $V_{GS}=10V/2A$
- Low gate charge
- Low  $C_{iss}$
- Fast switching
- 100% avalanche tested
- Improved dv/dt capability

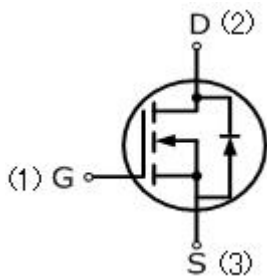

TO-220TF

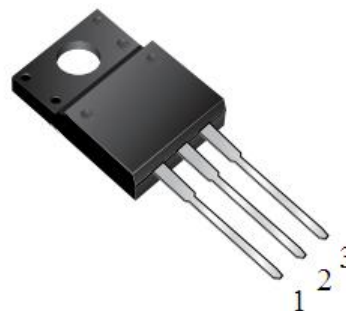

### Absolute Maximum Ratings( $T_C=25^\circ\text{C}$ , unless otherwise noted)

| Parameter  | Symbol           | 4N65TF      | UNIT             |
|--|------------------|-------------|------------------|
| Drain-Source Voltage   | $V_{DSS}$        | 650         | V                |
| Gate-Source Voltage  | $V_{GSS}$        | $\pm 30$    |                  |
| Continuous Drain Current   | $I_D$            | 4           | A                |
| Pulsed Drain Current(Note 1)   | $I_{DM}$         | 16          |                  |
| Single Pulse Avalanche Energy (Note 2)   | $E_{AS}$         | 150         | mJ               |
| Reverse Diode dV/dt (Note 3)   | dv/dt            | 2.63        | V/ns             |
| Operating Junction and Storage Temperature Range                                 | $T_J, T_{STG}$   | -55 to +150 | $^\circ\text{C}$ |
| Maximum lead temperature for soldering purposes,<br>1/8" from case for 5 seconds | $T_L$            | 260         | $^\circ\text{C}$ |
| Mounting Torque  | 6-32 or M3 screw | 10          | lbf • in         |
|  |                  | 1.1         | N • m            |

### Thermal Characteristics

| Parameter                 | Symbol     | MAX  | Units                     |
|---------------------------|------------|------|---------------------------|
| Maximum Junction-to-Case  | $R_{thJC}$ | 3.47 | $^\circ\text{C}/\text{W}$ |
| Maximum Power Dissipation | $P_D$      | 34   | W                         |

| <b>Electrical Characteristics</b> ( $T_c=25^\circ\text{C}$ , unless otherwise noted) |                                |   |     |      |      |                    |
|--|--------------------------------|---|-----|------|------|--------------------|
| Parameter  | Symbol                         | Test Conditions   | Min | Typ  | Max  | Units              |
| <b>Off Characteristics</b>   |                                |   |     |      |      |                    |
| Drain-Source Breakdown Voltage   | $BV_{DSS}$                     | $V_{GS}=0V, I_D=250\mu A$   | 650 | —    | —    | V                  |
| Breakdown Temperature Coefficient  | $\Delta BV_{DSS} / \Delta T_J$ | Reference to $25^\circ\text{C}$ ,<br>$I_D=250\mu A$                       | —   | 0.67 | —    | $V/^\circ\text{C}$ |
| Zero Gate Voltage Drain Current  | $I_{DSS}$                      | $V_{DS}=650V, V_{GS}=0V$  | —   | —    | 10   | $\mu A$            |
| Gate-Body Leakage Current, Forward   | $I_{GSSF}$                     | $V_{GS}=30V, V_{DS}=0V$   | —   | —    | 100  | nA                 |
| Gate-Body Leakage Current, Reverse   | $I_{GSSR}$                     | $V_{GS}=-30V, V_{DS}=0V$  | —   | —    | -100 | nA                 |
| <b>On Characteristics</b>  |                                |   |     |      |      |                    |
| Gate-Source Threshold Voltage  | $V_{GS(th)}$                   | $V_{DS}=V_{GS}, I_D=250\mu A$   | 2   | —    | 4    | V                  |
| Drain-Source On-State Resistance   | $R_{DS(on)}$                   | $V_{GS}=10V, I_D=2A$  | —   | 2.1  | 2.6  | $\Omega$           |
| Pulse width $t_p \leq 380\mu s$ , $\delta \leq 2\%$                                  |                                |   |     |      |      |                    |
| <b>Dynamic Characteristics</b>   |                                |   |     |      |      |                    |
| Input Capacitance  | $C_{iss}$                      | $V_{DS}=25V, V_{GS}=0V$ ,<br>$f=1.0\text{MHz}$                            | —   | 425  | —    | pF                 |
| Output Capacitance   | $C_{oss}$                      |   | —   | 55   | —    | pF                 |
| Reverse Transfer Capacitance   | $C_{rss}$                      |   | —   | 5.8  | —    | pF                 |
| <b>Switching Characteristics</b>   |                                |   |     |      |      |                    |
| Turn-On Delay Time   | $t_{d(on)}$                    | $V_{DD}=325V, I_D=4A$ ,<br>$R_G=10\Omega$<br>(Note3,4)                    | —   | 10   | —    | ns                 |
| Turn-On Rise Time  | $t_r$                          |   | —   | 11   | —    | ns                 |
| Turn-Off Delay Time  | $t_{d(off)}$                   |   | —   | 31   | —    | ns                 |
| Turn-Off Fall Time   | $t_f$                          |   | —   | 16   | —    | ns                 |
| Total Gate Charge  | $Q_g$                          | $V_{DS}=325V, I_D=4A$ ,<br>$V_{GS}=10V$ (Note3,4)                         | —   | 14.5 | —    | nC                 |
| Gate-Source Charge   | $Q_{gs}$                       |   | —   | 3    | —    | nC                 |
| Gate-Drain Charge  | $Q_{gd}$                       |   | —   | 6    | —    | nC                 |
| <b>Drain-Source Body Diode Characteristics and Maximum Ratings</b>                   |                                |   |     |      |      |                    |
| Diode Forward Voltage  | $V_{SD}$                       | $I_S=4A, V_{GS}=0V$   | —   | —    | 1.5  | V                  |
| Reverse Recovery Time  | $t_{rr}$                       | $V_{GS}=0V, I_S=4A, T_j=25^\circ\text{C}$<br>$dI_F/dt=100A/\mu s$ (Note3) | —   | 320  | —    | ns                 |
| Reverse Recovery Charge  | $Q_{rr}$                       |   | —   | 2.0  | —    | nC                 |
| Pulse width $t_p \leq 380\mu s$ , $\delta \leq 2\%$                                  |                                |   |     |      |      |                    |

### Notes

1. Repetitive Rating: pulse width limited by maximum junction temperature .
2.  $V_{DD}=50V$ , starling,  $L=18.8\text{mH}$ ,  $R_g=25\Omega$ ,  $I_{AS}=4A$ ,  $T_j=25^\circ\text{C}$ .
3.  $dI/dt=$ \_A/us, starting  $T_j=25^\circ\text{C}$ . Pulse width  $\leq 300\mu s$ ; duty cycle  $\leq 2\%$ .
4. Repetitive rating; pulse width limited by maximum junction temperature.

**TEST CIRCUIT AND WAVEFORM**

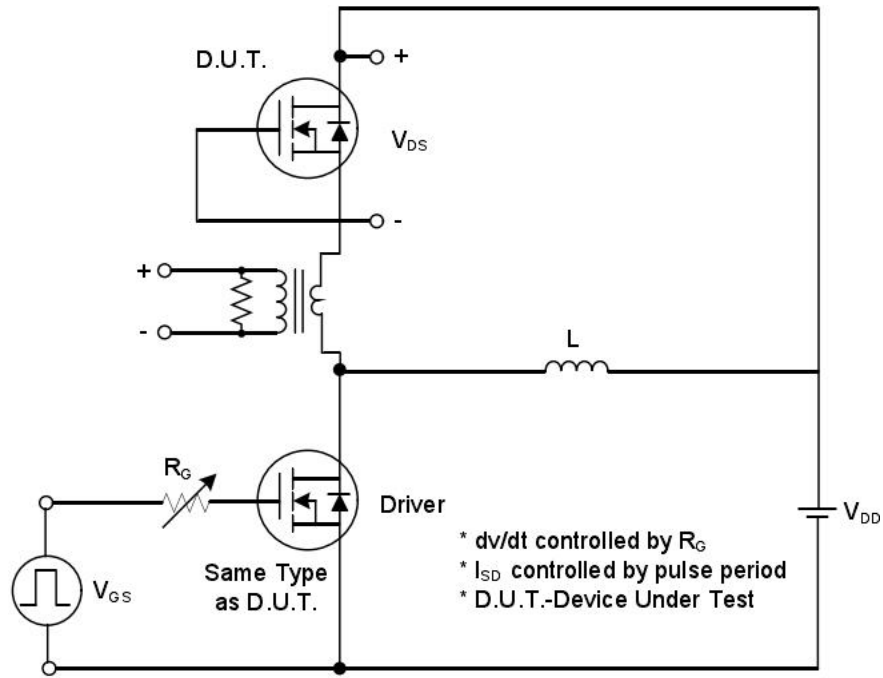

**Peak Diode Recovery  $dv/dt$  Test Circuit**

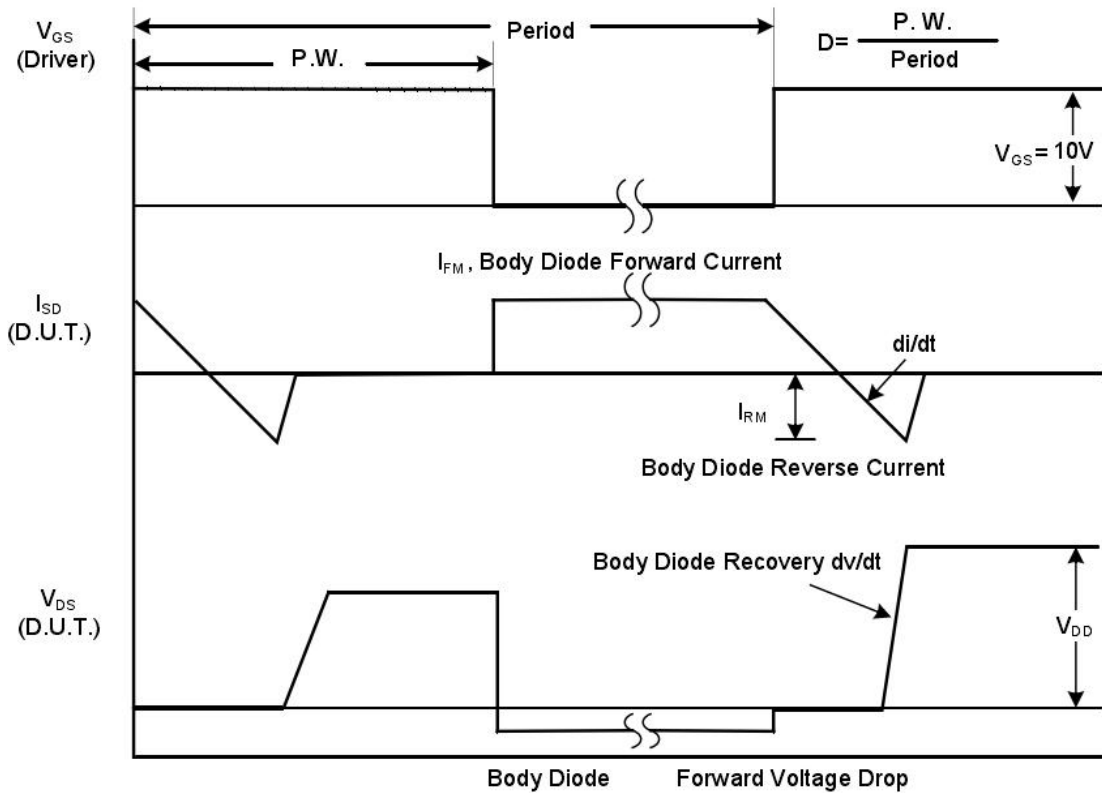

**Peak Diode Recovery  $dv/dt$  Waveforms**

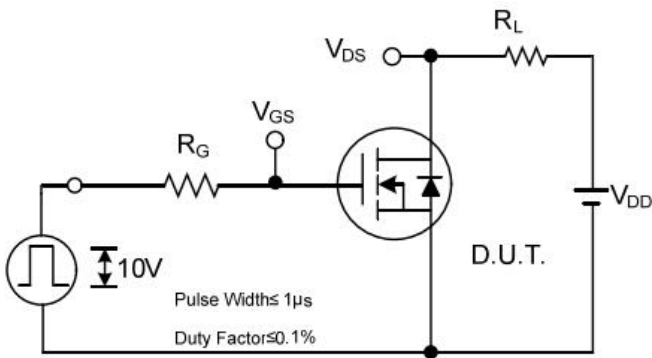

**Switching Test Circuit**

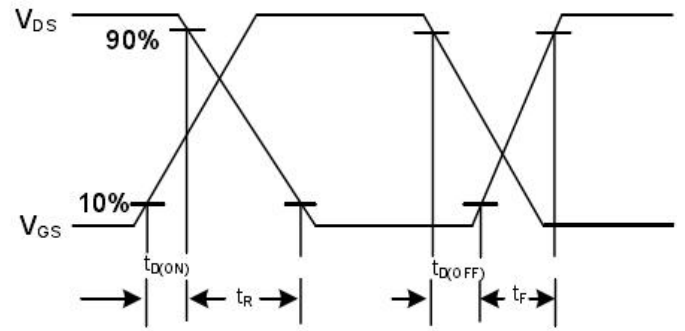

**Switching Waveforms**

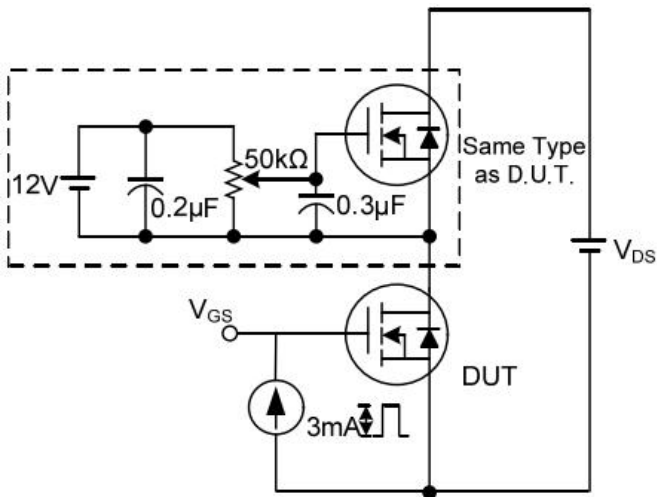

**Gate Charge Test Circuit**

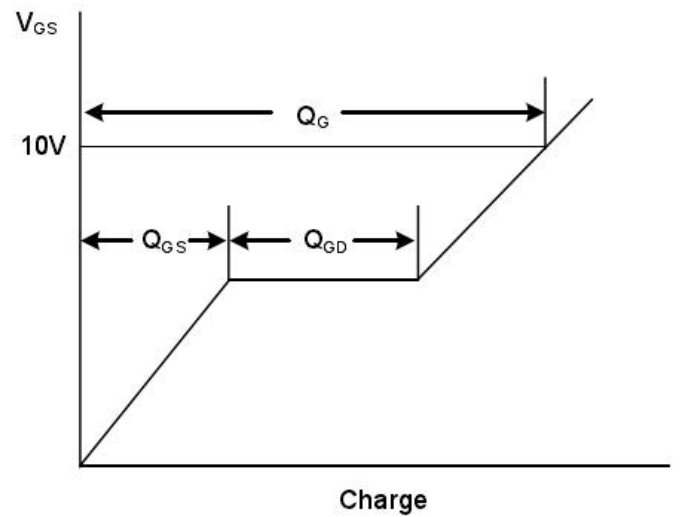

**Gate Charge Waveform**

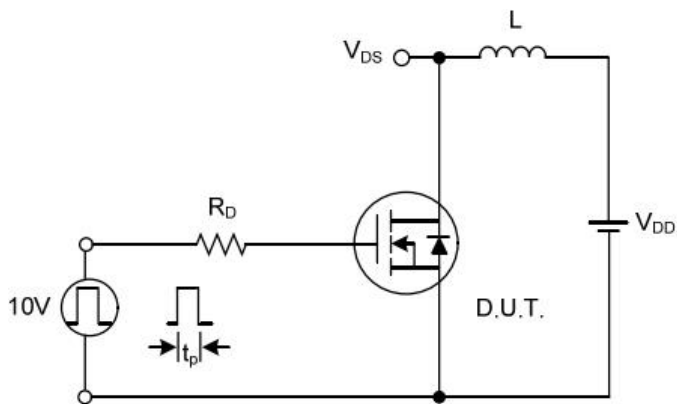

**Unclamped Inductive Switching Test Circuit**

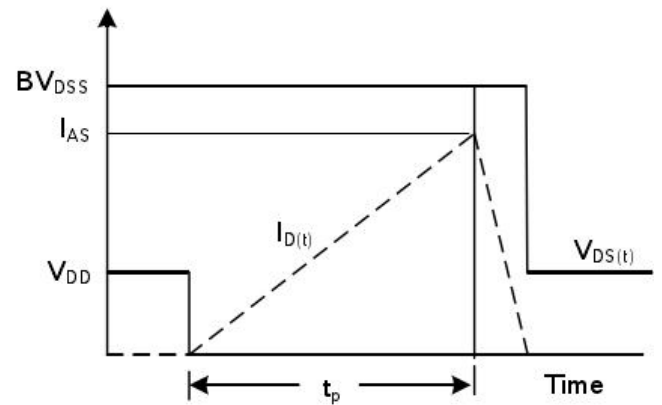

**Unclamped Inductive Switching Waveforms**

## RATING AND CHARACTERISTIC CURVES

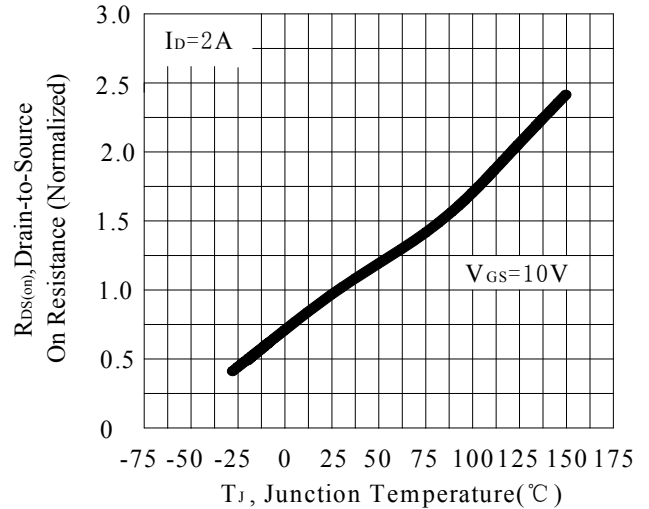
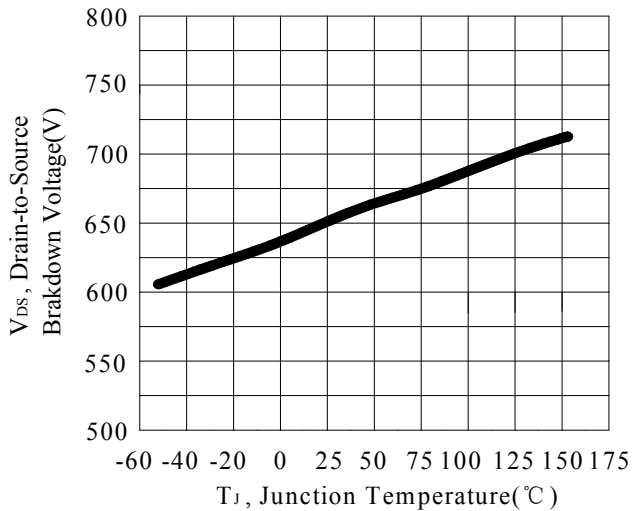
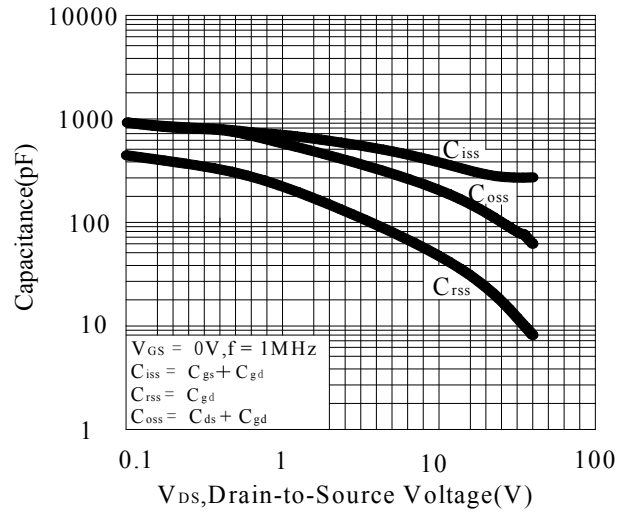
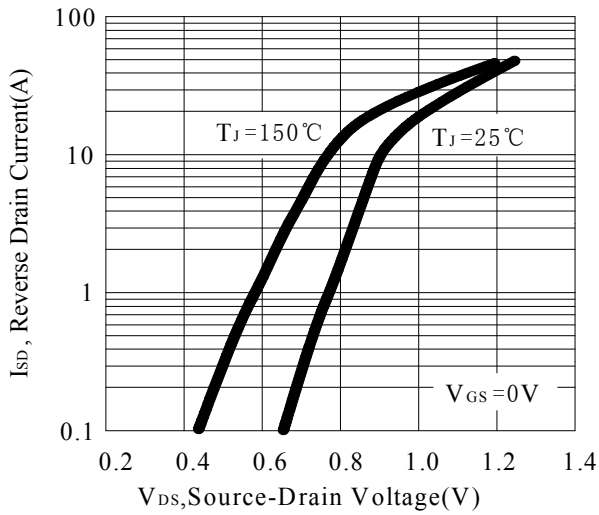
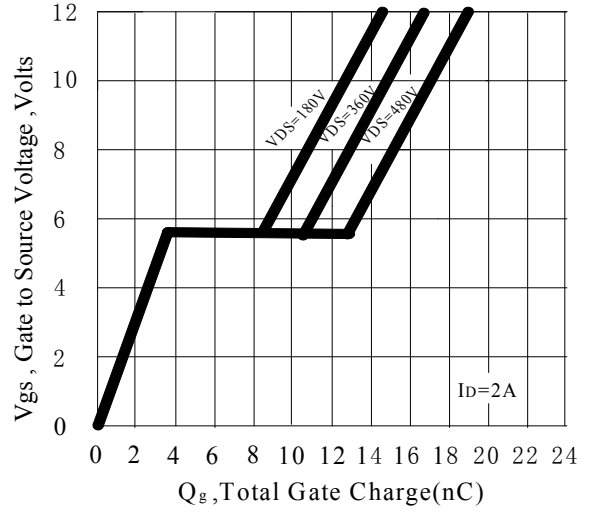
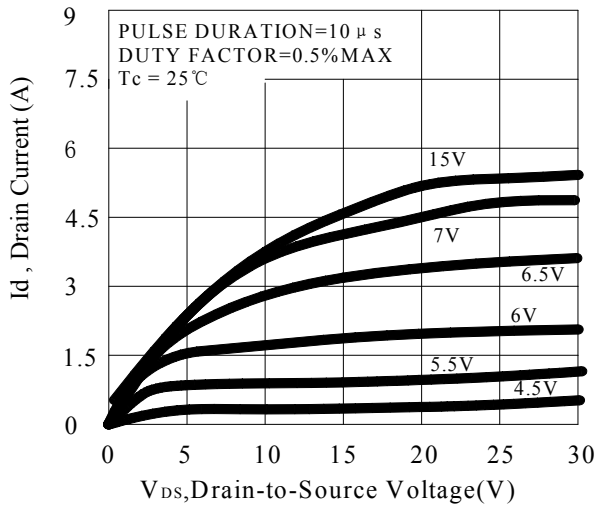

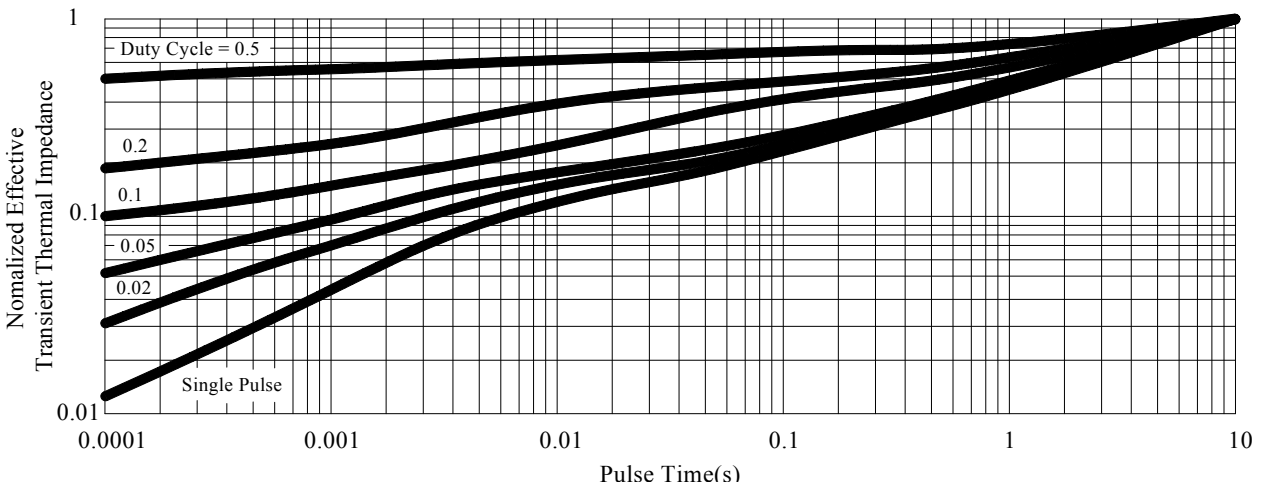
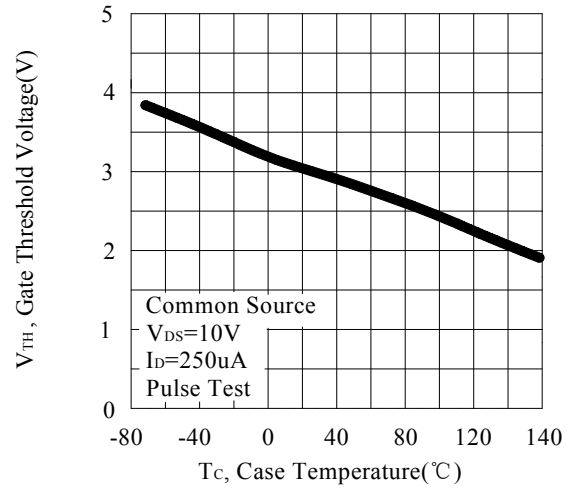
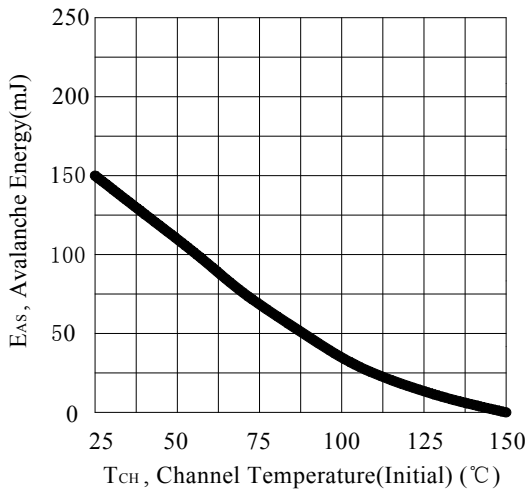
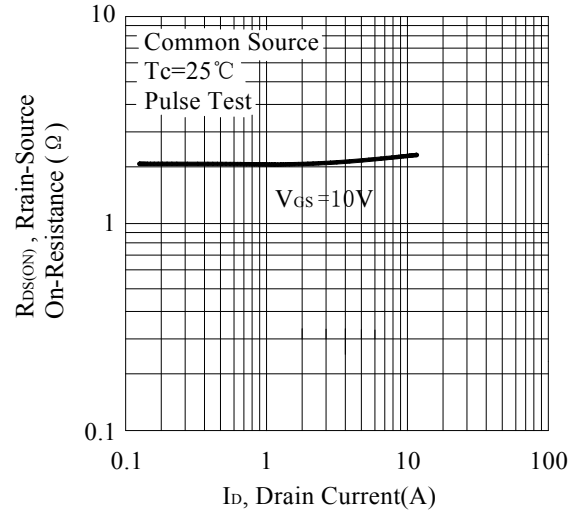
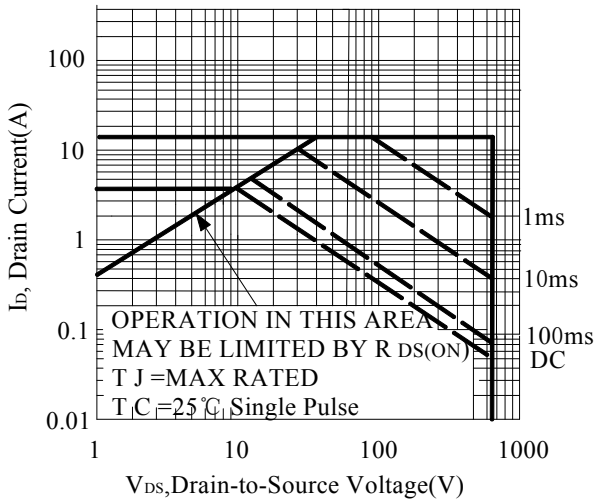

**PACKAGE OUTLINE DIMENSIONS**

**TO-220TF**

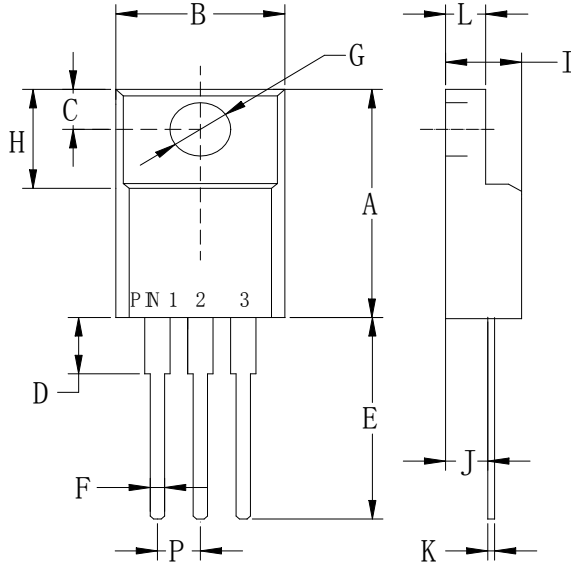

| TO-220TF |             |             |
|----------|-------------|-------------|
| Dim      | Min         | Max         |
| A        | .590 (15.0) | .650 (16.5) |
| B        | .393 (10.0) | .414 (10.5) |
| C        | .118 (3.00) | .138 (3.50) |
| D        | .118 (3.00) | .146 (3.70) |
| E        | .512 (13.0) | .551 (14.0) |
| F        | .028 (0.70) | .035 (0.90) |
| G        | .114 (2.90) | .138 (3.50) |
| H        | .255 (6.50) | .280 (7.10) |
| I        | .173 (4.40) | .197 (5.00) |
| J        | .102 (2.60) | .110 (2.80) |
| K        | .018 (0.45) | .026 (0.65) |
| L        | .092 (2.35) | .109 (2.75) |
| P        | .890 (2.25) | .113 (2.85) |