

8N06(G,D)

7.5 Amps,60 Volts N-CHANNEL MOSFET

FEATURE

- 7.5A,60V, $R_{DS(ON)MAX}=82m\ \Omega$ @ $V_{GS}=10V/4A$
 $R_{DS(ON)MAX}=107m\ \Omega$ @ $V_{GS}=4.5V/4A$
- Low gate charge
- Low C_{iss}
- Fast switching
- 100% avalanche tested
- Improved dv/dt capability

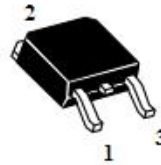
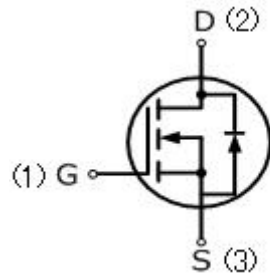

TO-252
8N06G

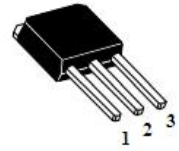

TO-251
8N06D

Absolute Maximum Ratings($T_C=25^\circ C$, unless otherwise noted)

Parameter	Symbol	8N06(G,D)	UNIT
Drain-Source Voltage	V_{DSS}	60	V
Gate-Source Voltage	V_{GSS}	± 20	
Continuous Drain Current	I_D	7.5	A
Pulsed Drain Current(Note1)	I_{DM}	11	
Single Pulse Avalanche Energy (Note 2)	E_{AS}	25	mJ
Operating Junction and Storage Temperature Range	T_J, T_{STG}	-55to+150	$^\circ C$
Maximum lead temperature for soldering purposes, 1/8" from case for 5 seconds	T_L	260	$^\circ C$

Thermal Characteristics

Parameter	Symbol	8N06G/D	Units
Thermal resistance , Junction to Case	$R_{th(j-c)}$	9.2	$^\circ C/W$
Maximum Power Dissipation	P_D	13.5	W

Electrical Characteristics ($T_c=25^\circ\text{C}$, unless otherwise noted)						
Parameter	Symbol	Test Conditions	Min	Typ	Max	Units
Off Characteristics						
Drain-Source Breakdown Voltage	BV_{DSS}	$V_{GS}=0V, I_D=250\mu A$	60	—	—	V
Zero Gate Voltage Drain Current	I_{DSS}	$V_{DS}=60V, V_{GS}=0V$	—	—	1	μA
Gate-Body Leakage Current, Forward	I_{GSSF}	$V_{GS}=20V, V_{DS}=0V$	—	—	100	nA
Gate-Body Leakage Current, Reverse	I_{GSSR}	$V_{GS}=-20V, V_{DS}=0V$	—	—	-100	nA
On Characteristics						
Gate-Source Threshold Voltage	$V_{GS(th)}$	$V_{DS}=V_{GS}, I_D=250\mu A$	1.0	—	2.5	V
Drain-Source On-State Resistance	$R_{DS(on)}$	$V_{GS}=10V, I_D=4A$	—	71	82	m Ω
	$R_{DS(on)}$	$V_{GS}=4.5V, I_D=4A$	—	92	107	
Dynamic Characteristics						
Input Capacitance	C_{iss}	$V_{DS}=30V, V_{GS}=0V,$ $f=1.0\text{MHz}$	—	505	—	pF
Output Capacitance	C_{oss}		—	30	—	pF
Reverse Transfer Capacitance	C_{rss}		—	20	—	pF
Switching Characteristics						
Turn-On Delay Time	$t_{d(on)}$	$V_{DD}=30V, I_D=5A,$ $R_g=3\Omega$ (Note3,4)	—	7.5	—	ns
Turn-On Rise Time	t_r		—	4.5	—	ns
Turn-Off Delay Time	$t_{d(off)}$		—	22.5	—	ns
Turn-Off Fall Time	t_f		—	9	—	ns
Total Gate Charge	Q_g	$V_{DS}=30V, I_D=5A,$ $V_{GS}=10V,$ (Note3,4)	—	11	—	nC
Gate-Source Charge	Q_{gs}		—	4	—	nC
Gate-Drain Charge	Q_{gd}		—	3.5	—	nC
Drain-Source Body Diode Characteristics and Maximum Ratings						
Continuous Diode Forward Current	I_S		—	—	8	A
Pulsed Diode Forward Current	I_{SM}		—	—	11	A
Diode Forward Voltage	V_{SD}	$I_S=7.5A, V_{GS}=0V$	—	—	1.2	V

Notes

1. Repetitive Rating: pulse width limited by maximum junction temperature .
2. $L=0.5\text{mH}, R_g=25\Omega, I_{AS}=10A, T_J=25^\circ\text{C}$.
3. $I_{SD} \leq I_D, dI/dt=100A/\mu s, V_{DD} \leq BV_{DSS}$, starting $T_J=25^\circ\text{C}$, Pulse width $\leq 300\mu s$; duty cycle $\leq 2\%$.
4. Repetitive rating; pulse width limited by maximum junction temperature.

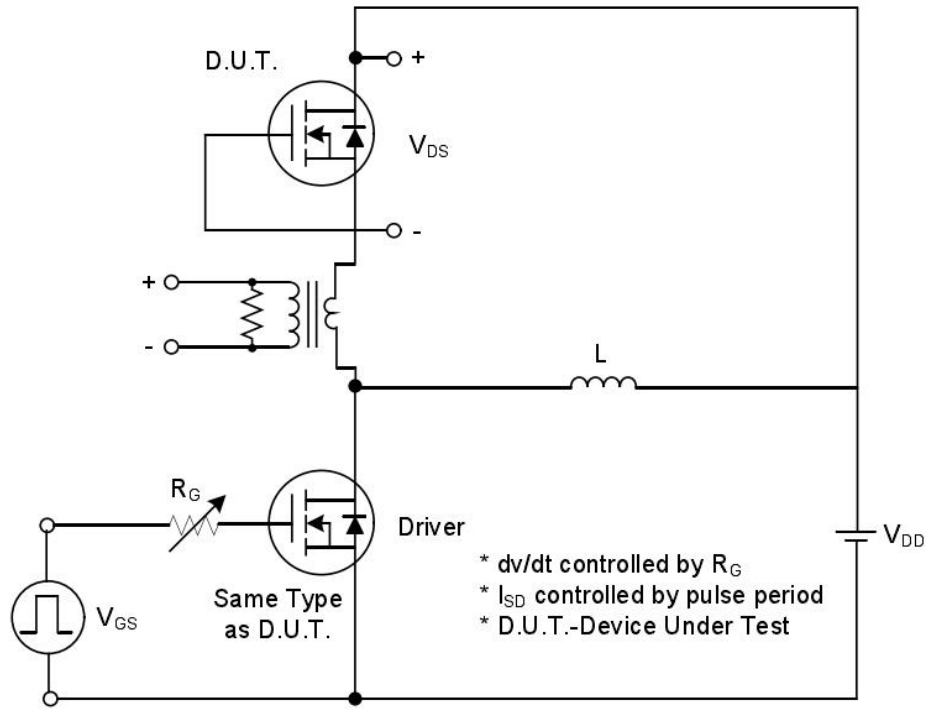

Fig. 1A Peak Diode Recovery dv/dt Test Circuit

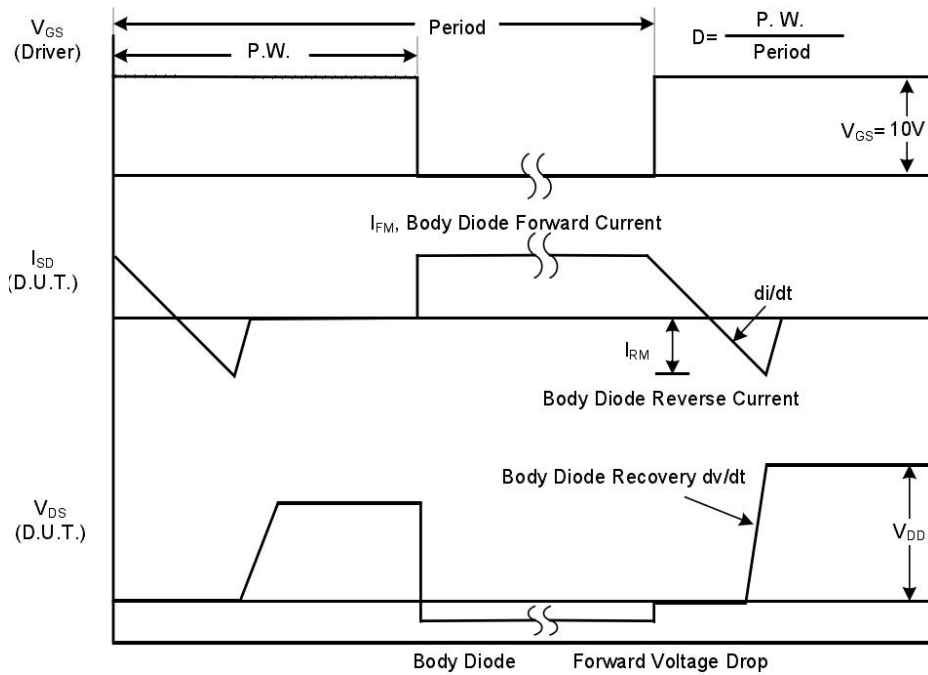

Fig. 1B Peak Diode Recovery dv/dt Waveforms

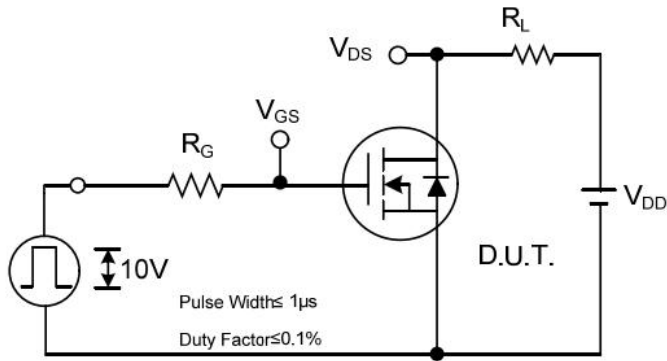

Fig. 2A Switching Test Circuit

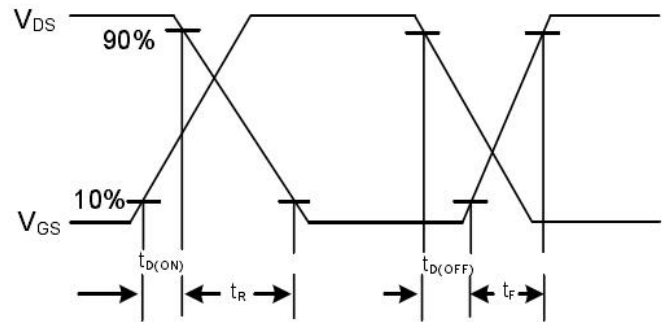

Fig. 2B Switching Waveforms

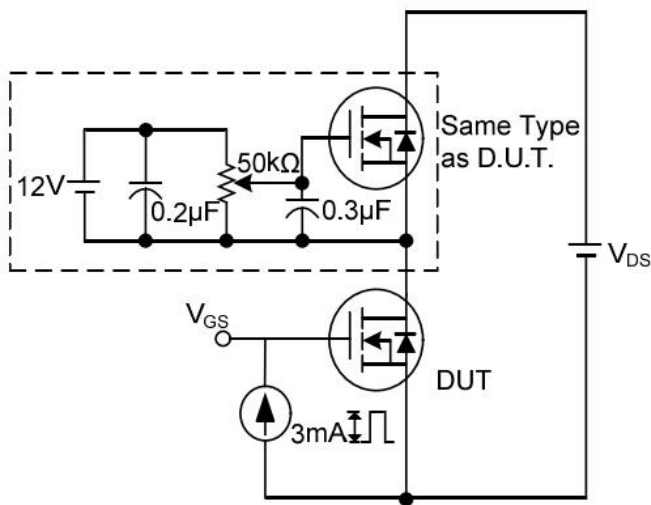

Fig. 3A Gate Charge Test Circuit

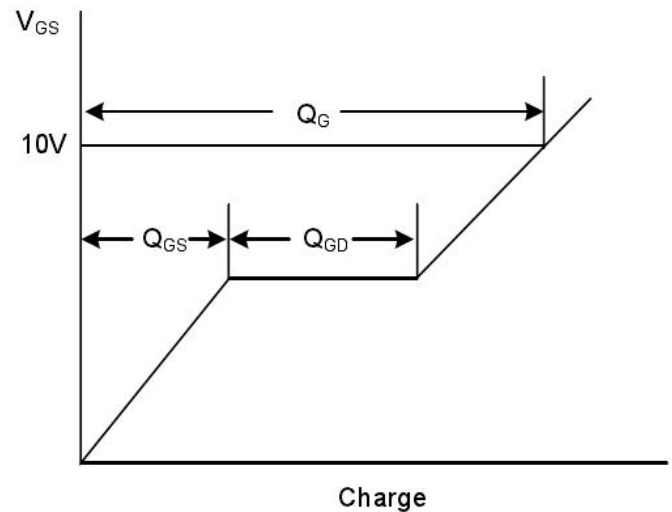

Fig. 3B Gate Charge Waveform

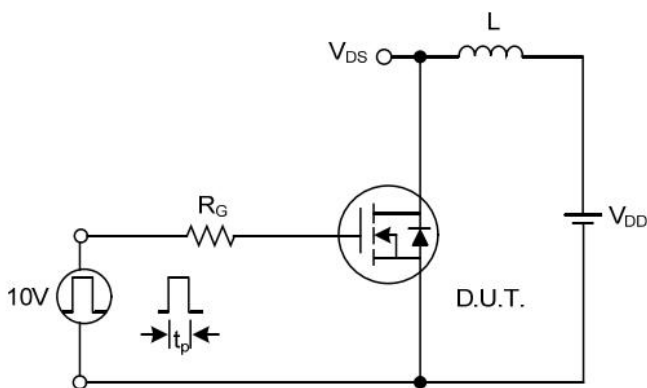

Fig. 4A Unclamped Inductive Switching Test Circuit

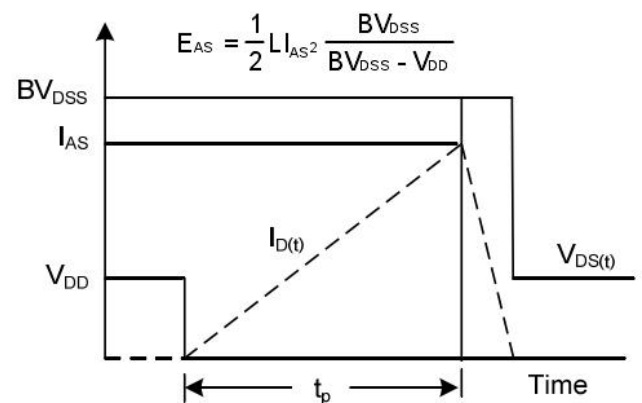
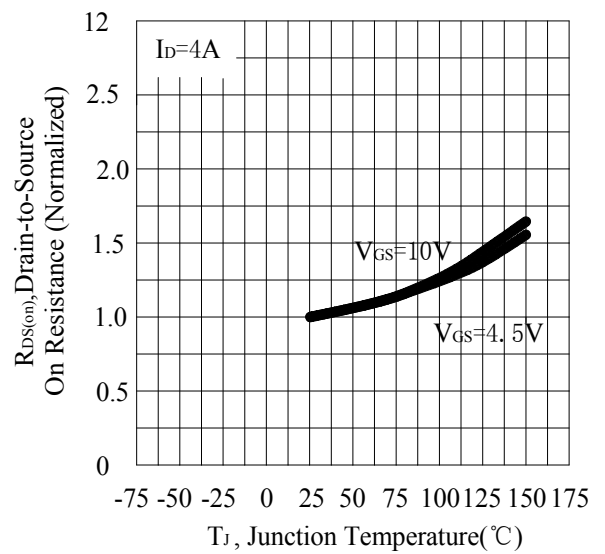
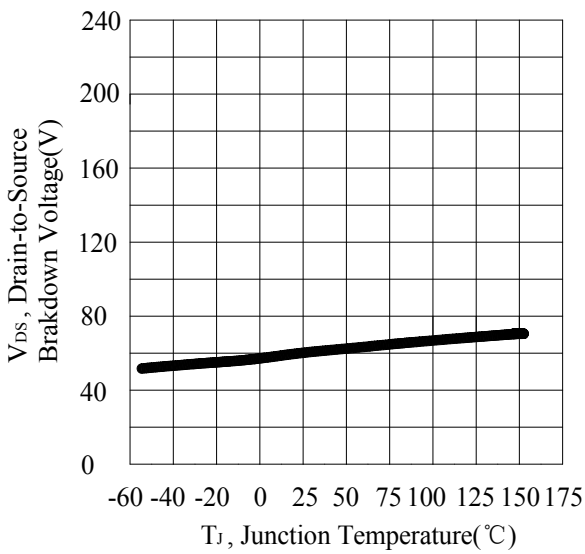
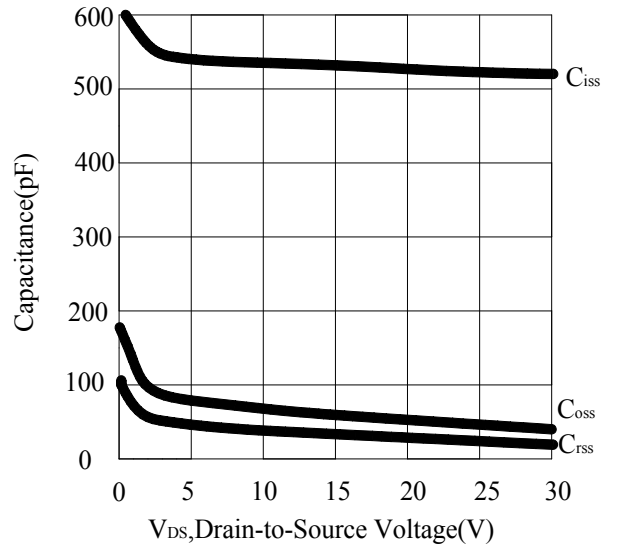
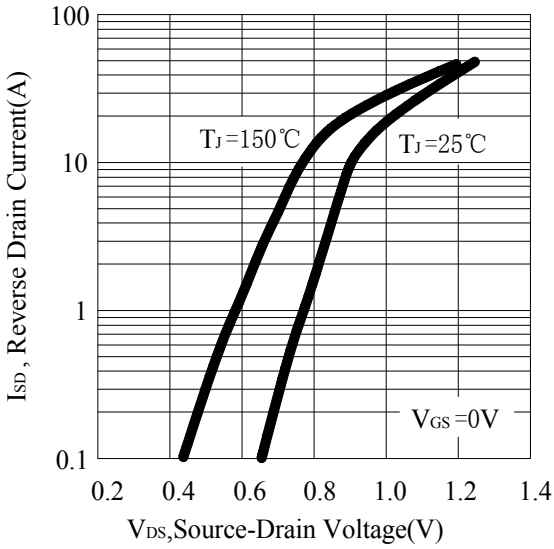
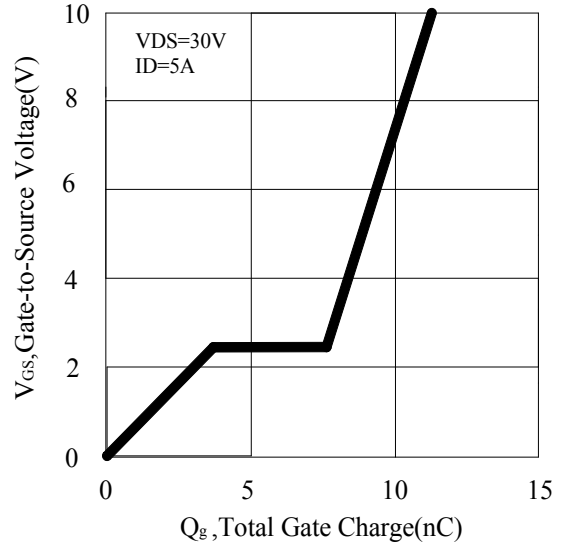
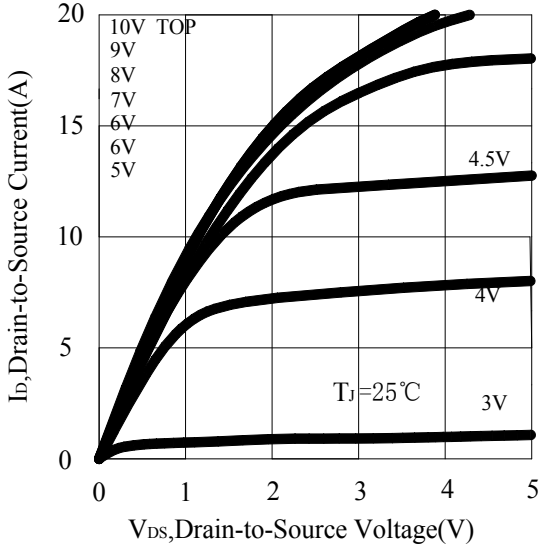
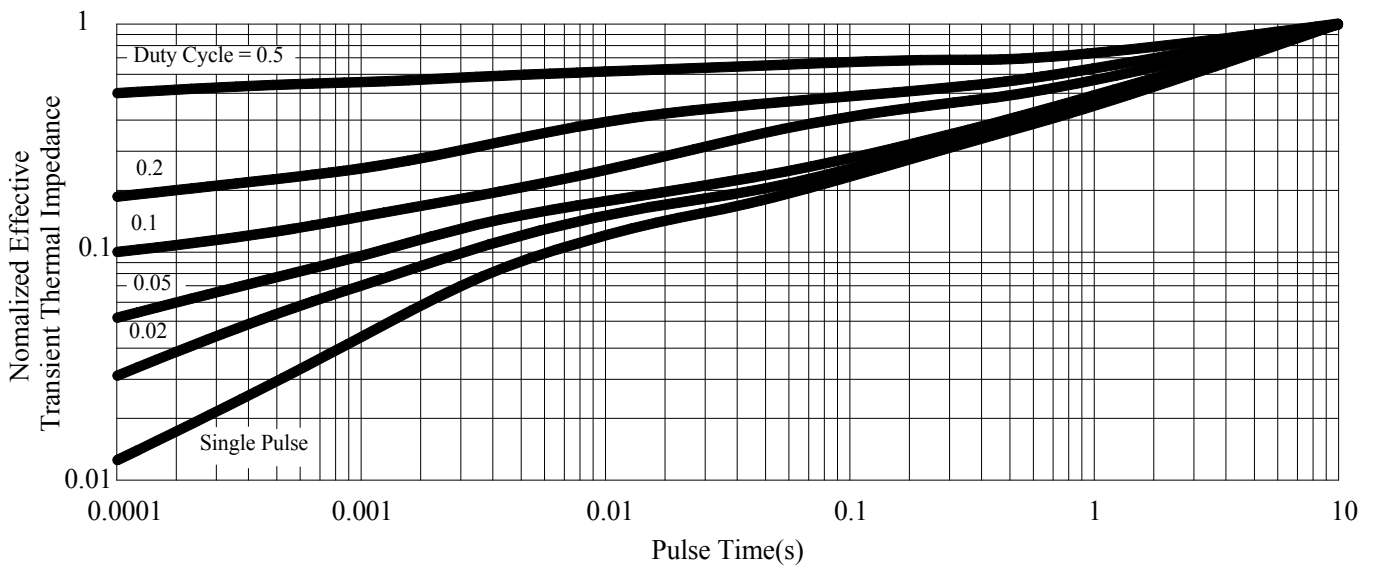
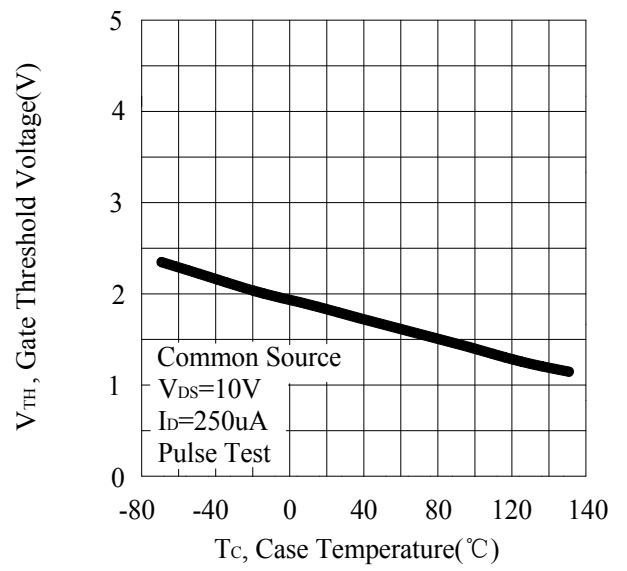
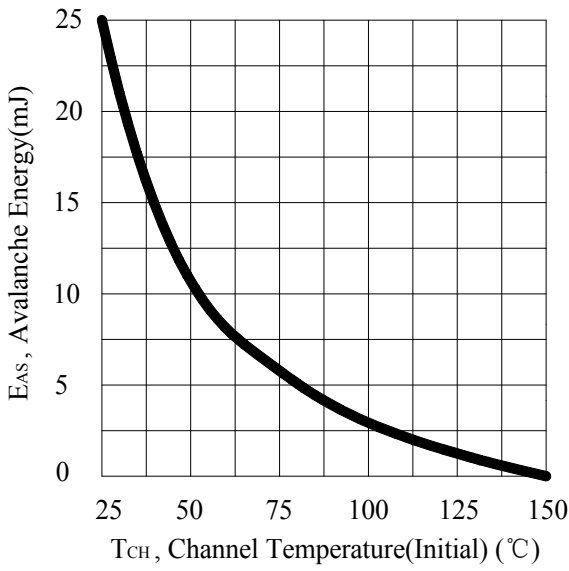
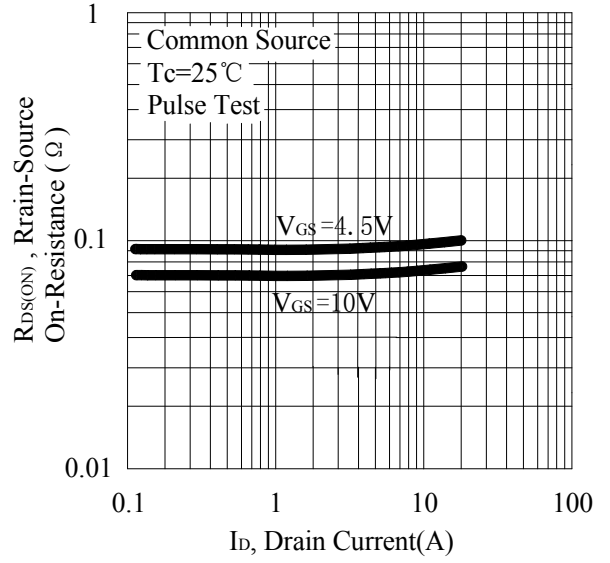
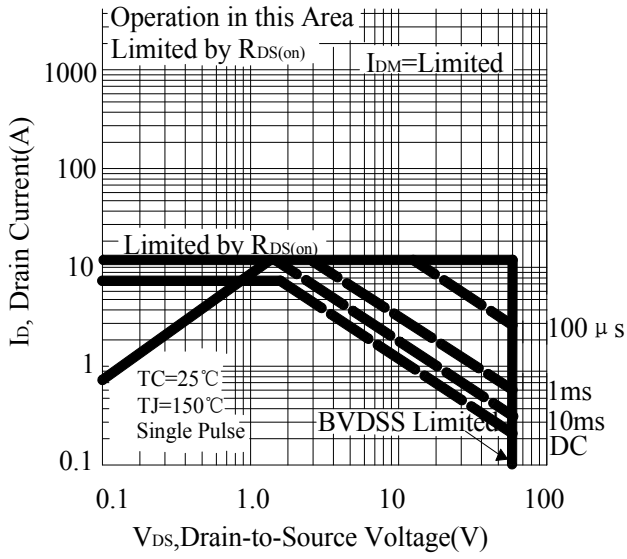

Fig. 4B Unclamped Inductive Switching Waveforms

RATING AND CHARACTERISTIC CURVES





PACKAGE OUTLINE DIMENSIONS

TO-252

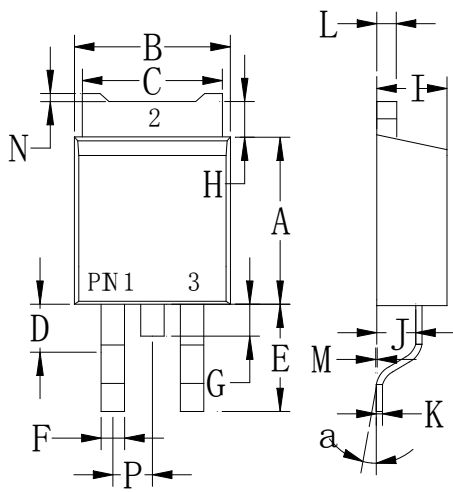

TO-252		
Dim	Min	Max
A	.230 (5.85)	.246 (6.25)
B	.250 (6.35)	.264 (6.75)
C	.207 (5.27)	.218 (5.54)
D	.037 (0.93)	.045 (1.14)
E	.106 (2.70)	.138 (3.50)
F	.028 (0.72)	.033 (0.84)
G	.024 (0.60)	.041 (1.05)
H	.028 (0.72)	.043 (1.10)
I	.085 (2.15)	.096 (2.45)
J	.037 (0.95)	.047 (1.20)
K	.018 (0.45)	.026 (0.65)
L	.018 (0.45)	.024 (0.60)
P	.081 (2.05)	.094 (2.40)
M	.000 (0.00)	.006 (0.15)
N	--	.008 (0.20)
a	0°	10°

Dimensions in inches and (millimeters)

TO-251

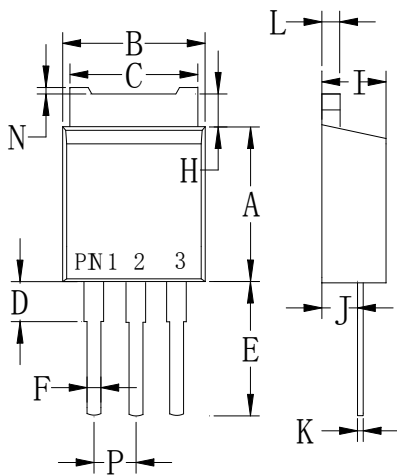

TO-251		
Dim	Min	Max
A	.230 (5.85)	.246 (6.25)
B	.250 (6.35)	.266 (6.75)
C	.207 (5.27)	.218 (5.54)
D	.037 (0.93)	.045 (1.14)
E	.173 (4.40)	.205 (5.20)
F	.028 (0.72)	.033 (0.84)
H	.028 (0.70)	.043 (1.10)
I	.085 (2.15)	.096 (2.45)
J	.037 (0.95)	.047 (1.20)
K	.018 (0.45)	.026 (0.65)
L	.018 (0.45)	.024 (0.60)
N	--	.008 (0.20)
P	.081 (2.05)	.094 (2.40)

Dimensions in inches and (millimeters)