

LM231A/LM231/LM331A/LM331 Precision Voltage-to-Frequency Converters

FEATURES

- Ensured Linearity 0.01% max
- Improved Performance in Existing Voltage-to-Frequency Conversion Applications
- Split or Single Supply Operation
- Operates on Single 5V Supply
- Pulse Output Compatible with All Logic Forms
- Excellent Temperature Stability: ± 50 ppm/ $^{\circ}$ C max
- Low Power Consumption: 15 mW Typical at 5V
- Wide Dynamic Range, 100 dB min at 10 kHz Full Scale Frequency
- Wide Range of Full Scale Frequency: 1 Hz to 100 kHz
- Low Cost

DESCRIPTION

The LM231/LM331 family of voltage-to-frequency converters are ideally suited for use in simple low-cost circuits for analog-to-digital conversion, precision frequency-to-voltage conversion, long-term integration, linear frequency modulation or demodulation, and many other functions. The output when used as a voltage-to-frequency converter is a pulse train at a frequency precisely proportional to the applied input voltage. Thus, it provides all the inherent advantages of the voltage-to-frequency conversion techniques, and is easy to apply in all standard voltage-to-frequency converter applications. Further, the LM231A/LM331A attain a new high level of accuracy versus temperature which could only be attained with expensive voltage-to-frequency modules. Additionally the LM231/331 are ideally suited for use in digital systems at low power supply voltages and can provide low-cost analog-to-digital conversion in microprocessor-controlled systems. And, the frequency from a battery powered voltage-to-frequency converter can be easily channeled through a simple photo isolator to provide isolation against high common mode levels.

The LM231/LM331 utilize a new temperature-compensated band-gap reference circuit, to provide excellent accuracy over the full operating temperature range, at power supplies as low as 4.0V. The precision timer circuit has low bias currents without degrading the quick response necessary for 100 kHz voltage-to-frequency conversion. And the output are capable of driving 3 TTL loads, or a high voltage output up to 40V, yet is short-circuit-proof against V_{CC} .

CONNECTION DIAGRAM

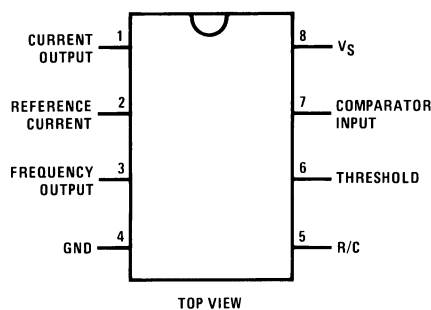

Figure 1. Plastic Dual-In-Line Package (PDIP)
See Package Number P (R-PDIP-T8)

Absolute Maximum Ratings⁽¹⁾⁽²⁾⁽³⁾

Supply Voltage, V_S	40V
Output Short Circuit to Ground	Continuous
Output Short Circuit to V_{CC}	Continuous
Input Voltage	-0.2V to $+V_S$
Package Dissipation at 25°C	1.25W ⁽⁴⁾
Lead Temperature (Soldering, 10 sec.)	
PDIP	260°C
ESD Susceptibility ⁽⁵⁾	500V

- (1) Absolute Maximum Ratings indicate limits beyond which damage to the device may occur. DC and AC electrical specifications do not apply when operating the device beyond its specified operating conditions.
- (2) All voltages are measured with respect to GND = 0V, unless otherwise noted.
- (3) If Military/Aerospace specified devices are required, please contact the TI Sales Office/Distributors for availability and specifications.
- (4) The absolute maximum junction temperature (T_{Jmax}) for this device is 150°C. The maximum allowable power dissipation is dictated by T_{Jmax} , the junction-to-ambient thermal resistance (θ_{JA}), and the ambient temperature T_A , and can be calculated using the formula $P_{Dmax} = (T_{Jmax} - T_A) / \theta_{JA}$. The values for maximum power dissipation will be reached only when the device is operated in a severe fault condition (e.g., when input or output pins are driven beyond the power supply voltages, or the power supply polarity is reversed). Obviously, such conditions should always be avoided.
- (5) Human body model, 100 pF discharged through a 1.5 kΩ resistor.

Operating Ratings⁽¹⁾

Operating Ambient Temperature	
LM231, LM231A	-25°C to +85°C
LM331, LM331A	0°C to +70°C
Supply Voltage, V_S	+4V to +40V

- (1) All voltages are measured with respect to GND = 0V, unless otherwise noted.

Package Thermal Resistance

Package	θ_{JA}
8-Lead PDIP	100°C/W

Electrical Characteristics

All specifications apply in the circuit of Figure 16, with $4.0V \leq V_S \leq 40V$, $T_A=25^\circ C$, unless otherwise specified.

Parameter	Conditions	Min	Typ	Max	Units
VFC Non-Linearity ⁽¹⁾	$4.5V \leq V_S \leq 20V$		±0.003	±0.01	% Full- Scale
	$T_{MIN} \leq T_A \leq T_{MAX}$		±0.006	±0.02	% Full- Scale
VFC Non-Linearity in Circuit of Figure 15	$V_S = 15V$, $f = 10 \text{ Hz to } 11 \text{ kHz}$		±0.024	±0.14	% Full- Scale
Conversion Accuracy Scale Factor (Gain)					
LM231, LM231A	$V_{IN} = -10V$, $R_S = 14 \text{ k}\Omega$	0.95	1.00	1.05	kHz/V
LM331, LM331A		0.90	1.00	1.10	kHz/V
Temperature Stability of Gain					
LM231/LM331	$T_{MIN} \leq T_A \leq T_{MAX}$, $4.5V \leq V_S \leq 20V$		±30	±150	ppm/°C
LM231A/LM331A			±20	±50	ppm/°C
Change of Gain with V_S	$4.5V \leq V_S \leq 10V$		0.01	0.1	%/V
	$10V \leq V_S \leq 40V$		0.006	0.06	%/V
Rated Full-Scale Frequency	$V_{IN} = -10V$	10.0			kHz
Gain Stability vs. Time (1000 Hours)	$T_{MIN} \leq T_A \leq T_{MAX}$		±0.02		% Full- Scale

- (1) Nonlinearity is defined as the deviation of f_{OUT} from $V_{IN} \times (10 \text{ kHz}/-10 V_{DC})$ when the circuit has been trimmed for zero error at 10 Hz and at 10 kHz, over the frequency range 1 Hz to 11 kHz. For the timing capacitor, C_T , use NPO ceramic, Teflon[®], or polystyrene.

Electrical Characteristics (continued)

All specifications apply in the circuit of Figure 16, with $4.0V \leq V_S \leq 40V$, $T_A=25^\circ C$, unless otherwise specified.

Parameter	Conditions	Min	Typ	Max	Units
Over Range (Beyond Full-Scale) Frequency	$V_{IN} = -11V$	10			%
INPUT COMPARATOR					
Offset Voltage			±3	±10	mV
LM231/LM331	$T_{MIN} \leq T_A \leq T_{MAX}$		±4	±14	mV
LM231A/LM331A	$T_{MIN} \leq T_A \leq T_{MAX}$		±3	±10	mV
Bias Current			-80	-300	nA
Offset Current			±8	±100	nA
Common-Mode Range	$T_{MIN} \leq T_A \leq T_{MAX}$	-0.2		$V_{CC}-2.0$	V
TIMER					
Timer Threshold Voltage, Pin 5		0.63	0.667	0.70	$\times V_S$
Input Bias Current, Pin 5	$V_S = 15V$				
All Devices	$0V \leq V_{PIN 5} \leq 9.9V$		±10	±100	nA
LM231/LM331	$V_{PIN 5} = 10V$		200	1000	nA
LM231A/LM331A	$V_{PIN 5} = 10V$		200	500	nA
$V_{SAT PIN 5}$ (Reset)	$I = 5 mA$		0.22	0.5	V
CURRENT SOURCE (Pin 1)					
Output Current					
LM231, LM231A	$R_S = 14 k\Omega, V_{PIN 1} = 0$	126	135	144	μA
LM331, LM331A		116	136	156	μA
Change with Voltage	$0V \leq V_{PIN 1} \leq 10V$		0.2	1.0	μA
Current Source OFF Leakage					
LM231, LM231A, LM331, LM331A			0.02	10.0	nA
All Devices	$T_A = T_{MAX}$		2.0	50.0	nA
Operating Range of Current (Typical)			(10 to 500)		μA
REFERENCE VOLTAGE (Pin 2)					
LM231, LM231A		1.76	1.89	2.02	V_{DC}
LM331, LM331A		1.70	1.89	2.08	V_{DC}
Stability vs. Temperature			±60		ppm/°C
Stability vs. Time, 1000 Hours			±0.1		%
LOGIC OUTPUT (Pin 3)					
V_{SAT}	$I = 5 mA$		0.15	0.50	V
	$I = 3.2 mA$ (2 TTL Loads), $T_{MIN} \leq T_A \leq T_{MAX}$		0.10	0.40	V
OFF Leakage			±0.05	1.0	μA
SUPPLY CURRENT					
LM231, LM231A	$V_S = 5V$	2.0	3.0	4.0	mA
	$V_S = 40V$	2.5	4.0	6.0	mA
LM331, LM331A	$V_S = 5V$	1.5	3.0	6.0	mA
	$V_S = 40V$	2.0	4.0	8.0	mA

FUNCTIONAL BLOCK DIAGRAM

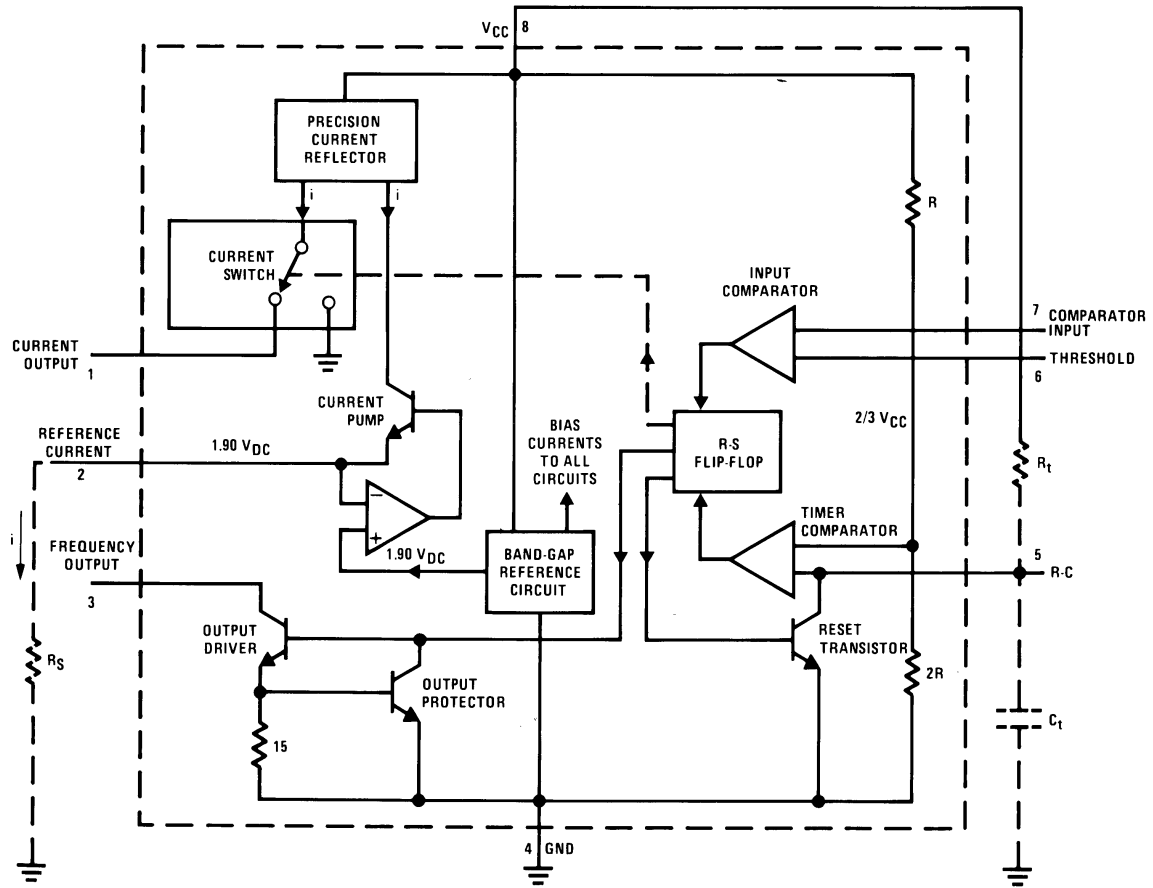

Pin numbers apply to 8-pin packages only.

TYPICAL PERFORMANCE CHARACTERISTICS

(All electrical characteristics apply for the circuit of Figure 16, unless otherwise noted.)

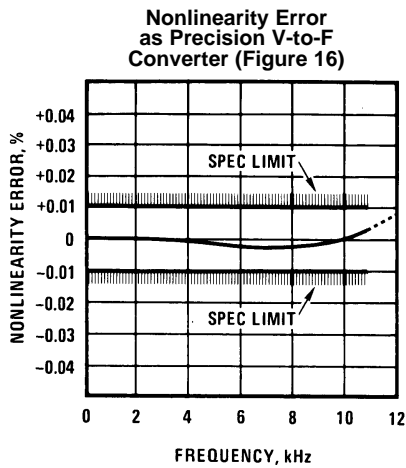

Figure 2.

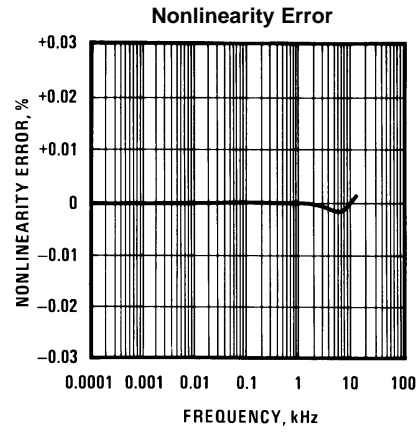

Figure 3.

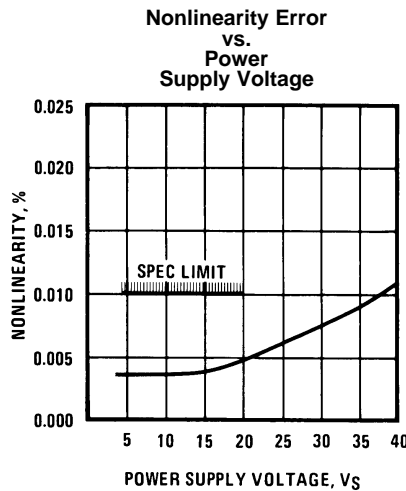

Figure 4.

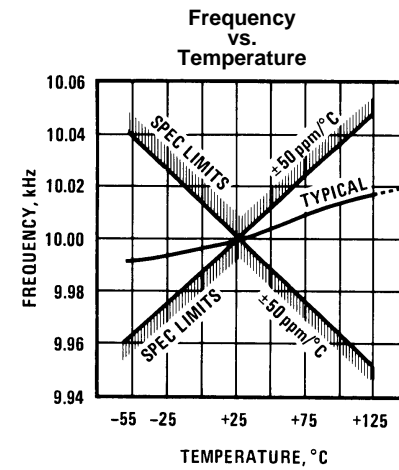

Figure 5.

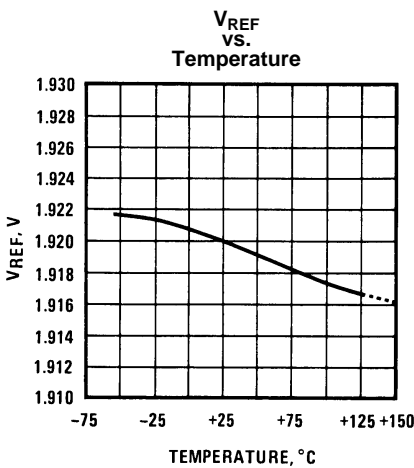

Figure 6.

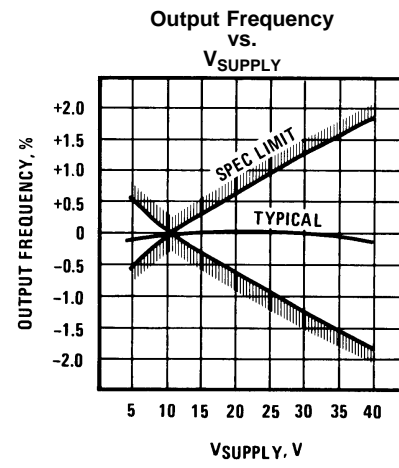

Figure 7.

TYPICAL PERFORMANCE CHARACTERISTICS (continued)

(All electrical characteristics apply for the circuit of Figure 16, unless otherwise noted.)

100 kHz Nonlinearity Error (Figure 17)

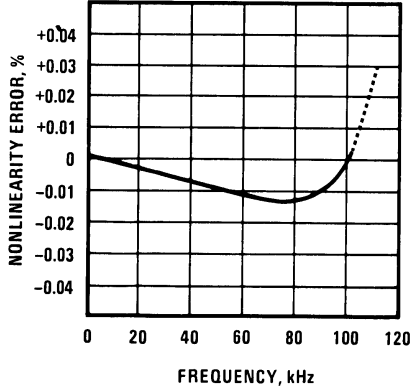

Figure 8.

Nonlinearity Error (Figure 15)

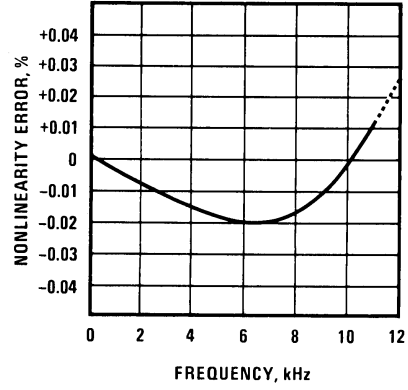

Figure 9.

Input Current (Pins 6,7) vs. Temperature

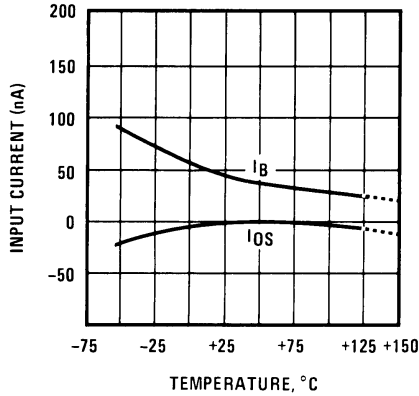

Figure 10.

Power Drain vs. V_{SUPPLY}

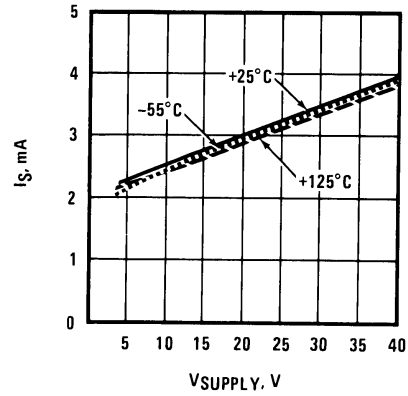

Figure 11.

Output Saturation Voltage vs. I_{OUT} (Pin 3)

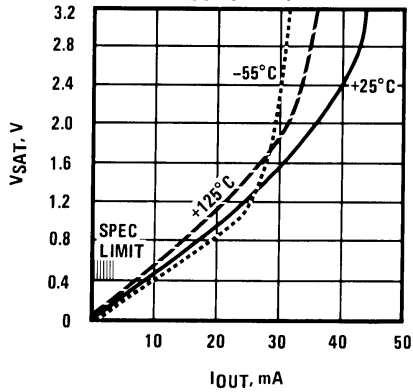

Figure 12.

Nonlinearity Error, Precision F-to-V Converter (Figure 19)

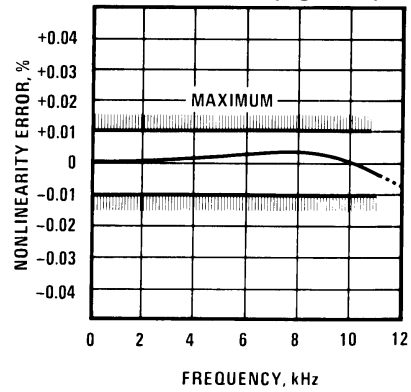

Figure 13.

APPLICATIONS INFORMATION

PRINCIPLES OF OPERATION

The LM231/331 are monolithic circuits designed for accuracy and versatile operation when applied as voltage-to-frequency (V-to-F) converters or as frequency-to-voltage (F-to-V) converters. A simplified block diagram of the LM231/331 is shown in Figure 14 and consists of a switched current source, input comparator, and 1-shot timer.

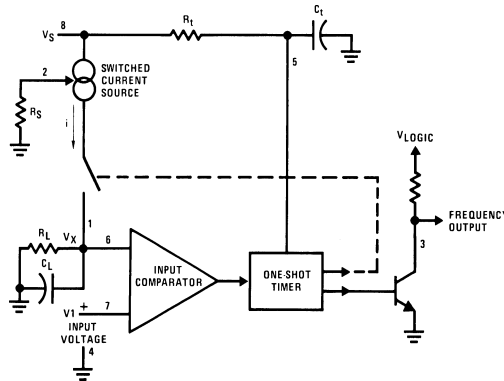

Figure 14. Simplified Block Diagram of Stand-Alone Voltage-to-Frequency Converter and External Components

Simplified Voltage-to-Frequency Converter

The operation of these blocks is best understood by going through the operating cycle of the basic V-to-F converter, Figure 14, which consists of the simplified block diagram of the LM231/331 and the various resistors and capacitors connected to it.

The voltage comparator compares a positive input voltage, V_1 , at pin 7 to the voltage, V_x , at pin 6. If V_1 is greater, the comparator will trigger the 1-shot timer. The output of the timer will turn ON both the frequency output transistor and the switched current source for a period $t=1.1 R_T C_T$. During this period, the current i will flow out of the switched current source and provide a fixed amount of charge, $Q = i \times t$, into the capacitor, C_L . This will normally charge V_x up to a higher level than V_1 . At the end of the timing period, the current i will turn OFF, and the timer will reset itself.

Now there is no current flowing from pin 1, and the capacitor C_L will be gradually discharged by R_L until V_x falls to the level of V_1 . Then the comparator will trigger the timer and start another cycle.

The current flowing into C_L is exactly $I_{AVE} = i \times (1.1 \times R_T C_T) \times f$, and the current flowing out of C_L is exactly $V_x / R_L \approx V_{IN} / R_L$. If V_{IN} is doubled, the frequency will double to maintain this balance. Even a simple V-to-F converter can provide a frequency precisely proportional to its input voltage over a wide range of frequencies.

Detail of Operation, Functional Block Diagram

The block diagram (FUNCTIONAL BLOCK DIAGRAM) shows a band gap reference which provides a stable 1.9 V_{DC} output. This 1.9 V_{DC} is well regulated over a V_S range of 3.9V to 40V. It also has a flat, low temperature coefficient, and typically changes less than 1/2% over a 100°C temperature change.

The current pump circuit forces the voltage at pin 2 to be at 1.9V, and causes a current $i=1.90V/R_S$ to flow. For $R_S=14k$, $i=135 \mu A$. The precision current reflector provides a current equal to i to the current switch. The current switch switches the current to pin 1 or to ground, depending upon the state of the R_S flip-flop.

The timing function consists of an R_S flip-flop and a timer comparator connected to the external $R_T C_T$ network. When the input comparator detects a voltage at pin 7 higher than pin 6, it sets the R_S flip-flop which turns ON the current switch and the output driver transistor. When the voltage at pin 5 rises to $2/3 V_{CC}$, the timer comparator causes the R_S flip-flop to reset. The reset transistor is then turned ON and the current switch is turned OFF.

However, if the input comparator still detects pin 7 higher than pin 6 when pin 5 crosses $\frac{2}{3} V_{CC}$, the flip-flop will not be reset, and the current at pin 1 will continue to flow, trying to make the voltage at pin 6 higher than pin 7. This condition will usually apply under start-up conditions or in the case of an overload voltage at signal input. During this sort of overload the output frequency will be 0. As soon as the signal is restored to the working range, the output frequency will be resumed.

The output driver transistor acts to saturate pin 3 with an ON resistance of about 50Ω. In case of over voltage, the output current is actively limited to less than 50 mA.

The voltage at pin 2 is regulated at 1.90 V_{DC} for all values of *i* between 10 μA to 500 μA. It can be used as a voltage reference for other components, but care must be taken to ensure that current is not taken from it which could reduce the accuracy of the converter.

Basic Voltage-to-Frequency Converter (Figure 15)

The simple stand-alone V-to-F converter shown in Figure 15 includes all the basic circuitry of Figure 14 plus a few components for improved performance.

A resistor, R_{IN}=100 kΩ ±10%, has been added in the path to pin 7, so that the bias current at pin 7 (-80 nA typical) will cancel the effect of the bias current at pin 6 and help provide minimum frequency offset.

The resistance R_S at pin 2 is made up of a 12 kΩ fixed resistor plus a 5 kΩ (cermet, preferably) gain adjust rheostat. The function of this adjustment is to trim out the gain tolerance of the LM231/331, and the tolerance of R_T, R_L and C_T.

For best results, all the components should be stable low-temperature-coefficient components, such as metal-film resistors. The capacitor should have low dielectric absorption; depending on the temperature characteristics desired, NPO ceramic, polystyrene, Teflon or polypropylene are best suited.

A capacitor C_{IN} is added from pin 7 to ground to act as a filter for V_{IN}. A value of 0.01 μF to 0.1 μF will be adequate in most cases; however, in cases where better filtering is required, a 1 μF capacitor can be used. When the RC time constants are matched at pin 6 and pin 7, a voltage step at V_{IN} will cause a step change in f_{OUT}. If C_{IN} is much less than C_L, a step at V_{IN} may cause f_{OUT} to stop momentarily.

A 47Ω resistor, in series with the 1 μF C_L, provides hysteresis, which helps the input comparator provide the excellent linearity.

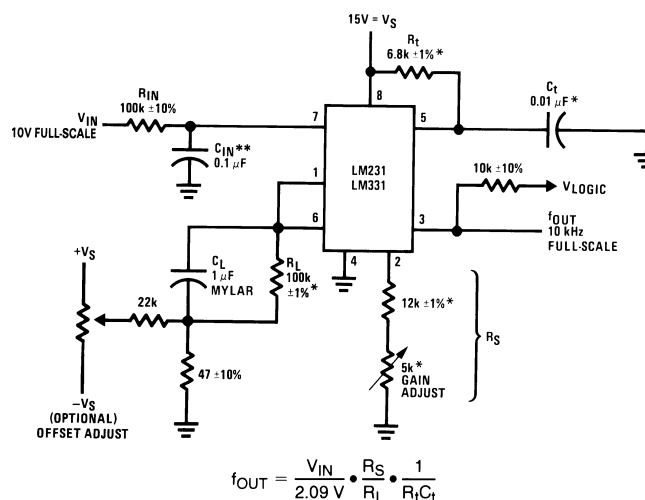

*Use stable components with low temperature coefficients. See APPLICATIONS INFORMATION.

**0.1μF or 1μF, See PRINCIPLES OF OPERATION.

Figure 15. Simple Stand-Alone V-to-F Converter with ±0.03% Typical Linearity (f = 10 Hz to 11 kHz)

Details of Operation: Precision V-To-F Converter (Figure 16)

In this circuit, integration is performed by using a conventional operational amplifier and feedback capacitor, C_F . When the integrator's output crosses the nominal threshold level at pin 6 of the LM231/331, the timing cycle is initiated.

The average current fed into the op-amp's summing point (pin 2) is $i \times (1.1 R_t C_t) \times f$ which is perfectly balanced with $-V_{IN}/R_{IN}$. In this circuit, the voltage offset of the LM231/331 input comparator does not affect the offset or accuracy of the V-to-F converter as it does in the stand-alone V-to-F converter; nor does the LM231/331 bias current or offset current. Instead, the offset voltage and offset current of the operational amplifier are the only limits on how small the signal can be accurately converted. Since op-amps with voltage offset well below 1 mV and offset currents well below 2 nA are available at low cost, this circuit is recommended for best accuracy for small signals. This circuit also responds immediately to any change of input signal (which a stand-alone circuit does not) so that the output frequency will be an accurate representation of V_{IN} , as quickly as 2 output pulses' spacing can be measured.

In the precision mode, excellent linearity is obtained because the current source (pin 1) is always at ground potential and that voltage does not vary with V_{IN} or f_{OUT} . (In the stand-alone V-to-F converter, a major cause of non-linearity is the output impedance at pin 1 which causes i to change as a function of V_{IN}).

The circuit of Figure 17 operates in the same way as Figure 16, but with the necessary changes for high speed operation.

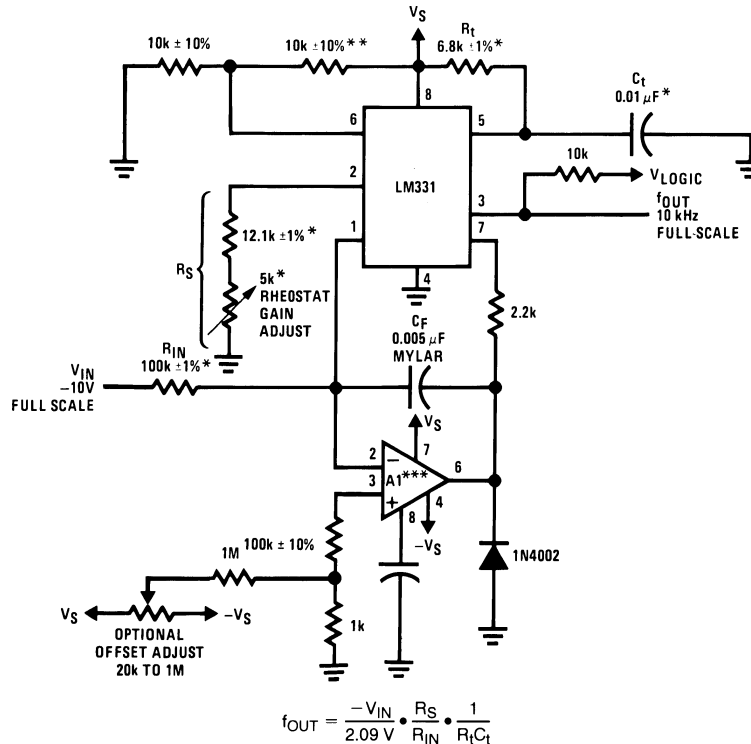

*Use stable components with low temperature coefficients. See APPLICATIONS INFORMATION.

**This resistor can be 5 kΩ or 10 kΩ for $V_S=8V$ to $22V$, but must be 10 kΩ for $V_S=4.5V$ to $8V$.

***Use low offset voltage and low offset current op-amps for A1: recommended type LF411A

Figure 16. Standard Test Circuit and Applications Circuit, Precision Voltage-to-Frequency Converter

DETAILS OF OPERATION: F-to-V CONVERTERS (Figure 18 and Figure 19)

In these applications, a pulse input at f_{IN} is differentiated by a C-R network and the negative-going edge at pin 6 causes the input comparator to trigger the timer circuit. Just as with a V-to-F converter, the average current flowing out of pin 1 is $I_{AVERAGE} = i \times (1.1 R_t C_t) \times f$.

In the simple circuit of Figure 18, this current is filtered in the network $R_L = 100\text{ k}\Omega$ and $1\text{ }\mu\text{F}$. The ripple will be less than 10 mV peak, but the response will be slow, with a 0.1 second time constant, and settling of 0.7 second to 0.1% accuracy.

In the precision circuit, an operational amplifier provides a buffered output and also acts as a 2-pole filter. The ripple will be less than 5 mV peak for all frequencies above 1 kHz , and the response time will be much quicker than in Figure 18. However, for input frequencies below 200 Hz , this circuit will have worse ripple than Figure 18. The engineering of the filter time-constants to get adequate response and small enough ripple simply requires a study of the compromises to be made. Inherently, V-to-F converter response can be fast, but F-to-V response can not.

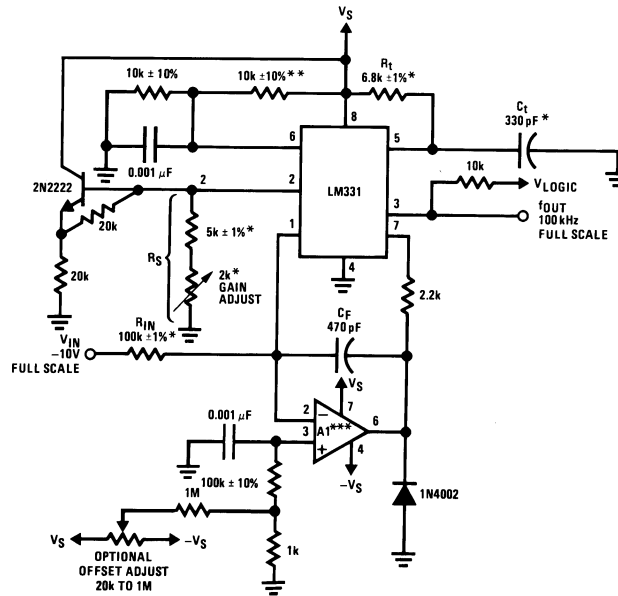

*Use stable components with low temperature coefficients.
See APPLICATIONS INFORMATION.

**This resistor can be $5\text{ k}\Omega$ or $10\text{ k}\Omega$ for $V_S=8\text{V}$ to 22V , but must be $10\text{ k}\Omega$ for $V_S=4.5\text{V}$ to 8V .

***Use low offset voltage and low offset current op-amps for A1: recommended types LF411A or LF356.

**Figure 17. Precision Voltage-to-Frequency Converter,
100 kHz Full-Scale, $\pm 0.03\%$ Non-Linearity**

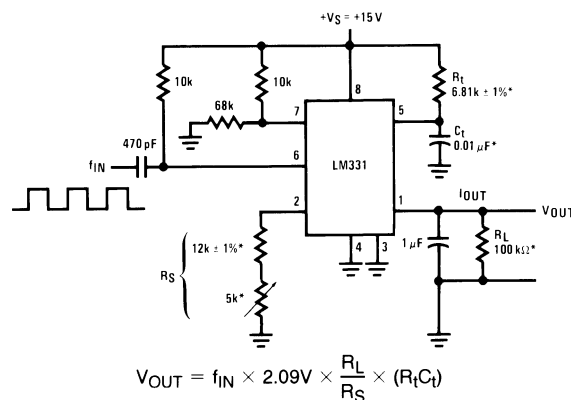

*Use stable components with low temperature coefficients.

**Figure 18. Simple Frequency-to-Voltage Converter,
10 kHz Full-Scale, $\pm 0.06\%$ Non-Linearity**

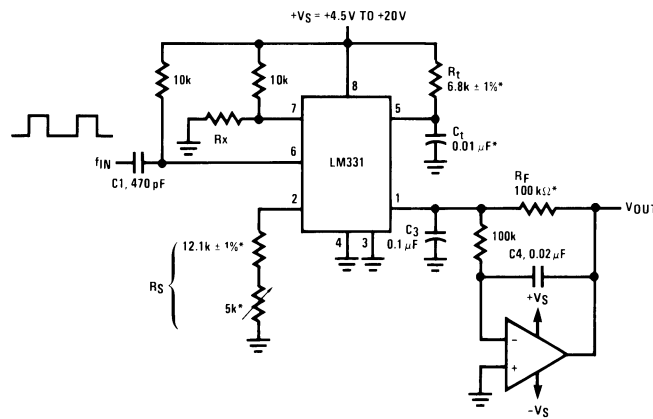

$$V_{OUT} = -f_{IN} \times 2.09V \times \frac{R_F}{R_S} \times (R_T C_T)$$

$$\text{SELECT } R_x = \frac{(V_S - 2V)}{0.2 \text{ mA}}$$

*Use stable components with low temperature coefficients.

Figure 19. Precision Frequency-to-Voltage Converter, 10 kHz Full-Scale with 2-Pole Filter, ±0.01% Non-Linearity Maximum

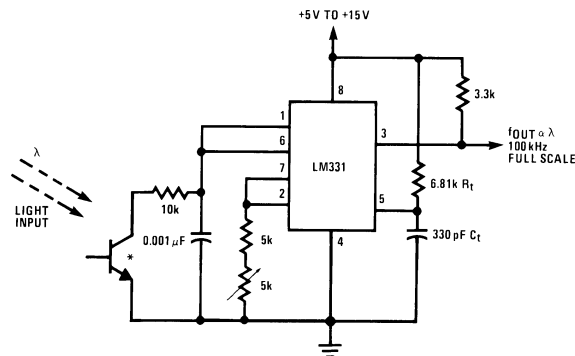

*L14F-1, L14G-1 or L14H-1, photo transistor (General Electric Co.) or similar

Figure 20. Light Intensity to Frequency Converter

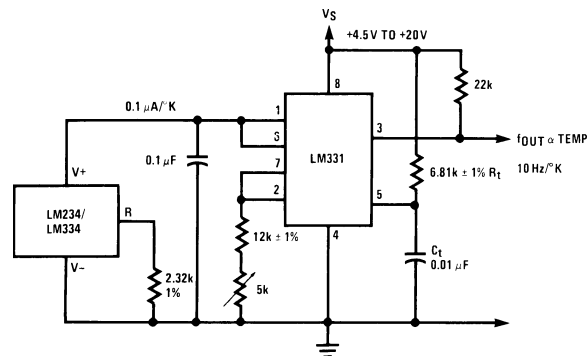

Figure 21. Temperature to Frequency Converter

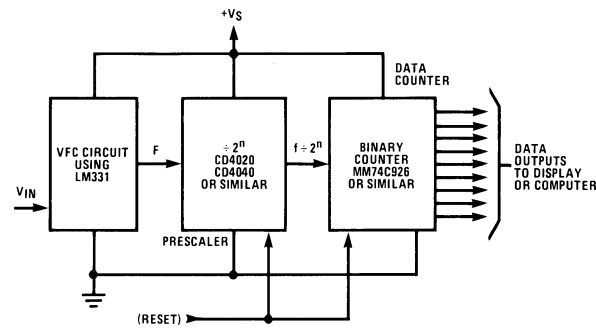

Figure 22. Long-Term Digital Integrator Using VFC

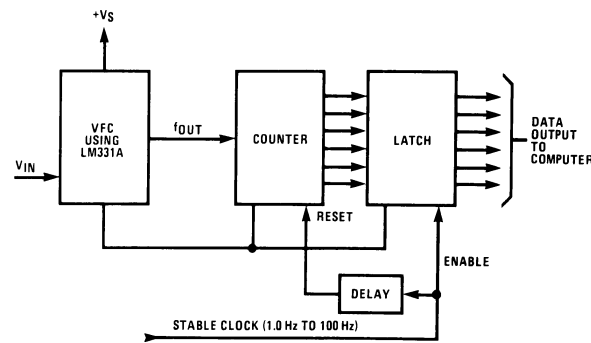

Figure 23. Basic Analog-to-Digital Converter Using Voltage-to-Frequency Converter

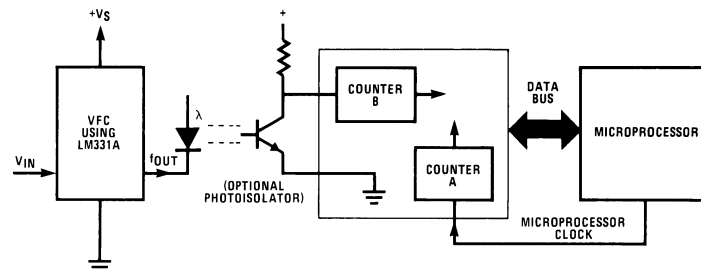

Figure 24. Analog-to-Digital Converter with Microprocessor

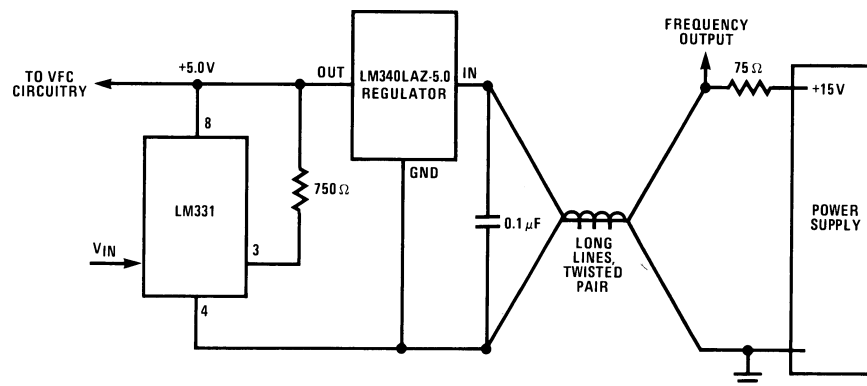

Figure 25. Remote Voltage-to-Frequency Converter with 2-Wire Transmitter and Receiver

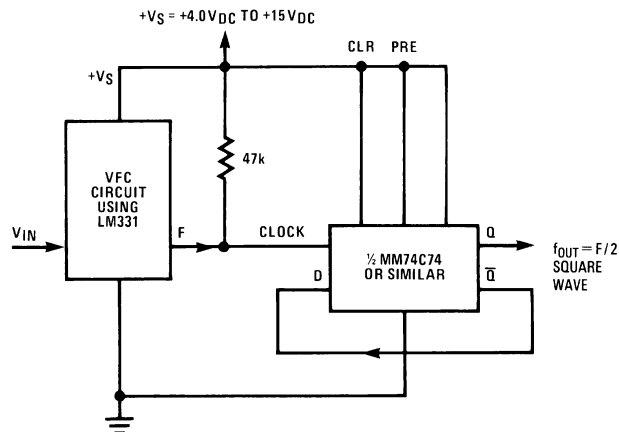

Figure 26. Voltage-to-Frequency Converter with Square-Wave Output Using $\div 2$ Flip-Flop

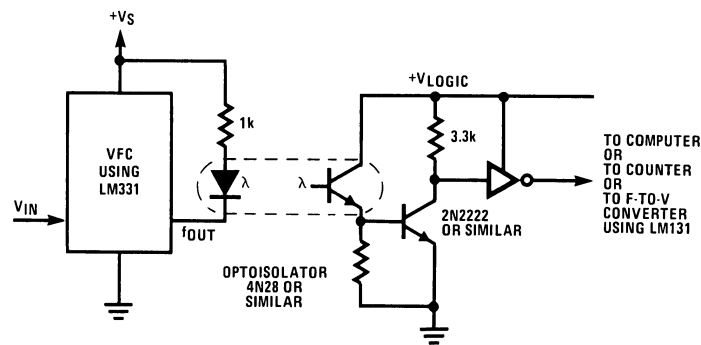

Figure 27. Voltage-to-Frequency Converter with Isolators

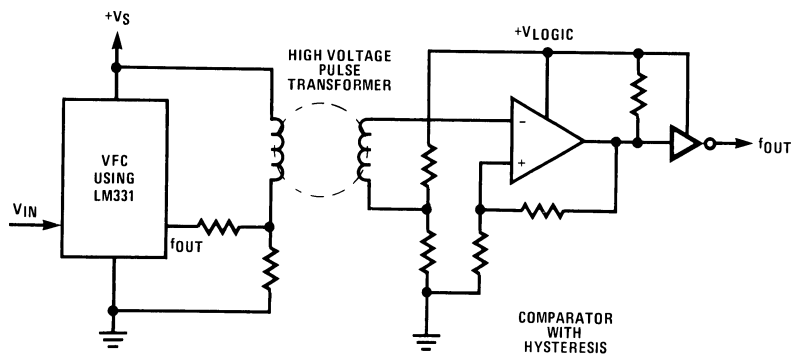

Figure 28. Voltage-to-Frequency Converter with Isolators

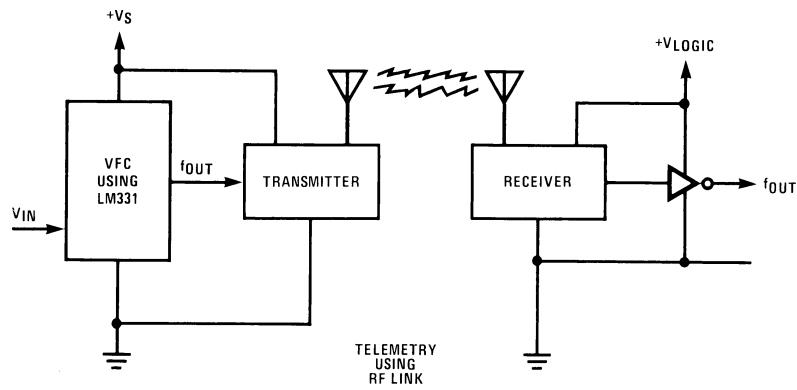

Figure 29. Voltage-to-Frequency Converter with Isolators

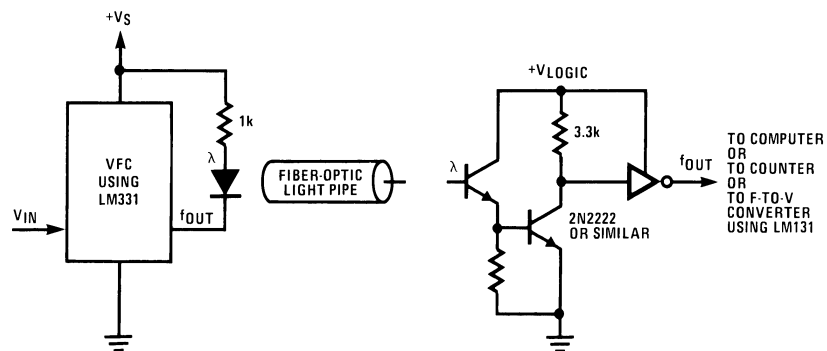

Figure 30. Voltage-to-Frequency Converter with Isolators

Schematic Diagram

