

## N-channel MOSFET

### FEATURES

- Low on-resistance
- Fast switching speed
- Low voltage drive makes this device ideal for portable equipment
- Easily designed drive circuits
- Easy to parallel

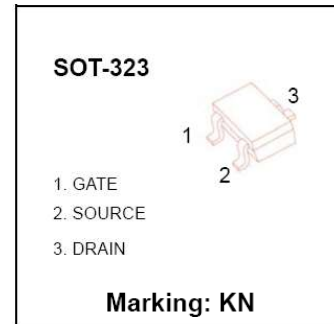

### MOSFET MAXIMUM RATINGS ( $T_a = 25^\circ\text{C}$ unless otherwise noted)

Symbol	Parameter	Value	Units
$V_{DS}$	Drain-Source voltage	30	V
$V_{GS}$	Gate-Source Voltage	$\pm 20$	V
$I_D$	Continuous Drain Current	0.1	A
$P_D$	Power Dissipation	0.2	W
$T_J$	Junction Temperature	150	$^\circ\text{C}$
$T_{stg}$	Storage Temperature	-55-150	$^\circ\text{C}$
$R_{\theta JA}$	Thermal Resistance from Junction to Ambient	625	$^\circ\text{C}/\text{W}$

### Equivalent circuit

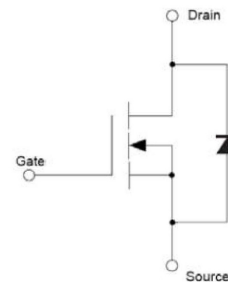

### MOSFET ELECTRICAL CHARACTERISTICS ( $T_a = 25^\circ\text{C}$ unless otherwise noted)

Parameter	Symbol	Test Condition	Min	Typ	Max	Units
<b>Off Characteristics</b>						
Drain-Source Breakdown Voltage	$V_{(BR)DSS}$	$V_{GS} = 0V, I_D = 10\mu\text{A}$	30			V
Zero Gate Voltage Drain Current	$I_{DSS}$	$V_{DS} = 30V, V_{GS} = 0V$			0.2	$\mu\text{A}$
Gate -Source leakage current	$I_{GSS}$	$V_{GS} = \pm 20V, V_{DS} = 0V$			$\pm 500$	nA
Gate Threshold Voltage	$V_{GS(th)}$	$V_{DS} = 3V, I_D = 100\mu\text{A}$	0.8		1.5	V
Drain-Source On-Resistance	$R_{DS(on)}$	$V_{GS} = 4V, I_D = 10\text{mA}$			8	$\Omega$
		$V_{GS} = 2.5V, I_D = 1\text{mA}$			13	$\Omega$
Forward Transconductance	$g_{FS}$	$V_{DS} = 3V, I_D = 10\text{mA}$	20			mS
<b>Dynamic Characteristics*</b>						
Input Capacitance	$C_{iss}$	$V_{DS} = 5V, V_{GS} = 0V, f = 1\text{MHz}$		13		pF
Output Capacitance	$C_{oss}$			9		pF
Reverse Transfer Capacitance	$C_{rss}$			4		pF
<b>Switching Characteristics*</b>						
Turn-On Delay Time	$t_{d(on)}$	$V_{GS} = 5V, V_{DD} = 5V, I_D = 10\text{mA}, R_g = 10\Omega, R_L = 500\Omega$		15		ns
Rise Time	$t_r$			35		ns
Turn-Off Delay Time	$t_{d(off)}$			80		ns
Fall Time	$t_f$			80		ns

