

Document Title

A8105 Data Sheet, 2.4GHz FSK/GFSK SOC

Revision History

<u>Rev. No.</u>	<u>History</u>	<u>Issue Date</u>	<u>Remark</u>
0.0	Initial issue.	June, 2012	Objective
0.1	Add RF register	Sep, 2012	Objective
0.2	Modify RF register	Sep, 2013	Preliminary
0.3	Remove RCADC	Oct., 2013	Preliminary
0.4	Revise Order information	Jan., 2014	Preliminary
0.5	Add 32Kbytes Flash version and related information.	Apr., 2014	Preliminary
0.6	Add die form and QFN48L in order information. Add reset timing of stable power and RESETN pin Add P2 registers for extra 4 GPIO for 32KB flash version	Sep., 2014	Preliminary

AMICCOM CONFIDENTIAL

Important Notice:

AMICCOM reserves the right to make changes to its products or to discontinue any integrated circuit product or service without notice. AMICCOM integrated circuit products are not designed, intended, authorized, or warranted to be suitable for use in life-support applications, devices or systems or other critical applications. Use of AMICCOM products in such applications is understood to be fully at the risk of the customer.

Table of Contents

1. General Description	1
2. Typical Applications	1
3. Feature	1
4. Pin Configurations	3
5. Pin Description (I: input; O: output, I/O: input or output)	5
6. Chip Block Diagram	7
7. Absolute Maximum Ratings	8
8. Electrical Specification	9
9. SFR & RFR(Radio Frequency Register)	11
9.1 SFR Overview	11
9.2 RFR Overview	13
9.2.1 Mode Register (Address: 0x800h)	17
9.2.2 Mode Control Register 1 (Address: 0x801h)	17
9.2.3 Mode Control Register 2 (Address: 0x802h)	18
9.2.4 Calibration Control Register (Address: 0x803h)	18
9.2.5 FIFO Register I (Address: 0x804h)	19
9.2.6 FIFO Register II (Address: 0x805h)	19
9.2.7 RC OSC Register I (Address: 0x806h)	19
9.2.8 RC OSC Register II (Address: 0x807h)	19
9.2.9 RC OSC Register III (Address: 0x808h)	19
9.2.10 RC OSC Register IV (Address: 0x809h)	20
9.2.11 RC OSC Register V (Address: 0x80Ah)	20
9.2.12 RC OSC Register VI (Address: 0x80Bh)	20
9.2.13 RC OSC Register VII (Address: 0x80Ch)	21
9.2.14 RC OSC Register VIII (Address: 0x80Dh)	21
9.2.15 CKO Pin Control Register (Address: 0x80Eh)	21
9.2.16 GIO1 Pin Control Register I (Address: 0x80Fh)	21
9.2.17 GIO2 Pin Control Register II (Address: 0x810h)	22
9.2.18 Clock Register (Address: 0x811h)	23
9.2.19 Data Rate Register (Address: 0x812h)	23
9.2.20 PLL Register I (Address: 0x813h)	23
9.2.21 PLL Register II (Address: 0x814h)	23
9.2.22 PLL Register III (Address: 0x815h)	24
9.2.23 PLL Register IV (Address: 0x816h)	24
9.2.24 PLL Register V (Address: 0x817h)	24
9.2.25 TX Register I (Address: 0x818h)	24
9.2.26 TX Register II (Address: 0x819h)	25
9.2.27 Delay Register I (Address: 0x81Ah)	25
9.2.28 Delay Register II (Address: 0x81Bh)	25
9.2.29 RX Register (Address: 0x81Ch)	25
9.2.30 RX Gain Register I (Address: 0x81Dh)	26
9.2.31 RX Gain Register II (Address: 0x81Eh)	26
9.2.32 RX Gain Register III (Address: 0x81Fh)	27
9.2.33 RX Gain Register IV (Address: 0x820h)	27
9.2.34 RSSI Threshold Register (Address: 0x821h)	27
9.2.35 ADC Control Register (Address: 0x822h)	28
9.2.36 Code Register I (Address: 0x823h)	28
9.2.37 Code Register II (Address: 0x824h)	28
9.2.38 Code Register III (Address: 0x825h)	29
9.2.39 IF Calibration Register I (Address: 0x826h)	29
9.2.40 IF Calibration Register II (Address: 0x827h)	29
9.2.41 VCO current Calibration Register (Address: 0x828h)	30
9.2.42 VCO Single band Calibration Register I (Address: 0x829h)	30
9.2.43 VCO Single band Calibration Register II (Address: 0x82Ah)	30
9.2.44 Battery detect Register (Address: 0x82Bh)	31
9.2.45 TX test Register (Address: 0x82Ch)	31
9.2.46 Rx DEM test Register I (Address: 0x82Dh)	31
9.2.47 Rx DEM test Register II (Address: 0x82Eh)	32
9.2.48 Charge Pump Current Register (Address: 0x82Fh)	32
9.2.49 Crystal test Register (Address: 0x830h)	32
9.2.50 PLL test Register (Address: 0x831h)	32

9.2.51 VCO test Register I (Address: 0x832h).....	33
9.2.52 VCO test Register II (Address: 0x833h).....	33
9.2.53 IFAT Register (Address: 0x834h).....	33
9.2.54 RFT Test Register I (Address: 0x835h).....	33
9.2.55 RFT Test Register II (Address: 0x836h).....	34
9.2.56 RFT Test Register III (Address: 0x837h).....	34
9.2.57 RFT Test Register IV (Address: 0x838h).....	34
9.2.58 RFT Test Register V (Address: 0x839h).....	34
9.2.59 Channel Index Register (Address: 0x83Ah).....	34
9.2.60 CRC Register 1 (Address: 0x83Bh).....	35
9.2.61 CRC Register 2 (Address: 0x83Ch).....	35
9.2.62 CRC Register 3 (Address: 0x83Dh).....	35
9.2.63 CRC Register 4 (Address: 0x83Eh).....	35
9.2.64 CRC Register 5 (Address: 0x83Fh).....	35
9.2.65 CRC Register 6 (Address: 0x840h).....	35
9.2.66 VCO Single band Calibration Register I (Address: 0x841h).....	35
9.2.67 VCO deviation Calibration Register I (Address: 0x842h).....	36
9.2.68 VCO deviation Calibration Register II (Address: 0x843h).....	36
9.2.69 VCO deviation Calibration Register III (Address: 0x844h).....	36
9.2.70 ADC Control Register (Address: 0x845h).....	36
9.2.71 WOT Register (Address: 0x846h).....	37
9.2.72 Channel Group Register I (Address: 0x847h).....	37
9.2.73 Channel Group Register II (Address: 0x848h).....	37
9.2.74 Charge Pump Current Register II (Address: 0x849h).....	37
9.2.75 VCO Modulation Delay Register (Address: 0x84Ah).....	38
9.2.76 Internal Capacitance Register (Address: 0x84Bh).....	38
9.2.77 RX Detection Register (Address: 0x84Ch).....	38
9.2.78 BLE Header Register 0 (Address: 0x84Dh).....	38
9.2.79 BLE Header Register 1 (Address: 0x84Eh).....	38
9.2.80 ID Register 0 (Address: 0x84Fh).....	39
9.2.81 ID Register 1 (Address: 0x850h).....	39
9.2.82 ID Register 2 (Address: 0x851h).....	39
9.2.83 ID Register 3 (Address: 0x852h).....	39
9.2.84 DID Register 0 (Address: 0x853h).....	39
9.2.85 DID Register 1 (Address: 0x854h).....	39
9.2.86 DID Register 2 (Address: 0x855h).....	39
9.2.87 DID Register 3 (Address: 0x856h).....	40
9.2.88 EXT Register 1 (Address: 0x857h).....	40
9.2.89 EXT Register 2 (Address: 0x858h).....	40
9.2.90 EXT Register 3 (Address: 0x859h).....	40
9.2.91 ADC Control Register (Address: 0x85Ah).....	40
9.2.92 ADC Value Register 1 (Address: 0x85Bh).....	41
9.2.93 ADC Value Register 2 (Address: 0x85Ch).....	41
9.2.94 ADC Value Register 3 (Address: 0x85Dh).....	41
9.2.95 Timer Interval Register 1 (Address: 0x85Eh).....	41
9.2.96 Timer Interval Register 2 (Address: 0x85Fh).....	42
9.2.97 Timer Wake On Radio Register 0 (Address: 0x860h).....	42
9.2.98 Timer Wake On Radio Register 1 (Address: 0x861h).....	42
9.2.99 Timer Control Register (Address: 0x862h).....	42
9.2.100 Power Control Register 0 (Address: 0x863h).....	43
9.2.101 Power Control Register 1 (Address: 0x864h).....	43
9.2.102 Power Control Register 2 (Address: 0x865h).....	43
9.2.103 Power Control Register 3 (Address: 0x866h).....	43
9.2.104 Power Control Register 4 (Address: 0x867h).....	43
9.2.105 DC_SHIFT(Address: 0x868h).....	43
9.2.106 TX_5DLY(Address: 0x869h).....	44
9.2.107 ACKRT (Address: 0x87Ch).....	44
10.SOC Architectural Overview.....	45
10.1 Pipeline 8051 CPU.....	45
10.2 Memory Organization.....	45
10.2.1 Program memory.....	45
10.2.2 Data memory.....	45
10.2.3 General Purpose Registers.....	46

10.2.4 Bit Addressable Locations	46
10.2.5 Special Function Registers	46
10.2.6 Stack	46
10.2.7 Data Pointer Register	46
10.2.8 RF Registers and RF FIFO	47
10.3 Instruction set	48
10.4 Interrupt handler	51
10.4.1 FUNCTIONALITY	51
10.5 Reset source	54
10.6 Clock source	56
11. I/O Ports	58
11.1 FUNCTIONALITY	58
11.2 Key interrupt	61
12 Timer0,1 and Timer2	63
12.1 Timer 0 & 1 PINS DESCRIPTION	63
12.2 Timer 0 & 1 FUNCTIONALITY	63
12.2.1 OVERVIEW	63
12.2.2 Timer 0 & 1 Registers	63
12.2.3 Timer 0 – Mode 0	64
12.2.4 Timer 0 – Mode 1	65
12.2.5 Timer 0 – Mode 2	65
12.2.6 Timer 0 – Mode 3	66
12.2.7 Timer 1 – Mode 0	66
12.2.8 Timer 1 – Mode 1	66
12.2.9 Timer 1 – Mode 2	67
12.2.10 Timer 1 – Mode 3	67
12.3 Timer2 PINS DESCRIPTION	67
12.4 Timer2 FUNCTIONALITY	67
12.4.1 OVERVIEW	67
12.4.2 Timer 2 Registers	68
13. UART	71
13.1 UART PINS DESCRIPTION	71
13.2 FUNCTIONALITY	71
13.3 OPERATING MODES	73
13.3.1 UART MODE 0, SYNCHRONOUS	73
13.3.2 UART MODE 1, 8-BIT UART, VARIABLE BAUD RATE, TIMER CLOCK SOURCE	73
13.3.3 UART MODE 2, 9-BIT UART, FIXED BAUD RATE	73
13.3.4 UART MODE 3, 9-BIT UART, VARIABLE BAUD RATE, TIMER CLOCK SOURCE	73
14. IIC interface	74
14.1 Master mode I ² C	74
14.1.1 I ² C REGISTERS	74
14.2.4 I2C MASTER MODULE AVAILABLE SPEED MODES	77
14.2.5 I2C MASTER MODULE AVAILABLE COMMAND SEQUENCES	78
14.3 I2C MASTER MODULE INTERRUPT GENERATION	85
14.5 Slave mode I ² C	85
14.5.1 I2C MODULE INTERNAL REGISTERS	85
14.7 AVAILABLE I2C MODULE TRANSMISSION MODES	87
14.7.1 I ² C module SINGLE RECEIVE	87
14.7.2 I ² C module SINGLE SEND	87
14.7.3 I ² C module BURST RECEIVE	87
14.7.4 I ² C module BURST SEND	88
14.7.5 AVAILABLE I ² C module COMMAND SEQUENCES FLOWCHART	88
14.8 I2C MODULE INTERRUPT GENERATION	89
15. SPI interface	90
15.1 KEY FEATURES	90
15.2 SPI PINS DESCRIPTION	91
15.3 SPI HARDWARE DESCRIPTION	91
15.3.1 BLOCK DIAGRAM	91
15.3.2 INTERNAL REGISTERS	92
15.4 MASTER OPERATIONS	93
15.4.1 MASTER MODE ERRORS	94
15.5 SLAVE OPERATIONS	95
15.5.1 SLAVE MODE ERRORS	95

15.6	CLOCK CONTROL LOGIC	96
15.6.1	SPI CLOCK PHASE AND POLARITY CONTROLS	96
15.6.2	SPI MODULE TRANSFER FORMATS	96
15.6.3	CPHA EQUALS ZERO TRANSFER FORMAT	96
15.6.4	CPHA EQUALS ONE TRANSFER FORMAT	96
15.7	SPI DATA TRANSFER	97
15.7.1	TRANSFER BEGINNING PERIOD (INITIATION DELAY)	97
15.7.2	TRANSFER ENDING PERIOD	97
15.8	TIMING DIAGRAMS	97
15.8.1	MASTER TRANSMISSION	97
15.8.2	SLAVE TRANSMISSION	98
15.9	SPI MODULE INTERRUPT GENERATION	98
16.	PWM	100
16.1	PWM FUNCTIONALITY	100
16.1.1	PWM Registers	100
17.	Watchdog Timer	102
17.1	Watchdog timer overview	102
17.2	Watchdog interrupt	102
17.3	Watchdog Timer reset	103
17.4	SIMPLE TIMER	103
17.5	SYSTEM MONITOR	103
17.6	WATCHDOG RELATED REGISTERS	103
17.7	TIMED ACCESS REGISTERS	104
18.	ADC (Analog to Digital Converter)	106
18.1	8-bits ADC	106
18.1.1	RSSI Measurement	106
18.1.2	Carrier Detect	108
18.2	12-bits SAR ADC	108
19.	Battery Detect	110
20	Power Management	111
21	A8105 RF	113
21.1	Mode Control Register 1 (Address: 0x801h)	113
21.1.1	Strobe Command - Sleep Mode	113
21.1.2	Strobe Command - Idle Mode	113
21.1.3	Strobe Command - Standby Mode	113
21.1.4	Strobe Command - PLL Mode	113
21.1.5	Strobe Command - RX Mode	114
21.1.6	Strobe Command - TX Mode	114
21.2	RF Reset Command	114
21.3	FIFO Accessing Command	114
21.4	Packet Format of FIFO mode	114
21.5	Transceiver Frequency	115
21.5.1	RF Clock	115
21.5.2	LO Frequency Setting	116
21.5.2.1	How to set F _{LO_BASE}	116
21.5.2.2	How to set F _{LO} = F _{LO_BASE} + F _{OFFSET}	117
21.6	State machine	117
21.6.1	Key states	117
21.6.2	FIFO mode	118
22.	Encryption and Authentication	120
22.1	AES	120
22.1.1	AddRoundKey	120
22.1.2	SubBytes	120
22.1.3	ShiftRows	120
22.1.3	MixColumns	120
22.2	CCM	120
23.	Flash memory controller	122
24	In Circuit Emulator (ICE)	124
24.1	PIN define	124
24.2	ICE Key feature	125
25.	Application circuit	126
26.	Abbreviations	127
27.	Ordering Information	128



28. Package Information.....	129
29. Top Marking Information	131
30. Reflow Profile.....	134
31. Tape Reel Information.....	135
32. Product Status	136

AMICCOM CONFIDENTIAL

1. General Description

A8105 is a high performance and low cost 2.4GHz FSK/GFSK system-on-chip (SOC) wireless transceiver. With on chip fraction-N synthesizer, it can support the application of data rate from 5Kbps to 2Mbps and frequency hopping system and it can support peripheral mode of Bluetooth Low Energy. It is a Bluetooth smart device. This device integrates high speed pipeline 8051 MCU, 32/16KBytes In-system programmable flash memory, 2KB SRAM, various powerful functions and excellent performance of a leading 2.4GHz FSK/GFSK RF transceiver. It can be operated with wide voltage from 2.0V ~ 3.6V. A8105 has various operating modes, making it highly suited for systems where ultra-low power consumption is required. Besides, A8105 has two flash memory sizes. One is 16KBytes (A8105F4) and the other is 32Kbytes (A8105F5) that supports AES128 engine and CCM. The device has two package sizes. A8105F4 and A8105F5 are QFN5X5 40 pin package and only A8105F5 has QFN5x5 48pin package.

2. Typical Applications

- 2400 ~ 2483.5 MHz ISM frequency hopping system
- Smart remote controller
- Home and building automation
- Wireless keyboard and mouse
- Wireless toy and gaming
- Helicopter and airplane radio controller
- Bluetooth smart device

3. Feature

- Package size (QFN5 X5, 40 pins/ 48 pins).
- High performance pipeline complicated 8051
- Operation clock: 1, 1/2, 1/4, 1/8, 1/16, 1/32, 1/64 of crystal oscillator.
- 32/16KB Flash memory with copy protection, 2KB SARM
- UART, I²C, SPI serial communication
- Three 16/8-bit counter/timers
- Two Channel PWM
- Watchdog timer
- Sleep timer
- In-Circuit Debugger
- In-System programming/ In-Application programming
- 24/ 28 GPIO(28 I/O only in QFN48)
- RX current consumption with MCU in operation mode :18mA
- TX current consumption with MCU in operation mode (18.5mA @ 0dBm, 21mA @ 6 dBm output power).
- Deep sleep current (0.8 uA)
- Low sleep current (3 uA)
- Frequency band: 2400 – 2483MHz.
- FSK and GFSK modulation
- High sensitivity:
 - ◆ -96dBm at 500Kbps data rate
 - ◆ -92dBm at 1Mbps data rate
 - ◆ -90dBm at 2Mbps data rate
- Programmable data rate 4K ~ 2Mbps.
- Fast settling time synthesizer for frequency hopping system.
- Built-in thermal sensor for monitoring relative temperature.
- Built-in one channel 8-bits ADC for external analog voltage (0V ~ 1.2V).
- Built-in eight channels 12-bits ADC for general purpose analog input (0V ~ 1.8 V).
- Built-in Low Battery Detector.
- Support low cost crystal (8 / 12 / 16 / 24MHz).
- Low cost BLE application
- Easy to use.
 - ◆ Change frequency channel by ONE register setting.
 - ◆ 8-bits Digital RSSI for clear channel indication.
 - ◆ Auto RSSI measurement.
 - ◆ Auto WOR (wake up when receive RX packet).
 - ◆ Auto WOT (wake up to transmit TX packet).
 - ◆ Auto Calibrations.
 - ◆ Auto IF function.
 - ◆ Auto Frequency Compensation.
 - ◆ Auto CRC Check.
 - ◆ Auto FEC by (7, 4) Hamming code (1 bit error correction / code word).
 - ◆ Data Whitening for encryption and decryption.

- ◆ Separated 64 bytes RX and TX FIFO

AMICCOM CONFIDENTIAL

4. Pin Configurations

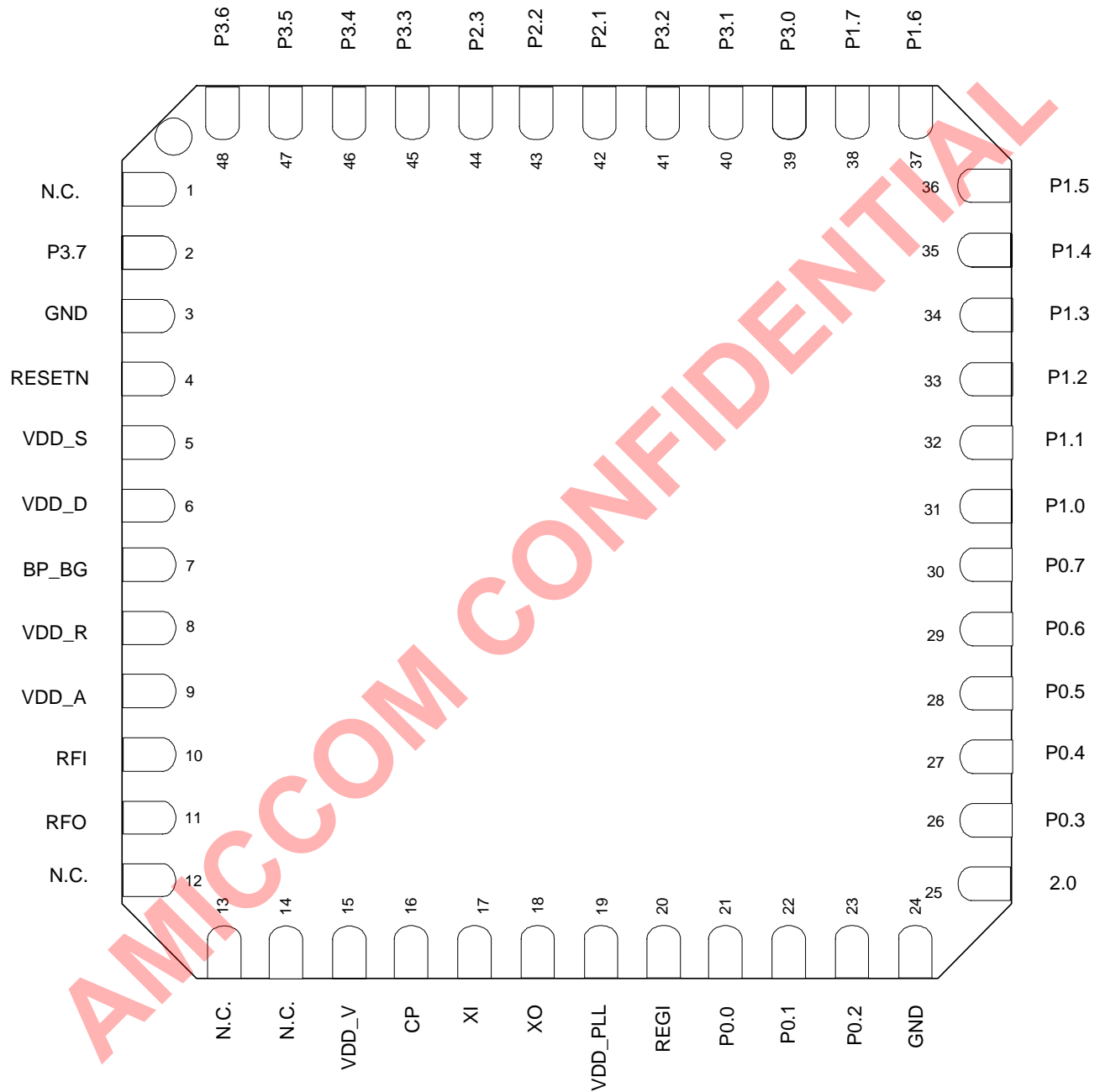

Fig 4-1. A8105 QFN 5x5 48 pin Package Top View

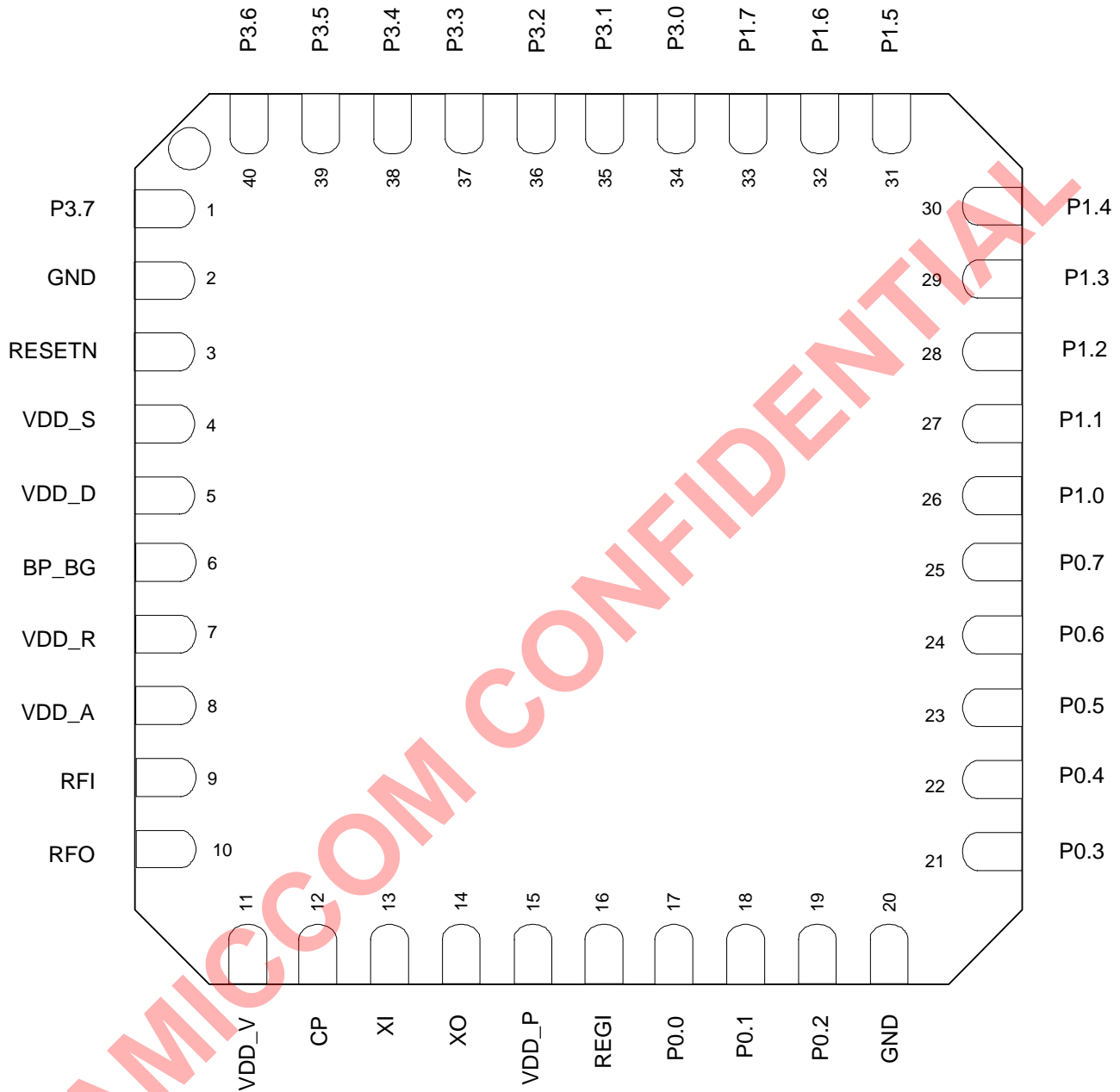

Fig 4-2. A8105 QFN 5x5 40 pin Package Top View

5. Pin Description (I: input; O: output, I/O: input or output)

Pin No.	Symbol	I/O	Function Description
1	NC		
2	P3.7	DIO/AI	RTC_O
3	NC		No connection
4	RESETN	DI	RESETN
5	VDD_S	AO	Voltage supply for SARM
6	VDD_D	AO	VDD_D
7	BP_BG	AO	BP_BG
8	VDD_R	AO	VDD_R
9	VDD_A	AO	VDD_A
10	RFI	AI	RFI
11	RFO	AO	RFO
12	NC		
13	NC		
14	NC		
15	VDD_V	AI	VDD_VCO
16	CP	AO	CP
17	XI	AI	XI
18	XO	AO	XO
19	VDD_P	AO	VDD_PLL
20	REGI	AI	REGI
21	P0.0	DIO	SPI_SCLK
22	P0.1	DIO	SPI_MOSI
23	P0.2	DIO	SPI_MISO
24	GND	DIO	GND
25	P2.0	DIO	P2.0
26	P0.3	DIO	SPI_SSEL
27	P0.4	DIO	GPIO/ ICE mode
28	P0.5	DIO	I2C_SCL
29	P0.6	DIO	I2C_SDA
30	P0.7	DIO	INT2 /GIO1
31	P1.0	DIO	Timer2_T2
32	P1.1	DIO	Timer2_T2EX
33	P1.2	DIO	INT3 /GIO2
34	P1.3	DIO	INT4/ CKO
35	P1.4	DIO	TTAG_TTDIO
36	P1.5	DIO	TTAG_TTCK
37	P1.6	DIO	PWM0/ADC4
38	P1.7	DIO	PWM1/ADC5
39	P3.0	DIO	UART0_RX/ADC6
40	P3.1	DIO	UART0_TX/ADC7

41	P3.2	DIO/AI	INT0/ADC0
42	P2.1	DIO	P2.1
43	P2.2	DIO	P2.2
44	P2.3	DIO	P2.3
45	P3.3	DIO/AI	INT1/ADC1
46	P3.4	DIO/AI	Timer0_T0/ADC2
47	P3.5	DIO/AI	Timer1_T1/ADC3
48	P3.6	DIO/AI	RTC_I

Table 5-1 QFN5x5 48 Pin

Pin No.	Symbol	I/O	Function Description
1	P3.7	DIO/AI	RTC_O
2	NC		No connection
3	RESETN	DI	RESETN
4	VDD_S	AO	Voltage supply for SARM
5	VDD_D	AO	VDD_D
6	BP_BG	AO	BP_BG
7	VDD_R	AO	VDD_R
8	VDD_A	AO	VDD_A
9	RFI	AI	RFI
10	RFO	AO	RFO
11	VDD_VCO	AI	VDD_VCO
12	CP	AO	CP
13	XI	AI	XI
14	XO	AO	XO
15	VDD_PLL	AO	VDD_PLL
16	REGI	AI	REGI
17	P0.0	DIO	SPI_SCLK
18	P0.1	DIO	SPI_MOSI
19	P0.2	DIO	SPI_MISO
20	GND	DIO	GND
21	P0.3	DIO	SPI_SSEL
22	P0.4	DIO	GPIO/ ICE mode
23	P0.5	DIO	I2C_SCL
24	P0.6	DIO	I2C_SDA
25	P0.7	DIO	INT2 /GIO1
26	P1.0	DIO	Timer2_T2
27	P1.1	DIO	Timer2_T2EX
28	P1.2	DIO	INT3 /GIO2
29	P1.3	DIO	INT4/ CKO
30	P1.4	DIO	TTAG_TTDIO
31	P1.5	DIO	TTAG_TTCK

32	P1.6	DIO	PWM0/ADC4
33	P1.7	DIO	PWM1/ADC5
34	P3.0	DIO	UART0_RX/ADC6
35	P3.1	DIO	UART0_TX/ADC7
36	P3.2	DIO/AI	INT0/ADC0
37	P3.3	DIO/AI	INT1/ADC1
38	P3.4	DIO/AI	Timer0_T0/ADC2
39	P3.5	DIO/AI	Timer1_T1/ADC3
40	P3.6	DIO/AI	RTC_I

Table 5-1 QFN5x5 40 Pin

6. Chip Block Diagram

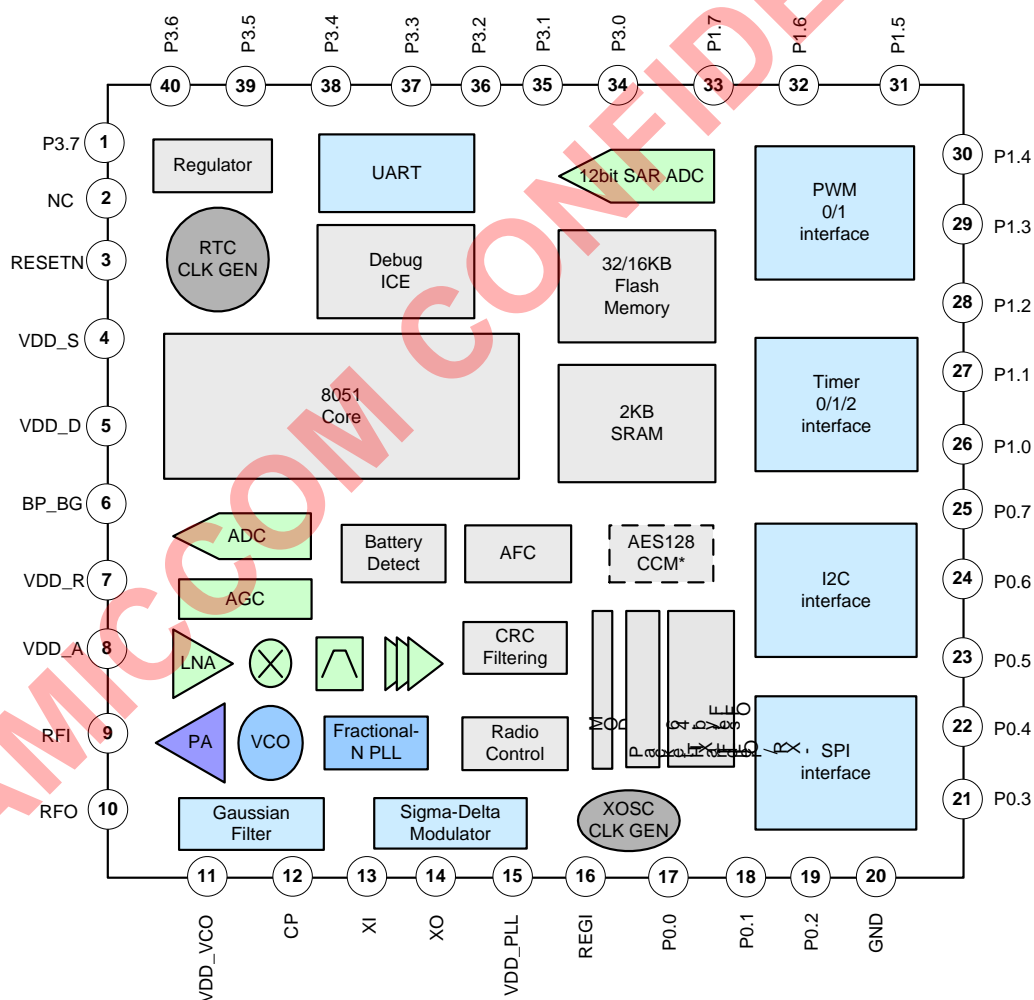

Fig 6-1. A8105 QFN5x5 40 pin Block Diagram

Note*: Only 32KBytes version (A8105F5) support AES128/CCM*.

7. Absolute Maximum Ratings

Parameter	With respect to	Rating	Unit
Supply voltage range (VDD)	GND	-0.3 ~ 3.6	V
Digital IO pins range	GND	-0.3 ~ VDD+0.3	V
Voltage on the analog pins range	GND	-0.3 ~ 2.1	V
Input RF level		14	dBm
Storage Temperature range		-55 ~ 125	°C
ESD Rating	HBM	± 2K	V
	MM	± 100	V

*Stresses above those listed under “Absolute Maximum Rating” may cause permanent damage to the device. These are stress ratings only; functional operation of the device at these or any other conditions above those indicated in the operational sections of this specification is not implied. Exposure to absolute-maximum-rated conditions for extended periods may affect device reliability.

*Device is ESD sensitive. Use appropriate ESD precautions. HBM (Human Body Mode) is tested under MIL-STD-883F Method 3015.7. MM (Machine Mode) is tested under JEDEC EIA/JESD22-A115-A.

*Device is Moisture Sensitivity Level III (MSL 3).



AMICCOM CONFIDENTIAL

8. Electrical Specification

(Ta=25°C, REGI = 3.3V, internal regulator voltage = 1.8V, unless otherwise noted)

Parameter	Description	Min.	Type	Max.	Unit
General					
Operating Temperature		-40		85	°C
Supply Voltage	With internal regulator	2.0		3.6	V
Current Consumption (MCU only, RF in sleep mode)	Deep Sleep		0.8		uA
	Sleep(WOR/TWOR off)		3		uA
	Sleep (WOR /TWOR wake)		5		uA
	Normal		2.5		mA
Current Consumption (RF with MCU in normal mode)	Standby Mode		3		mA
	PLL Mode		9.5		mA
	RX Mode (AGC Off)		17.5		mA
	RX Mode (AGC On)		18		mA
	TX Mode (@0dBm output)		18.5		mA
	TX Mode (@6dBm output)		23.5		mA
Synthesizer block (includes crystal oscillator, PLL and VCO.)					
Crystal start up time	Idle to standby (Xtal, 49US type, is stable at 40ppm)		0.6		ms
Crystal frequency			16		MHz
Crystal ESR				80	ohm
VCO Operation Frequency		2400		2483.5	MHz
PLL phase noise	Offset 100k		80		dBc
	Offset 500K		95		
	Offset 1M		105		
PLL settling time	@Loop BW = 100Khz		75		μS
TX					
Output power range		-10	0	10	dBm
Out Band Spurious Emission ¹	30MHz~1GHz			-36	dBm
	1GHz~12.75GHz			-30	dBm
	1.8GHz~ 1.9GHz			-47	dBm
	5.15GHz~ 5.3GHz			-47	dBm
Frequency deviation	500Kbps		186K		Hz
	1M		250K		Hz
	2M		500K		Hz
Data rate		4K		2M	Bps
TX settling time	Loop bandwidth 100K		70		μS
RX					
Receiver sensitivity @ BER = 0.1%	Data rate 2M (F _{IF} = 2MHz)		-90		dBm
	Data rate 1M (F _{IF} = 1MHz)		-92		dBm
	Data rate 500K (F _{IF} = 1MHz)		-96		dBm
IF frequency bandwidth			1200/2400		KHz
IF center frequency			1000/2000		KHz
Interference	Co-Channel (C/I ₀)		11		dB
	1 st Adjacent Channel (C/I ₁)		2		dB

	2 nd Adjacent Channel (C/I ₂)		-18		dB
	3 rd Adjacent Channel (C/I ₃)		-28		dB
	Image (C/I _{IM})		-12		dB
Maximum Operating Input Power	@RF input (BER=0.1%)			0	dBm
Spurious Emission	30MHz~1GHz			-52	dBm
	1GHz~12.75GHz			-47	dBm
RSSI Range with AGC turn on	@RF input	-100		-10	dBm
12Bit SAR ADC					
Input voltage range		0		1.8	V
External reference voltage			1.8		V
Input capacitor			25		pF
Bandwidth			200		KHz
EOB, effective number of bits			10		bit
INL			+/- 2		LSB
DNL			+/- 1		LSB
Conversion time		128		8	uS
Current consumption			0.4		mA
Regulator					
Regulator settling time	Pin 19 connected to 1nF		200		μs
Band-gap reference voltage			1.21		V
Regulator output voltage			1.8		V
Digital IO DC characteristics					
High Level Input Voltage (V _{IH})		0.8*VDD		VDD	V
Low Level Input Voltage (V _{IL})		0		0.2*VDD	V
High Level Output Voltage (V _{OH})	@I _{OH} = -0.5mA	VDD-0.4		VDD	V
Low Level Output Voltage (V _{OL})	@I _{OL} = 0.5mA	0		0.4	V

9. SFR & RFR(Radio Frequency Register)

A8105 contains standard 8051 SFRs(special function registers) and RFR (RF control registers). A8051's SFR location is almost the same as the standard 8052 SFR location. RFR is Radio Frequency Registers are located in XDATA spaces and located in 0x0800 ~ 0x08FF. For more detail information, please reference Section 9.2.

9.1 SFR Overview

Table 9.1 A8105 Special Function Registers (SFRs) table

	0/8	1/9	2/A	3/B	4/C	5/D	6/E	7/F
0xF8	EIP	OSCCON						
0xF0	B	I2CSADR	I2CSCR	I2CSBUF	I2CMSA	I2CMCR	I2CMBUF	I2CMTP
0xE8	EIE				SPCR	SPSR	SPDR	SSCR
0xE0	ACC	P3OE	P3PUN	P3WUN	SPCR1	SPSR1	SPDR1	SSCR1
0xD8	WDCON	P1OE	P1PUN	P1WUN				
0xD0	PSW	P0OE	P0PUN	P0WUN				
0xC8	T2CON	T2IF	RLDL	RLDH	TL2	TH2		DEVICR
0xC0								
0xB8	IP	PCONE	RSFLAG	IOSEL	ADCCH			
0xB0	P3	PWM1CON	PWM1H	PWM1L				
0xA8	IE	PWM0CON	PWM0H	PWM0L				
0xA0	P2	P2OE	P2PUN	P2WUN				
0x98	SOCN0	SBUF0	FLASHCTRL	FLASHMR				
0x90	P1	EIF					USBADDR	USBDATA
0x88	TCON	TMOD	TL0	TL1	TH0	TH1	CKCON	DMAIR
0x80	P0	SP	DPL0	DPH0	DPL1	DPH1	DPS	PCON

: It means bit-addressable

: It means reserved.

Following are description of SFRs related to the operation of A8105 System Controller. Detailed descriptions of the remaining SFRs are including the sections of the datasheet associated with their corresponding system function. The arithmetic section of the processor performs extensive data manipulation and is comprised of the 8-bit arithmetic logic unit (ALU), an ACC(0xE0) register, B(0xF0) register and PSW(0xD0) register.

PSW (Address: D0h)

Address/Name	R/W	Bit 7	Bit 6	Bit 5	Bit 4	Bit 3	Bit 2	Bit 1	Bit 0
D0h PSW	R/W	CY	AC	F0	RS1	RS2	OV	F1	P
Reset		0	0	0	0	0	0	0	0

Program Status Word register

The ALU performs typical arithmetic operations as: addition, subtraction, multiplication, division and additional operations such as: increment, decrement, BCD-decimal-add-adjust and compare. Within logic unit are performance: AND, OR, Exclusive OR, complement and rotation. The Boolean processor performance the bit operations as: set, clear, complement, jump-if-not-set, jump-if-set-and-clear and move to/from carry.

CY - Carry flag

AC - Auxiliary carry

F0 - General purpose flag 0

RS[1:0] - Register bank select bits

RS[1:0]	Function description
00	- Bank 0, data address 0x00-0x07
01	- Bank 1, data address 0x08-0x0F
10	- Bank 2, data address 0x10-0x17
11	- Bank 3, data address 0x18-0x1F

OV - Overflow flag

F1 - General purpose flag 1

P - Parity flag

The PSW contains several bits that reflect the current state of the CPU.

ACC (Address: E0h)

Address/Name	R/W	Bit 7	Bit 6	Bit 5	Bit 4	Bit 3	Bit 2	Bit 1	Bit 0
E0h ACC	R/W								
Reset		0	0	0	0	0	0	0	0

Accumulator ACC Register

B (Address: F0h)

Address/Name	R/W	Bit 7	Bit 6	Bit 5	Bit 4	Bit 3	Bit 2	Bit 1	Bit 0
F0h B	R/W								
Reset		0	0	0	0	0	0	0	0

B Register

The B register is used during multiply and divide operations. In other cases may be used as normal SFR.

9.2 RFR Overview

Address / Name	R/W	Bit 7	Bit 6	Bit 5	Bit 4	Bit 3	Bit 2	Bit 1	Bit 0
0x800h MODE	W	RESETN	FWPRN	FRPRN	ADC12RN	--	BFCRN	--	--
	R	--	FECF	CRCF	CER	XER	PLLER	TRSR	TRER
0x801h MODEC1	W	STRB7	STRB6	STRB5	STRB4	STRB3	STRB2	STRB1	STRB0
	R	WTR	P_CKO	P_IRQ10	P_IRQ20	FPF	--	--	--
0x802h MODEC2	W		ARSSI	AIF	DFCD	WWSE	FMT	FMS	ADCM
	R		ARSSI	AIF	CD	WWSE	FMT	FMS	ADCM
0x803h CALC	R/W	WWS_AC 7	WWS_AC 6	FIFOREV	RSSC	VDC	VCC	VBC	FBC
0x804h FIFO I	W	FEP7	FEP6	FEP5	FEP4	FEP3	FEP2	FEP1	FEP0
0x805h FIFO II	W	FPM1	FPM0	PSA5	PSA4	PSA3	PSA2	PSA1	PSA0
0x806h RC OSC 1	W	WWS_SL7	WWS_SL6	WWS_SL5	WWS_SL4	WWS_SL3	WWS_SL2	WWS_SL1	WWS_SL0
0x807h RC OSC 2	W	WWS_SL9	WWS_SL8	WWS_AC 5	WWS_AC 4	WWS_AC 3	WWS_AC 2	WWS_AC 1	WWS_AC 0
0x808h RC OSC 3	W	BBCKS1	BBCKS0	--	CRCSW	BLE_ON	RCTS	TSEL	TWOR_E
0x809h RC OSC 4	W	RCOT[2:0]			WCKSEL[1:0]		MVS[1:0]		ENCAL
	R	NUMLH[11:8]				--	RCOC[9:8]		ENCAL
0x80Ah RC OSC 5	W	MRCT9	MRCT8	--	--	--	TMRE	MAN	MCALS
	R	NUMLH7	NUMLH6	NUMLH5	NUMLH4	NUMLH3	NUMLH2	NUMLH1	NUMLH0
0x80Bh RC OSC 6	W	MRCT7	MRCT6	MRCT5	MRCT4	MRCT3	MRCT2	MRCT1	MRCT0
	R	RCOC7	RCOC6	RCOC5	RCOC4	RCOC3	RCOC2	RCOC1	RCOC0
0x80Ch RC OSC 7	W	TGNUM[11:8]							
0x80Dh RC OSC 8	W	TGNUM[7:0]							
0x80Eh CKO Pin	W	DOCKOE	CKOS3	CKOS2	CKOS1	CKOS0	CKOI	WAKEBBIE	INTT1IE
0x80Fh GPIO1 Pin I	W	VGC1	VGC0	GIO1S3	GIO1S2	GIO1S1	GIO1S0	GIO1I	--
0x810h GPIO2 Pin II	W	HBW	WWS_AC 8	GIO2S3	GIO2S2	GIO2S1	GIO2S0	GIO2I	--
0x811h Clock	R/W	GRC3	GRC2	GRC1	GRC0	IDREV	CSC0	CGS	XS
0x812h Data rate	R/W	SDR7	SDR6	SDR5	SDR4	SDR3	SDR2	SDR1	SDR0
0x813h PLL I	R/W	CHN7	CHN6	CHN5	CHN4	CHN3	CHN2	CHN1	CHN0
0x814h PLL II	R/W	DBL	RRC1	RRC0	CHR3	CHR2	CHR1	CHR0	IP8
0x815h PLL III	R/W	IP7	IP6	IP5	IP4	IP3	IP2	IP1	IP0
0x816h PLL IV	W	FP15	FP14	FP13	FP12	FP11	FP10	FP9	FP8
	R	--	AC14	AC13	AC12	AC11	AC10	AC9	AC8
0x817h PLL V	W	FP7	FP6	FP5	FP4	FP3	FP2	FP1	FP0
	R	AC7	AC6	AC5	AC4	AC3	AC2	AC1	AC0
0x818h TX I	W	GDR	TMDE	TXDI	TME	FS	FDP2	FDP1	FDP0
0x819h TX II	W	FD7	FD6	FD5	FD4	FD3	FD2	FD1	FD0
0x81Ah Delay I	W	DPR2	DPR1	DPR0	TDL1	TDL0	PDL2	PDL1	PDL0
0x81Bh Delay II	W	WSEL2	WSEL1	WSEL0	AGC_D1	AGC_D0	RS_DLY2	RS_DLY1	RS_DLY0

0x81Ch RX	W	MSCRC	RXSM1	RXSM0	AFC	RXDI	DMG	BWS	ULS
0x81Dh RX Gain I	W	AGCE	MIC	IGC1	IGC0	MGC1	MGC0	LGC1	LGC0
	R	ADC8	MICR	IGCR1	IGCR0	MGCR1	MGCR0	LGCR1	LGCR0
0x81Eh RX Gain II	W	PKIS1	PKIS0	PKT1	PKT0	DCH1	DCH0	RSAGC1	RSAGC0
	R	--	--	--	--	--	--	VTB1	VTB0
0x81Fh RX Gain III	W	IFPK	VRSEL	MS	MSCL4	MSCL3	MSCL2	MSCL1	MSCL0
	R	RH7	RH6	RH5	RH4	RH3	RH2	RH1	RH0
0x820h RX Gain IV	W	MXD	CSS	HPLS	MHC1	MHC0	LHC1	LHC0	XADSP
	R	RL7	RL6	RL5	RL4	RL3	RL2	RL1	RL0
0x821h RSSI Threshold	W	RTH7	RTH6	RTH5	RTH4	RTH3	RTH2	RTH1	RTH0
	R	ADC7	ADC6	ADC5	ADC4	ADC3	ADC2	ADC1	ADC0
0x822h ADC	W	RSM1	RSM0	ERSS	FSARS	SYNCS	XADS	RSS	CDM
0x823h Code I	W	XDS	MCS	WHTS	FECS	CRCS	PML2	PML1	PML0
0x824h Code II	W	DCL2	DCL1	DCL0	ETH2	ETH1	ETH0	PMD1	PMD0
0x825h Code III	W	IDL	WS6	WS5	WS4	WS3	WS2	WS1	WS0
0x826h IF Calibration I	W	RNUM0_2	RNUM0_1	RNUM0_0	MFBS	MFB3	MFB2	MFB1	MFB0
	R	--	--	--	FBCF	FB3	FB2	FB1	FB0
0x827h IF Calibration II	W	PWORS	TRT2	TRT1	TRT0	MRCKS	RNUM1_2	RNUM1_1	RNUM1_0
	R	--	--	--	FCD4	FCD3	FCD2	FCD1	FCD0
0x828h VCO current Calibration	W	--	PKS	VCCS	MVCS	VCOC3	VCOC2	VCOC1	VCOC0
	R	TWORF	--	--	FVCC	VCB3	VCB2	VCB1	VCB0
0x829h VCO band Calibration I	W	DCD1	DCD0	DAGS	PDV	MVBS	MVB2	MVB1	MVB0
	R	--	--	--	--	VBCF	VB2	VB1	VB0
0x82Ah VCO band Calibration II	W	DAMV1	DAMV0	VTH2	VTH1	VTH0	VTL2	VTL1	VTL0
0x82Bh Battery detect	W	RGS	RGV1	RGV0	PACTL	BVT2	BVT1	BVT0	BDS
	R	--	RGV1	RGV0	BDF	BVT2	BVT1	BVT0	BDS
0x82Ch TX test	W	IFBC1	IFBC0	TXCS	PAC1	PAC0	TBG2	TBG1	TBG0
0x82Dh Rx DEM test I	W	DMT	DCM1	DCM0	MLP1	MLP0	SLF2	SLF1	SLF0
0x82Eh Rx DEM test II	W	DCV7	DCV6	DCV5	DCV4	DCV3	DCV2	DCV1	DCV0
0x82Fh Charge Pump Current I	W	CPM3	CPM2	CPM1	CPM0	CPT3	CPT2	CPT1	CPT0
0x830h Crystal test	W	PRS	QDS	QCLIM	DBD	XCC1	XCC0	XCP1	XCP0
0x831h PLL test	W	MDEN	PMPE	PRIC1	PRIC0	PRRC1	PRRC0	SDPW	NSDO
0x832h VCO test I	W	DEVG2	DEVG1	DEVG0	TLB1	TLB0	RLB1	RLB0	MGS
0x833h VCO test II	W	CHD3	CHD2	CHD1	CHD0	RFT3	RFT2	RFT1	RFT0
0x834h IFAT	W	MPDT5	MPDT4	MPDT3	MPDT2	MPDT1	MPDT0	--	LIMC
0x835h RF test I	W	ASMV2	ASMV1	ASMV0	SDMS	OLM	CPCS	CPH	CPS
0x836h RF test II	W	--	CRS3	CRS2	CRS1	CRS0	SRS2	SRS1	SRS0
	R	--	CRSR3	CRSR2	CRSR1	CRSR0	SRSR2	SRSR1	SRSR0
0x837h	W	--	STMP	STM5	STM4	STM3	STM2	STM1	STM0

RF test III	R	--	--	STMR5	STMR4	STMR3	STMR2	STMR1	STMR0
0x838h	W	--	DVI1	DVI0	FBG4	FBG3	FBG2	FBG1	FBG0
RF test IV	R	--	--	--	FBGR4	FBGR3	FBGR2	FBGR1	FBGR0
0x839h	W	FGC1	FGC0	CTR5	CTR4	CTR3	CTR2	CTR1	CTR0
RF test V	R	FGCR1	FGCR0	CTRR5	CTRR4	CTRR3	CTRR2	CTRR1	CTRR0
0x83Ah Channel Index	W	--	--	CHIDX[5:0]					
0x83Bh CRC1	W	CRCINIT2 3	CRCINIT2 2	CRCINIT2 1	CRCINIT2 0	CRCINIT1 9	CRCINIT1 8	CRCINIT1 7	CRCINIT1 6
0x83Ch CRC2	W	CRCINIT1 5	CRCINIT1 4	CRCINIT1 3	CRCINIT1 2	CRCINIT1 1	CRCINIT1 0	CRCINIT9	CRCINIT8
0x83Dh CRC3	W	CRCINIT7	CRCINIT6	CRCINIT5	CRCINIT4	CRCINIT3	CRCINIT2	CRCINIT1	CRCINIT0
0x83Eh CRC4	W	CRCINR2 3	CRCINR2 2	CRCINR2 1	CRCINR2 0	CRCINR1 9	CRCINR1 8	CRCINR1 7	CRCINR1 6
0x83Fh CRC5	W	CRCINR1 5	CRCINR1 4	CRCINR1 3	CRCINR1 2	CRCINR1 1	CRCINR1 0	CRCINR9	CRCINR8
0x840h CRC6	W	CRCINR7	CRCINR6	CRCINR5	CRCINR4	CRCINR3	CRCINR2	CRCINR1	CRCINR0
0x841h VCO band Calibration III	W	MDAG7	MDAG6	MDAG5	MDAG4	MDAG3	MDAG2	MDAG1	MDAG0
	R	ADAG7	ADAG6	ADAG5	ADAG4	ADAG3	ADAG2	ADAG1	ADAG0
0x842h VCO deviation Calibration I	W	DEVS3	DEVS2	DEVS1	DEVS0	DAMR_M	VMTE_M	VMS_M	MSEL
	R	DEVA7	DEVA6	DEVA5	DEVA4	DEVA3	DEVA2	DEVA1	DEVA0
0x843h VCO deviation Calibration II	W	MVDS	DEVM6	DEVM5	DEVM4	DEVM3	DEVM2	DEVM1	DEVM0
	R	ADEV7	ADEV6	ADEV5	ADEV4	ADEV3	ADEV2	ADEV1	ADEV0
0x844h VCO deviation Calibration III	W/R	VMG7	VMG6	VMG5	VMG4	VMG3	VMG2	VMG1	VMG0
0x845h ADC Control	W	AVSEL1	AVSEL0	MVSEL1	MVSEL0	RADC	FPS2	FPS1	FPS0
0x846h WOT	W	--	SPSS	WMODE	WN1	WN0			
0x847h Channel Group I	R/W	CHGL7	CHGL6	CHGL5	CHGL4	CHGL3	CHGL2	CHGL1	CHGL0
0x848h Channel Group II	R/W	CHGH7	CHGH6	CHGH5	CHGH4	CHGH3	CHGH2	CHGH1	CHGH0
0x849h Charge Pump Current II	W	CPTX3	CPTX2	CPTX1	CPTX0	CPRX3	CPRX2	CPRX1	CPRX0
0x84Ah VCO modulation Delay	W	--	INTPRC	DEVFD2	DEVFD1	DEVFD0	DEV2	DEV1	DEV0
0x84Bh INTC	W	VRPL1	VRPL0	VCOSC5	VCOSC4	VCOSC3	VCOSC2	VCOSC1	VCOSC0
0x84Ch DET	W	DC_SEL	RXDCS	PREDN2	PREDN1	PREDN0	PREUP2	PREUP1	PREUP0
	R	DCOUT[7:0]							
0x84Dh BLE_HEADER0	W	TX_HEAD ER15	TX_HEAD ER14	TX_HEAD ER13	TX_HEAD ER12	TX_HEAD ER11	TX_HEAD ER10	TX_HEAD ER9	TX_HEAD ER8
	R	RX_HEAD ER15	RX_HEAD ER14	RX_HEAD ER13	RX_HEAD ER12	RX_HEAD ER11	RX_HEAD ER10	RX_HEAD ER9	RX_HEAD ER8
0x84Eh BLE_HEADER1	W	TX_HEAD ER7	TX_HEAD ER6	TX_HEAD ER5	TX_HEAD ER4	TX_HEAD ER3	TX_HEAD ER2	TX_HEAD ER1	TX_HEAD ER0
	R	RX_HEAD ER7	RX_HEAD ER6	RX_HEAD ER5	RX_HEAD ER4	RX_HEAD ER3	RX_HEAD ER2	RX_HEAD ER1	RX_HEAD ER0
0x84Fh ID0	W/R	ID31	ID30	ID29	ID28	ID27	ID26	ID25	ID24
0x850h ID1	W/R	ID23	ID22	ID21	ID20	ID19	ID18	ID17	ID16

0x851h ID2	W/R	ID15	ID14	ID13	ID12	ID11	ID10	ID9	ID8
0x852h ID3	W/R	ID7	ID6	ID5	ID4	ID3	ID2	ID1	ID0
0x853h DID0	R	DID31	DID30	DID29	DID28	DID27	DID26	DID25	DID24
0x854h DID1	R	DID23	DID22	DID21	DID20	DID19	DID18	DID17	DID16
0x855h DID2	R	DID15	DID14	DID13	DID12	DID11	DID10	DID9	DID8
0x856h DID3	R	DID7	DID6	DID5	DID4	DID3	DID2	DID1	DID0
0x857h EXT1	W/R	--	XEC	BREV	BGS	LIMB	ADCCS	BOD	REGR
0x858h EXT2	W	VTRB3	VTRB2	VTRB1	VTRB0	VMRB3	VMRB2	VMRB1	VMRB0
0x859h EXT3	W	--	IFAS	CGC	IWA	IWC	LBG	VCS	VCSW
0x85Ah ADCCTL	W	BUFS	CKS	--	MODE	MVS2	MVS1	MVS0	ADCE
	R	--	--	--	MODE	MVS2	MVS1	MVS0	ADCE
0x85Bh ADCAVG1	W	ADCIE	--	--	--	ADIVL	ADCYC	ENADC	DTMP
	R	MVADC11	MVADC10	MVADC9	MVADC8	ADC11	ADC10	ADC9	ADC8
0x85Ch ADCAVG2	R	MVADC7	MVADC6	MVADC5	MVADC4	MVADC3	MVADC2	MVADC1	MVADC0
0x85Dh ADCAVG3	R	ADC7	ADC6	ADC5	ADC4	ADC3	ADC2	ADC1	ADC0
0x85Eh TMRITV1	W	TMR_ITV[15:8]							
0x85Fh TMRITV2	W	TMR_ITV[7:0]							
0x860h TMRWOR0	W	--							
0x861h TMRWOR1	W	TMRWORS	--	-	TMR_OFS4	TMR_OFS3	TMR_OFS2	TMR_OFS1	TMR_OFS0
0x862h TMRCTL	W	TMRON	TMRIE	TMRIF	TMRCOR	TMRWOR	TMRCKS1	TMRCKS0	TMR_CE
	R	--	TMRIE	TMRIF	--	--	TMRCKS1	TMRCKS0	TMR_CE
0x863h PWRCTL0	W	CBG2	CBG1	CBG0	PDNS	STA	ENDL2	ENDL1	ENDL0
0x864h PWRCTL1	W	EBOD	ENAV	QDSA	ENDV	QDSD	CEL	SVREF	CELA
0x865h PWRCTL2	W	P3PUNIE	--	--	RCR1	RCR0	RGC1	RGC0	RCHC
0x866h PWRCTL3	W	MR[7:0] (analog)							
0x867h PWRCTL4	W	MS[7:0] (analog)							
0x868h DCSFT	W	dc_shift[7:0]							
0x869h TX5DY	W/R	HDRSW	EARTS	EACKS	TX_5DLY[4:0]				
0x87Ch ACKRT	W	--	--	LL_TIME_OUT[5:0]					

Legend: - = unimplemented

9.2.1 Mode Register (Address: 0x800h)

Name	R/W	Bit 7	Bit 6	Bit 5	Bit 4	Bit 3	Bit 2	Bit 1	Bit 0
MODE	W	RESETN	FWPRN	FRPRN	ADC12RN	--	BFCRN	--	--
	R	--	FECF	CRCF	CER	XER	PLLER	TRSR	TRER
Reset		--	--	--	--	--	--	--	--

RESETN: Write to this register by 0x00 to issue reset command, then it is auto clear

FWPRN: FIFO Write Point Software Reset.

FRPRN: FIFO Read Point Software Reset.

ADC12RN: 12-bits ADC Software Reset.

BFCRN: IF Filter Bank Calibration Software Reset.

FECF: FEC flag.

[0]: FEC pass. [1]: FEC error.

CRCF: CRC flag.

[0]: CRC pass. [1]: CRC error.

CER: RF chip enable status.

[0]: RF chip is disabled. [1]: RF chip is enabled.

XER: Internal crystal oscillator enabled status.

[0]: Crystal oscillator is disabled. [1]: Crystal oscillator is enabled.

PLLER: PLL enabled status.

[0]: PLL is disabled. [1]: PLL is enabled.

TRSR: TRX Status Register.

[0]: RX state. [1]: TX state.

Serviceable if TRER=1 (TRX is enable).

TRER: TRX state enabled status.

[0]: TRX is disabled. [1]: TRX is enabled.

9.2.2 Mode Control Register 1 (Address: 0x801h)

Name	R/W	Bit 7	Bit 6	Bit 5	Bit 4	Bit 3	Bit 2	Bit 1	Bit 0
MODEC1	W	STRB7	STRB6	STRB5	STRB4	STRB3	STRB2	STRB1	STRB0
	R	ARCWTR	P_CKO	P_IRQ10	P_IRQ20	FSYNC			
Reset		1	0	1	0	0	0	0	0

STRB[7:0]: Strobe command register.

[80]: Sleep mode.

[90]: Idle mode.

[A0]: Standby mode.

[B0]: PLL mode.

[C0]: TX mode.

[D0]: RX mode.

Reverse for other settings.

ARCWTR: Read ARCWTR output signal.

P_CKO: Read P_CKO pin output signal.

P_IRQ10: Read P_IRQ10 pin output signal.

P_IRQ20: Read P_IRQ20 pin output signal.

FSYNC: Read Frame sync ok output signal.

9.2.3 Mode Control Register 2 (Address: 0x802h)

Name	R/W	Bit 7	Bit 6	Bit 5	Bit 4	Bit 3	Bit 2	Bit 1	Bit 0
MODEC2	W		ARSSI	AIF	DFCD	WWSE	FMT	FMS	ADCM
	R		ARSSI	AIF	CD	WWSE	FMT	FMS	ADCM
Reset			0	0	0	0	0	0	0

ARSSI: Auto RSSI measurement while entering RX mode.

[0]: Disable. [1]: Enable.

AIF (Auto IF Offset): RF LO frequency will auto offset one IF frequency while entering RX mode.

[0]: Disable. [1]: Enable.

CD / DFCD:

DFCD (Data Filter by CD): The received package will be filtered out if Carrier Detector signal is inactive.

[0]: Disable. [1]: Enable.

CD (Read): Carrier detector signal.

[0]: Input power below threshold. [1]: Input power above threshold.

WWSE: Reserved for internal usage only. Shall be set to [0].

FMT: Reserved for internal usage only. Shall be set to [0].

FMS: Direct/FIFO mode select.

[0]: Direct mode. [1]: FIFO mode.

ADCM: ADC measurement enable (Auto clear when done).

[0]: Disable measurement or measurement finished. [1]: Enable measurement.

ADCM	A8105 @ Standby mode	A8105 @ RX mode
[0]	Disable ADC	D i s a b l e A D C
[1]	Measure temperature, external Analog Digital Convert	Measure RSSI, carrier detect

9.2.4 Calibration Control Register (Address: 0x803h)

Name	R/W	Bit 7	Bit 6	Bit 5	Bit 4	Bit 3	Bit 2	Bit 1	Bit 0
CALC	W	WWS_AC 7	WWS_AC 6	FIFOREV	RSSC	VDC	VCC	VBC	FBC
	R								
Reset		--	--	--	0	0	0	0	0

WWS_AC [7:6]: See 9.2.8

FIFOREV: FIFO reverse enable.

[0]: Disable. [1]: Enable

RSSC: RSSI calibration enable (Auto clear when done).

[0]: Disable. [1]: Enable.

VCC: VCO Current calibration enable (Auto clear when done).

[0]: Disable. [1]: Enable.

VBC: VCO Bank calibration enable (Auto clear when done).

[0]: Disable. [1]: Enable.

VDC: VCO Deviation calibration enable (Auto clear when done).

[0]: Disable. [1]: Enable.

FBC: IF Filter Bank calibration enable (Auto clear when done).
[0]: Disable. **[1]:** Enable.

9.2.5 FIFO Register I (Address: 0x804h)

Name	R/W	Bit 7	Bit 6	Bit 5	Bit 4	Bit 3	Bit 2	Bit 1	Bit 0
FIFO I	W	FEP7	FEP6	FEP5	FEP4	FEP3	FEP2	FEP1	FEP0
Reset		0	0	1	1	1	1	1	1

FEP [7:0]: FIFO End Pointer for TX FIFO and Rx FIFO.
 Refer to chapter chapter 21 for details.

9.2.6 FIFO Register II (Address: 0x805h)

Name	R/W	Bit 7	Bit 6	Bit 5	Bit 4	Bit 3	Bit 2	Bit 1	Bit 0
FIFO II	W	FPM1	FPM0	PSA5	PSA4	PSA3	PSA2	PSA1	PSA0
Reset		0	1	0	0	0	0	0	0

FPM [1:0]: FIFO Pointer Margin

PSA [5:0]: Used for Segment FIFO.
 Refer to chapter 21 for details.

9.2.7 RC OSC Register I (Address: 0x806h)

Name	R/W	Bit 7	Bit 6	Bit 5	Bit 4	Bit 3	Bit 2	Bit 1	Bit 0
RC OSC I	W	WWS_SL7	WWS_SL6	WWS_SL5	WWS_SL4	WWS_SL3	WWS_SL2	WWS_SL1	WWS_SL0
Reset		0	0	0	0	0	0	0	0

WWS_SL [9:0]: 10-bits WWS_SL Timer for TWWS Function (7.8ms ~ 7.99s).
 WWS_SL [9:0] are from address (0x806h) and (0x807h).

9.2.8 RC OSC Register II (Address: 0x807h)

Name	R/W	Bit 7	Bit 6	Bit 5	Bit 4	Bit 3	Bit 2	Bit 1	Bit 0
RC OSC II	W	WWS_SL9	WWS_SL8	WWS_AC5	WWS_AC4	WWS_AC3	WWS_AC2	WWS_AC1	WWS_AC0
Reset		0	0	0	0	0	0	0	0

WWS_SL [9:0]: 10-bits WWS_SL Timer for TWWS Function (7.8ms ~ 7.99s).
 WWS_SL [9:0] are from address (0x806h) and (0x807h).

WWS_AC [8:0]: 9-bits WWS_AC Timer for TWWS Function (244us ~ 15.6ms).

9.2.9 RC OSC Register III (Address: 0x808h)

Name	R/W	Bit 7	Bit 6	Bit 5	Bit 4	Bit 3	Bit 2	Bit 1	Bit 0
RC OSC III	W	BBCKS1	BBCKS0	--	CRCSW	BLE_ON	RCTS	TSEL	TWWS_E
Reset		0	0	--	--	--	1	0	1

BBCKS [1:0]: Clock select for internal digital block
[00]: F_{SYCK} / 8. **[01]:** F_{SYCK} / 16. **[10]:** F_{SYCK} / 32. **[11]:** F_{SYCK} / 64.
 F_{SYCK} :System clock. Should be set to 8MHz.

CRCSW: CRC select (BLE_ON=0).
[0]: Select CRC-16, CCITT. **[1]:** Select CRC-24 (BLE).

BLE_ON: Bluetooth Low-Energy Mode enable.
[0]: Disable. **[1]:** Enable.

RCTS: Internal / External 32.768k Hz oscillator selection.
[0]: Internal. **[1]:** External.

TSEL: Timer select for TWWS function.

[0]: Use WWS_AC. [1]: Use WWS_SL.

TWWS_E: Enable TWWS function.

[0]: Disable. [1]: Enable.

9.2.10 RC OSC Register IV (Address: 0x809h)

Name	R/W	Bit 7	Bit 6	Bit 5	Bit 4	Bit 3	Bit 2	Bit 1	Bit 0
RC OSC IV	W	RCOT2	RCOT1	RCOT0	WCKSEL1	WCKSEL0	MVS1	MVS0	ENCAL
	R	NUMLH11	NUMLH10	NUMLH9	NUMLH8	--	RCOC9	RCOC8	ENCAL
Reset		--	--	--	0	0	0	0	0

RCOT[2:0]: RCOSC current select for RC oscillator calibration.

WSEL [1:0]: Clock select for internal RC oscillator Calibration

[00]: 16 MHz

[01]: 8 MHz

[10]: 4 MHz

[11]: 2MHz

ENCAL: WOR calibration enable.

[0]: Disable [1]: Enable.

RCOC [9:0]: WOR Calibration value.

NUMLH[11:0]: WOR calibration latch number.

9.2.11 RC OSC Register V (Address: 0x80Ah)

Name	R/W	Bit 7	Bit 6	Bit 5	Bit 4	Bit 3	Bit 2	Bit 1	Bit 0
RC OSC V	W	MRCT9	MRCT8	--	--	--	TMRE	MAN	MCALS
	R	NUMLH7	NUMLH6	NUMLH5	NUMLH4	NUMLH3	NUMLH2	NUMLH1	NUMLH0
Reset		0	0	--	--	--	--	0	0

MRCT[9:0]: Manual RC-OSC calibration value setting.

MAN: Enable Manual RC-OSC Calibration.

[0]: Auto [1]: Manual.

TMRE: RC-oscillator enable.

[0]: Disable. [1]: Enable.

MCALS: Enable Continuous RC-OSC Calibration.

[0]: Continuous mode. [1]: Single mode.

NUMLH[11:0]: RC-OSC calibration latch number.

9.2.12 RC OSC Register VI (Address: 0x80Bh)

Name	R/W	Bit 7	Bit 6	Bit 5	Bit 4	Bit 3	Bit 2	Bit 1	Bit 0
RC OSC VI	W	MRCT7	MRCT6	MRCT5	MRCT4	MRCT3	MRCT2	MRCT1	MRCT0
	R	RCOC7	RCOC6	RCOC5	RCOC4	RCOC3	RCOC2	RCOC1	RCOC0
Reset		0	0	0	0	0	0	0	0

MRCT [9:0]: Manual RC-OSC calibration value setting.

RCOC [9:0]: RC-OSC calibration value.

9.2.13 RC OSC Register VII (Address: 0x80Ch)

Name	R/W	Bit 7	Bit 6	Bit 5	Bit 4	Bit 3	Bit 2	Bit 1	Bit 0
RCOSC7	W	--	--	--	--	TGNUM11	TGNUM10	TGNUM9	TGNUM8
Reset		--	--	--	--	0	0	0	0

TGNUM[11:0]: Target Number for RC OSC Calibration.

9.2.14 RC OSC Register VIII (Address: 0x80Dh)

Name	R/W	Bit 7	Bit 6	Bit 5	Bit 4	Bit 3	Bit 2	Bit 1	Bit 0
RCOSC8	W	TGNUM7	TGNUM6	TGNUM5	TGNUM4	TGNUM3	TGNUM2	TGNUM1	TGNUM0
Reset		0	0	0	0	0	0	0	0

TGNUM[11:0]: Target Number for RC OSC Calibration.

9.2.15 CKO Pin Control Register (Address: 0x80Eh)

Name	R/W	Bit 7	Bit 6	Bit 5	Bit 4	Bit 3	Bit 2	Bit 1	Bit 0
CKO Pin Control	W	ECKOE	CKOS3	CKOS2	CKOS1	CKOS0	CKOI	WAKEBBIE	INTT1IE
Reset		1	0	1	1	1	0	--	--

ECKOE: External Clock Output Enable for CKOS [3:0]= [0100] ~ [0111].
 [0]: Disable. [1]: Enable.

CKOS[3:0]: CKO pin output select.

[0000]: DCK (TX data clock).

[0001]: RCK (RX recovery clock).

[0010]: FPF (FIFO pointer flag).

[0011]: EOP, EOVCB, EOFBC, EOADC, EOVCB, OKADC, RSSC_OK (Internal usage only).

[0100]: External clock output = F_{SYCK} .

[0101]: External clock output / 2 = $F_{SYCK} / 2$.

[0110]: External clock output / 4 = $F_{SYCK} / 4$.

[0111]: External clock output / 8 = $F_{SYCK} / 8$.

[1000]: WCK (4KHz)

[1001]: PF8M (8MHz)

[1010]: TMRCK (32KHz)

[1011]: SYCK (8MHz)

[1100]: TMRCK_OVF (Timer clock)

CKOI: CKO pin output signal invert.

[0]: Non-inverted output. [1]: Inverted output.

WAKEBBIE: Wake BB interrupt enable.

[0]: Disable. [1]: Enable.

INTT1IE: ARCWTR interrupt enable.

[0]: Disable. [1]: Enable.

9.2.16 GIO1 Pin Control Register I (Address: 0x80Fh)

Name	R/W	Bit 7	Bit 6	Bit 5	Bit 4	Bit 3	Bit 2	Bit 1	Bit 0
GIO1 Pin I	W	VGC1	VGC0	GIO1S3	GIO1S2	GIO1S1	GIO1S0	GIO1I	--
Reset		0	0	0	0	0	0	0	--

GIO1S [3:0]: GIO1 pin function select.

GIO1S [3:0]	TX state	RX state
[0000]	WTR (Wait until TX or RX finished)	
[0001]	EOAC (end of access code)	FSYNC (frame sync)
[0010]	TMEO or TMDEO (TX modulation enable)	CD (carrier detect)

[0011]	Preamble Detect Output (PMDO)
[0100]	MCU wakeup signal (TWWS)
[0101]	In phase demodulator input (DMII)
[0110]	Reserved
[0111]	TRXD In/Out (Direct mode)
[1000]	RXD (Direct mode)
[1001]	TXD (Direct mode)
[1010]	In phase demodulator external input (EXDI0)
[1011]	External FSYNC input in RX direct mode
[1100]	INC
[1101]	PDN_RX
[1110]	INT5
[1111]	Reserved

GIO1I: GIO1 pin output signal invert.

[0]: Non-inverted output. [1]: Inverted output.

9.2.17 GIO2 Pin Control Register II (Address: 0x810h)

Name	R/W	Bit 7	Bit 6	Bit 5	Bit 4	Bit 3	Bit 2	Bit 1	Bit 0
GIO2 Pin Control II	W	HBW	WWS_AC 8	GIO2S3	GIO2S2	GIO2S1	GIO2S0	GIO2I	--
Reset		0	--	0	1	0	0	0	--

WWS_AC8: See 9.2.8

HBW: IF bandwidth setting.

BWS	HBW	IF(Hz)	BW
1	1	2000	1200
1	0	2000	2400
0	1	1000	1200
0	0	1000	1200

GIO2S [3:0]: GIO2 pin function select.

GIO2S	TX state	RX state
[0000]	ARCWTR (Wait until TX or RX finished)	
[0001]	EOAC (end of access code)	FSYNC (frame sync)
[0010]	TMEO or TMDEO(TX modulation enable)	CD (carrier detect)
[0011]	Preamble Detect Output (PMDO)	
[0100]	MCU wakeup signal (TWWS)	
[0101]	Quadrature phase demodulator input (DMIQ)	
[0110]	Reserved	
[0111]	TRXD In/Out (Direct mode)	
[1000]	RXD (Direct mode)	
[1001]	TXD (Direct mode)	
[1010]	Quadrature phase demodulator external input (EXDI1)	
[1011]	External FSYNC input in RX direct mode	
[1100]	DEC	
[1101]	PDN_TX	
[1110]	Reserved	
[1111]	Reserved	

GIO2I: GIO2 pin output signal invert.

[0]: Non-inverted output. [1]: Inverted output.

9.2.18 Clock Register (Address: 0x811h)

Name	R/W	Bit 7	Bit 6	Bit 5	Bit 4	Bit 3	Bit 2	Bit 1	Bit 0
Clock	R/W	GRC3	GRC2	GRC1	GRC0	IDREV	CSC	CGS	XS
Reset		1	1	1	1	0	0	1	1

GRC [3:0]: Clock generation reference counter.

GRC is used to get 2 MHz Clock Generator Reference (F_{CGR}) for internal usage.

Clock generation reference = $F_{CSCK} / (GRC+1)$. Maximum divide ratio is 16.

F_{CSCK} is A8105's master clock.

IDREV: ID reverse enable.

[0]: Disable. [1]: Enable.

CSC: system clock F_{SYCK} divider select.

[0]: F_{CSCK} . [1]: $F_{CSCK} / 2$.

CGS: Clock generator enable.

[0]: Disable. [1]: Enable. CGS shall be set to [1].

XS: Crystal oscillator select.

[0]: Use external clock. [1]: Use external crystal.

Master clock frequency	CGS = 0	CGS = 1
BWS = 0	Crystal frequency	32 MHz
BWS = 1	crystal frequency	64 MHz

9.2.19 Data Rate Register (Address: 0x812h)

Name	R/W	Bit 7	Bit 6	Bit 5	Bit 4	Bit 3	Bit 2	Bit 1	Bit 0
Data Rate	R/W	SDR7	SDR6	SDR5	SDR4	SDR3	SDR2	SDR1	SDR0
Reset		0	0	0	0	0	0	0	0

SDR [7:0]: Data rate division selection.

Data rate = $F_{CSCK} / [32*(SDR [7:0]+1)]$.

9.2.20 PLL Register I (Address: 0x813h)

Name	R/W	Bit 7	Bit 6	Bit 5	Bit 4	Bit 3	Bit 2	Bit 1	Bit 0
PLL I	R/W	CHN7	CHN6	CHN5	CHN4	CHN3	CHN2	CHN1	CHN0
Reset		0	0	0	0	0	0	0	0

CHN [7:0]: LO channel number select.

9.2.21 PLL Register II (Address: 0x814h)

Name	R/W	Bit 7	Bit 6	Bit 5	Bit 4	Bit 3	Bit 2	Bit 1	Bit 0
PLL II	R	DBL	RRC1	RRC0	CHR3	CHR2	CHR1	CHR0	IP8
	W	DBL	RRC1	RRC0	CHR3	CHR2	CHR1	CHR0	BIP8
Reset		0	0	0	0	1	1	1	0

DBL: Crystal frequency doubler selection.

[0]: Disable. $F_{XREF} = F_{XTAL}$. [1]: Enable. $F_{XREF} = 2 * F_{XTAL}$.

RRC [1:0]: RF PLL reference counter setting.

CHR [3:0]: PLL channel step setting.

IP [8:0]: LO frequency integer part value.

IP [8:0] are from address (0x812h) and (0x813h),

9.2.22 PLL Register III (Address: 0x815h)

Name	R/W	Bit 7	Bit 6	Bit 5	Bit 4	Bit 3	Bit 2	Bit 1	Bit 0
PLL III	W	BIP7	BIP6	BIP5	BIP4	BIP3	BIP2	BIP1	BIP0
	R	IP7	IP6	IP5	IP4	IP3	IP2	IP1	IP0
Reset		0	1	0	0	1	0	1	1

IP [8:0]: LO frequency integer part value.

IP [8:0] are from address (0x812h) and (0x813h),

BIP [8:0]: LO base frequency integer part setting.

BIP [8:0] are from address (0x812h) and (0x813h),

9.2.23 PLL Register IV (Address: 0x816h)

Name	R/W	Bit 7	Bit 6	Bit 5	Bit 4	Bit 3	Bit 2	Bit 1	Bit 0
PLL IV	W	FP15	FP14	FP13	FP12	FP11	FP10	FP9	FP8
	R	--/FP15	AC14/FP14	AC13/FP13	AC12/FP12	AC11/FP11	AC10/FP10	AC9/FP9	AC8/FP8
Reset		0	0	0	0	0	0	0	0

FP [15:0]: LO base frequency fractional part setting.

FP [15:0] are from address (0x816h) and (0x817h),

AC [14:0] (Read): Auto Frequency compensation value (if AFC (0x81Ah) =1).

FP [15:0] (Read): LO frequency fractional part setting.

9.2.24 PLL Register V (Address: 0x817h)

Name	R/W	Bit 7	Bit 6	Bit 5	Bit 4	Bit 3	Bit 2	Bit 1	Bit 0
PLL V	W	FP7	FP6	FP5	FP4	FP3	FP2	FP1	FP0
	R	AC7/FP7	AC6/FP6	AC5/FP5	AC4/FP4	AC3/FP3	AC2/FP2	AC1/FP1	AC0/FP0
Reset		0	0	0	0	0	0	1	1

FP [15:0]: LO base frequency fractional part setting.

FP [15:0] are from address (0x814h) and (0x815h),

AC [14:0] (Read): Auto Frequency compensation value (if AFC (0x81Ah) =1).

FP [15:0] (Read): LO frequency fractional part setting.

9.2.25 TX Register I (Address: 0x818h)

Name	R/W	Bit 7	Bit 6	Bit 5	Bit 4	Bit 3	Bit 2	Bit 1	Bit 0
TX I	W	GDR	TMDE	TXDI	TME	FS	FDP2	FDP1	FDP0
Reset		0	1	0	1	0	1	1	0

GDR: Gaussian Filter Over Sampling Rate Select.

[0]: BT= 1. [1]: BT= 0.5

TMDE: TX Modulation Enable for VCO Modulation.

[0]: Disable. [1]: Enable.

TXDI: TX data invert. Recommend TXDI = [0].

[0]: Non-invert. [1]: Invert.

TME: TX modulation enable.

[0]: Disable. [1]: Enable.

FS: Filter select.

The filter shape is gaussian filter.

[0]: disable. [1]: enable.

FDP [2:0]: Frequency deviation power setting. Refer to control register (15h).

9.2.26 TX Register II (Address: 0x819h)

Name	R/W	Bit 7	Bit 6	Bit 5	Bit 4	Bit 3	Bit 2	Bit 1	Bit 0
TX II	W	FD7	FD6	FD5	FD4	FD3	FD2	FD1	FD0
Reset		0	0	1	0	1	1	1	1

FD [7:0]: Frequency deviation setting.

$$F_{DEV} = F_{PFD} / 2^{**16} * FD * 2^{** (FDP-1)}$$

Where $F_{PFD} = F_{XTAL} * (DBL+1) / (RRC [1:0]+1)$, PLL comparison frequency.

9.2.27 Delay Register I (Address: 0x81Ah)

Name	R/W	Bit 7	Bit 6	Bit 5	Bit 4	Bit 3	Bit 2	Bit 1	Bit 0
Delay	W	DPR2	DPR1	DPR0	TDL1	TDL0	PDL2	PDL1	PDL0
Reset		0	0	0	1	0	0	1	0

DPR [2:0]: Delay scaling setting.

Recommend DPR = [000].

TDL [1:0]: Delay for TX data out after PDN_TX enable.

Delay = 20 * (TDL [1:0]+1) * (DPR [2:0]+1) + (TX_5DLY [4:0]+1) us.

PDL [2:0]: Delay for TX settling.

Delay = 20 * (PDL [2:0]+1) * (DPR [2:0]+1) us.

9.2.28 Delay Register II (Address: 0x81Bh)

Name	R/W	Bit 7	Bit 6	Bit 5	Bit 4	Bit 3	Bit 2	Bit 1	Bit 0
Delay	W	WSEL2	WSEL1	WSEL0	AGC_D1	AGC_D0	RS_DLY2	RS_DLY1	RS_DLY0
Reset		0	1	0	0	0	0	0	1

WSEL[2:0]: XTAL settling delay setting (200us ~ 2.5ms). Recommend WSEL = [010].

[000]: 200us. [001]: 400us. [010]: 600us. [011]: 800us.

[100]: 1ms. [101]: 1.5ms. [110]: 2ms. [111]: 2.5ms.

AGC_D [1:0]: RSSI calibration switching time (10us ~ 40us). Recommend AGC_D = [00].

[00]: 10us. [01]: 20us. [10]: 30us. [11]: 40us.

RS_DLY [2:0]: RSSI measurement delay (10us ~ 80us). Recommend RS_DLY = [001].

[000]: 10us. [001]: 20us. [010]: 30us. [011]: 40us.

[100]: 50us. [101]: 60us. [110]: 70us. [111]: 80us.

9.2.29 RX Register (Address: 0x81Ch)

Name	R/W	Bit 7	Bit 6	Bit 5	Bit 4	Bit 3	Bit 2	Bit 1	Bit 0
RX	W	MSCRC	RXSM1	RXSM0	AFC	RXDI	DMG	BWS	ULS
Reset		0	1	0	0	0	0	1	0

MSCRC: Mask CRC (CRC Data Filtering Enable).

[0]: Disable. [1]: Enable.

RXSM [1:0]: Reserved for internal usage only. Shall be set to [10].

AFC: Auto Frequency compensation select.

[0]: Manual compensation. [1]: Auto compensation.

RXDI: RX data output invert. Recommend RXDI = [0].
 [0]: Non-inverted output. [1]: Inverted output.

DMG: Reserved for internal usage only. Shall be set to [0].

BWS: IF Bandwidth selection.
HBW: IF bandwidth setting.

BWS	HBW	IF(Hz)	BW
1	1	2000	1200
1	0	2000	2400
0	1	1000	1200
0	0	1000	1200

ULS: RX Up/Low side band select.
 [0]: Up side band, [1]: Low side band.

9.2.30 RX Gain Register I (Address: 0x81Dh)

Name	R/W	Bit 7	Bit 6	Bit 5	Bit 4	Bit 3	Bit 2	Bit 1	Bit 0
RX Gain I	W	AGCE	MIC	IGC1	IGC0	MGC1	MGC0	LGC1	LGC0
	R	ADC8	MICR	IGCR1	IGCR0	MGCR1	MGCR0	LGCR1	LGCR0
Reset		0	1	1	1	1	1	1	1

AGCE: Auto Front end Gain Control Select.
 [0]: Disable. [1]: Enable.

IGC [1:0]: IFA Attenuation Select.
 [00]: 0dB. [01]: 6dB. [10]: 12dB. [11]: 18dB.

MGC [1:0]: Mixer Gain Attenuation select.
 [00]: 0dB. [01]: 6dB. [10]: 12dB. [11]: 18dB.

LGC [1:0]: LNA Gain Attenuation select.
 [00]: 6dB. [01]: 12dB. [10]: 18dB. [11]: 24dB.

9.2.31 RX Gain Register II (Address: 0x81Eh)

Name	R/W	Bit 7	Bit 6	Bit 5	Bit 4	Bit 3	Bit 2	Bit 1	Bit 0
RX Gain II	W	PKIS1	PKIS0	PKT1	PKT0	DCH1	DCH0	RSAGC1	RSAGC0
		--	--	--	--	--	--	VT1	VT0
Reset		0	0	0	1	0	0	0	0

PKIS[1:0]: AGC Peak Detect Current Select. Recommend PKIS[1:0] = [00].

PKT[1:0]: VCO Peak Detect Current Select. Recommend PKT [1:0] = [01].

DCH [1:0]: AGC Hold setting.
 [00]: Hold by Preamble OK.
 [01]: Hold by SYNC.
 [10]: No Hold.
 [11]: No Hold.

VT[1:0]: AGC comparator output.

RH [7:0]: Reserved for internal usage only.

RSAGC [1:0]: AGC clock select.
 [00]: IF/4

[01]: IF/2
 [10]: IF
 [11]: 2*IF

Where IF is 1Mhz for BWS=0, and 2Mhz for BWS=1.

9.2.32 RX Gain Register III (Address: 0x81Fh)

Name	R/W	Bit 7	Bit 6	Bit 5	Bit 4	Bit 3	Bit 2	Bit 1	Bit 0
RX Gain III	W	IFPK	VRSEL	MS	MSCL4	MSCL3	MSCL2	MSCL1	MSCL0
	R	RH7	RH6	RH5	RH4	RH3	RH2	RH1	RH0
Reset		0	0	0	0	0	0	0	0

IFPK: AGC Amplifier Current Select. Recommend IFPK = [0].

VRSEL: ADC reading select.

[0]: Normal ADC. [1]: RSSI ADC (with AGC turn on).

MS: AGC Manual scale select.

[0]: RL-RH(Auto). [1]: MSCL(Manual).

MSCL[4:0]: AGC Manual Scale setting.

RH [7:0]: RSSI Calibration High Threshold.

9.2.33 RX Gain Register IV (Address: 0x820h)

Name	R/W	Bit 7	Bit 6	Bit 5	Bit 4	Bit 3	Bit 2	Bit 1	Bit 0
RX Gain III	W	MXD	CSS	HPLS	MHC1	MHC0	LHC1	LHC0	XADSP
	R	RL7	RL6	RL5	RL4	RL3	RL2	RL1	RL0
Reset		0	0	1	0	1	1	1	0

MXD: Reserved for internal usage only. Shall be set to [0].

CSS: RX demodulation carrier detect select.

[0]: Deselect. [1]: select.

HPLS: High Power LNA Gain Select. Recommend HPLS = [0].

[0]: LGC is set to 6dB when in TX Mode. [1]: LGC is set to LGM[1:0].

MHC [1:0]: Reserved for internal usage only. Shall be set to [10].

LHC [1:0]: Reserved for internal usage only. Shall be set to [10].

XADS: ADC input signal select.

[0]: Convert internal temperature or RSS signal. [1]: Convert external voltage,

RL [7:0]: RSSI Calibration Low Threshold value.

9.2.34 RSSI Threshold Register (Address: 0x821h)

Name	R/W	Bit 7	Bit 6	Bit 5	Bit 4	Bit 3	Bit 2	Bit 1	Bit 0
RSSI Threshold	W	RTH7	RTH6	RTH5	RTH4	RTH3	RTH2	RTH1	RTH0
	R	ADC7	ADC6	ADC5	ADC4	ADC3	ADC2	ADC1	ADC0
Reset		0	0	0	0	0	0	0	0

RTH [7:0]: Carrier detect threshold.

ADC [8:0]: ADC output value of temperature, RSSI or external voltage measurement (read only).

ADC [8:0] are located at address 0x81D and 0x821h.

For normal ADC measurement with VRSEL=0 (in 0x81Fh), which include external voltage, Temp and RSSI with AGC off measurement, ADC [8] is zero. ADC input voltage= 1.2 * ADC [8:0] / 256 V.

9.2.35 ADC Control Register (Address: 0x822h)

Name	R/W	Bit 7	Bit 6	Bit 5	Bit 4	Bit 3	Bit 2	Bit 1	Bit 0
ADC Control	W	RSM1	RSM0	ERSS	FSARS	SYNCS	XADS	RSS	CDM
Reset		0	1	0	1	0	0	1	1

RSM [1:0]: RSSI margin = RTH – RTL. Recommend RSM = [11].
 [00]: 5. [01]: 10. [10]: 15. [11]: 20.

ERSS: end enable for RSSI measurement

[0]: RSSI measurement continues until leave off RX mode.

[1]: RSSI measurement will end when carrier detected and ID code word received.

FSARS: ADC clock select. Recommend FSARS = [0].

[0]: 2MHz. [1]: 4MHz.

SYNCS: Sync word detect select.

[1]: sync word. [0]: preamble

XADS: ADC input signal select.

[0]: Convert internal temperature or RSS signal. [1]: Convert external voltage.

RSS: Temperature/RSSI measurement select.

[0]: Temperature measurement. [1]: RSSI or carrier-detect measurement.

CDM: RSSI measurement mode.

[0]: Single mode. [1]: Continuous mode.

9.2.36 Code Register I (Address: 0x823h)

Name	R/W	Bit 7	Bit 6	Bit 5	Bit 4	Bit 3	Bit 2	Bit 1	Bit 0
Code I	W	XDS	MCS	WHTS	FECS	CRCS	PML2	PML1	PML0
Reset		0	0	0	0	0	0	1	1

XDS: VCO Modulation Data Sampling Clock selection.

[0]: 8x over-sampling Clock. [1]: XCPCCK Clock.

MCS: Manchester Code Enable.

[0]: Disable. [1]: Enable.

WHTS: Data whitening (Data Encryption) select.

[0]: Disable. [1]: Enable.

FECS: FEC select.

[0]: Disable. [1]: Enable.

CRCS: CRC select.

[0]: Disable. [1]: Enable.

PML [2:0]: Preamble length select. Recommend PML= [11].

[000]: 1 byte. [001]: 2 bytes. [010]: 3 bytes. [011]: 4 bytes.

[100]: 5bytes. [101]: 6bytes. [110]: 7bytes. [111]: 8bytes

9.2.37 Code Register II (Address: 0x824h)

Name	R/W	Bit 7	Bit 6	Bit 5	Bit 4	Bit 3	Bit 2	Bit 1	Bit 0
Code II	W	DCL2	DCL1	DCL0	ETH2	ETH1	ETH0	PMD1	PMD0
Reset		1	1	1	0	0	1	1	1

DCL [2:0]: Demodulator DC estimation average mode. Refer to DCM (0x82Bh) for details.

DCL [2]: payload average mode.

[0]: 128 bits average. [1]: 256 bits average.

DCL [1]: For average and hold mode.

[0]: 32 bits average. [1]: 64 bits average.

DCL [0]: Preamble detection delay. Count from preamble detected signal. Recommend DCL0 = [1].

[0]: 4 bits for DCL1=0, 8 bits for DCL1=1. [1]: 8 bits for DCL1=0, 16 bits for DCL1=1.

ETH [2:0]: ID code error tolerance. Recommend ETH = [01].

[000]~[111]: 0~7 bit.

PMD [1:0]: Preamble pattern detection length. Recommend PMD = [10].

[00]: 0bit. [01]: 4bits. [10]: 8bits. [11]: 16bits.

9.2.38 Code Register III (Address: 0x825h)

Name	R/W	Bit 7	Bit 6	Bit 5	Bit 4	Bit 3	Bit 2	Bit 1	Bit 0
Code III	W	IDL	WS6	WS5	WS4	WS3	WS2	WS1	WS0
Reset		1	0	1	0	1	0	1	0

IDL: ID code length select. Recommend IDL= [1].

[0]: 2 bytes. [1]: 4 bytes.

WS [6:0]: Data Whitening seed setting (data encryption key).

9.2.39 IF Calibration Register I (Address: 0x826h)

Name	R/W	Bit 7	Bit 6	Bit 5	Bit 4	Bit 3	Bit 2	Bit 1	Bit 0
IF Calibration I	W	RNUM0_2	RNUM0_1	RNUM0_0	MFBS	MFB3	MFB2	MFB1	MFB0
	R	--	--	--	FBCF	FB3	FB2	FB1	FB0
Reset		1	0	0	0	0	1	1	0

RNUM0[2:0]: sync word clock recovery manual setting.

MFBS: IF filter calibration value select. Recommend MFBS = [0].

[0]: Auto calibration value. [1]: Manual calibration value.

MFB [3:0]: IF filter manual calibration value.

FBCF: IF filter auto calibration flag.

[0]: Pass. [1]: Fail.

FB [3:0]: IF filter calibration value.

MFBS= 0: Auto calibration value (AFB),

MFBS= 1: Manual calibration value (MFB).

9.2.40 IF Calibration Register II (Address: 0x827h)

Name	R/W	Bit 7	Bit 6	Bit 5	Bit 4	Bit 3	Bit 2	Bit 1	Bit 0
IF Calibration II	W	PWORS	TRT2	TRT1	TRT0	MRCKS	RNUM1_2	RNUM1_1	RNUM1_0
	R	--	--	--	FCD4	FCD3	FCD2	FCD1	FCD0
Reset		0	0	1	1	0	0	0	0

PWORS: TX high power setting.

[0]: Disable. [1]: Enable.

TRT [2:0]: TX Ramp down discharge current select. Recommend value=[000]

MRCKS: Preamble detect and sync detect manual setting. [1]: manual

RNUM1[2:0]: sync word clock recovery manual setting.

FCD [4:0]: IF filter calibration deviation from goal.

9.2.41 VCO current Calibration Register (Address: 0x828h)

Name	R/W	Bit 7	Bit 6	Bit 5	Bit 4	Bit 3	Bit 2	Bit 1	Bit 0
VCO current Calibration	W	--	PKS	VCCS	MVCS	VCOC3	VCOC2	VCOC1	VCOC0
	R	TWORF	--	--	FVCC	VCB3	VCB2	VCB1	VCB0
Reset		0	0	0	0	1	0	0	0

PKS: VCO Current Calibration Mode Select. Recommend PKS = [0].

VCCS: Reserved for internal usage only. Shall be set [0].

MVCS: VCO current calibration value select. Recommend MVCS = [0].
 [0]: Auto calibration value. [1]: Manual calibration value.

VCOC [3:0]: VCO current manual calibration value.

TWORF: TWOR interrupt flag.

FVCC: VCO current auto calibration flag.
 [0]: Pass. [1]: Fail.

VCB [3:0]: VCO current calibration value.
 MVCS= 0: Auto calibration value (VCB).
 MVCS= 1: Manual calibration value (VCOC).

9.2.42 VCO Single band Calibration Register I (Address: 0x829h)

Name	R/W	Bit 7	Bit 6	Bit 5	Bit 4	Bit 3	Bit 2	Bit 1	Bit 0
VCO Single band Calibration I	W	DCD1	DCD0	DAGS	PDV	MVBS	MVB2	MVB1	MVB0
	R	--	--	--	--	VBCF	VB2	VB1	VB0
Reset		1	1	0	1	0	1	0	0

DCD [1:0]: VCO Deviation Calibration Delay. Recommend DCD = [01].
 Delay time = PDL (Delay Register I, 0x818h) × (DDC + 1).

DAGS: DAG Calibration Value Select. Recommend DAGS = [0].
 [0]: Auto calibration value. [1]: Manual calibration value.

PDV: Reserved for internal usage only. Shall be set [0].

MVBS: VCO bank calibration value select. Recommend MVBS = [0].
 [0]: Auto calibration value. [1]: Manual calibration value.

MVB [2:0]: VCO band manual calibration value.

VBCF: VCO band auto calibration flag.
 [0]: Pass. [1]: Fail.

VB [2:0]: VCO bank calibration value.
 MVBS= 0: Auto calibration value (AVB).
 MVBS= 1: Manual calibration value (MVB).

9.2.43 VCO Single band Calibration Register II (Address: 0x82Ah)

Name	R/W	Bit 7	Bit 6	Bit 5	Bit 4	Bit 3	Bit 2	Bit 1	Bit 0
------	-----	-------	-------	-------	-------	-------	-------	-------	-------

VCO Single band Calibration II	W	DAMV1	DAMV0	VTH2	VTH1	VTH0	VTL2	VTL1	VTL0
Reset		1	0	1	1	1	0	1	1

DMV [1:0]: Demodulator D/A Voltage Range Select. Recommend DMV = [10].

[00]: 1/32*1.2. [01]: 1/16*1.2. [10]: 1/8*1.2. [11]: 1/4*1.2.

VTH [2:0]: RF AGC upper threshold level setting

[000]: VDD_A – 0.6V. [001]: VDD_A – 0.7V. [010]: VDD_A – 0.8V. [011]: VDD_A – 0.9V

[100]: VDD_A – 1.0V. [101]: VDD_A – 1.1V. [110]: VDD_A – 1.2V. [111]: VDD_A – 1.3V

VDD_A is on chip analog regulator output voltage

VTL [2:0]: RX AGC lower threshold level setting

[000]: 0.1V. [001]: 0.2V. [010]: 0.3V. [011]: 0.4V.

[100]: 0.5V. [101]: 0.6V. [110]: 0.7V. [111]: 0.8V

9.2.44 Battery detect Register (Address: 0x82Bh)

Name	R/W	Bit 7	Bit 6	Bit 5	Bit 4	Bit 3	Bit 2	Bit 1	Bit 0
Battery detect	W	RGS	RGV1	RGV0	PACTL	BVT2	BVT1	BVT0	BDS
	R	--	RGV1	RGV0	BDF	BVT2	BVT1	BVT0	BDS
Reset		0	0	0	0	0	1	1	0

RGS: VDD_D voltage setting in Sleep mode.

[0]: 1.8V. [1]: 1.6V.

RGV [1:0]: VDD_D and VDD_A voltage setting in non-Sleep mode. Recommend RGV = [11].

[00]: 1.9V. [01]: 1.8V. [10]: 1.7V. [11]: 1.6V.

PACTL: Reserved for internal usage only. Shall be set to [0].

BVT [2:0]: Battery voltage detect threshold.

[000]: 1.8V. [001]: 1.9V. [010]: 2.0V. [011]: 2.1V.

[100]: 2.2V. [101]: 2.3V. [110]: 2.4V. [111]: 2.5V.

BDS: Battery detect enable.

[0]: Disable. [1]: Enable. It will be clear after battery detection done.

BDF: Battery detection flag.

[0]: Battery voltage less than threshold. [1]: Battery voltage greater than threshold.

Refer to chapter 19 for details.

9.2.45 TX test Register (Address: 0x82Ch)

Name	R/W	Bit 7	Bit 6	Bit 5	Bit 4	Bit 3	Bit 2	Bit 1	Bit 0
TX test	W	IFBC1	IFBC0	TXCS	PAC1	PAC0	TBG2	TBG1	TBG0
Reset		0	0	0	1	0	1	1	1

RMP [1:0]: PA ramp up timing scale.

Delay scales $2^{(RMP [1:0])}$

TXCS: TX Current Setting.

PAC [1:0]: PA Current Setting.

TBG [2:0]: TX Buffer Setting.

9.2.46 Rx DEM test Register I (Address: 0x82Dh)

Name	R/W	Bit 7	Bit 6	Bit 5	Bit 4	Bit 3	Bit 2	Bit 1	Bit 0
------	-----	-------	-------	-------	-------	-------	-------	-------	-------

Rx DEM test I	W	DMT	DCM1	DCM0	MLP1	MLP0	SLF2	SLF1	SLF0
Reset		0	1	1	0	0	1	0	0

DMT: Reserved for internal usage only. Shall be set to [0].

DCM [1:0]: Demodulator DC estimation mode.

[00]: Fix mode (For testing only). DC level is set by DCV [7:0].

[01]: Preamble hold mode. DC level is preamble average value.

[10]: Average and hold mode. DC level is the average value hold about 8 bit data rate later after preamble is detected.

[11]: Payload average mode (For internal usage). DC level is payload data average.

MLP [1:0]: Reserved for internal usage only. Shall be set to [000].

SLF [2:0]: Reserved for internal usage only. Shall be set to [111].

9.2.47 Rx DEM test Register II (Address: 0x82Eh)

Name	R/W	Bit 7	Bit 6	Bit 5	Bit 4	Bit 3	Bit 2	Bit 1	Bit 0
Rx DEM test II	W	DCV7	DCV6	DCV5	DCV4	DCV3	DCV2	DCV1	DCV0
Reset		1	0	0	0	0	0	0	0

DCV [7:0]: Demodulator fix mode DC value. Recommend DCV = [0x80].

9.2.48 Charge Pump Current Register (Address: 0x82Fh)

Name	R/W	Bit 7	Bit 6	Bit 5	Bit 4	Bit 3	Bit 2	Bit 1	Bit 0
Charge Pump Current	W	CPM3	CPM2	CPM1	CPM0	CPT3	CPT2	CPT1	CPT0
Reset		1	1	1	1	1	1	1	1

CPM [3:0]: Charge Pump Current Setting for VM loop. Recommend CPM = [1111].

Charge pump current = (CPM + 1) / 16 mA.

CPT [3:0]: Charge Pump Current Setting for VT loop. Recommend CPT = [1111].

Charge pump current = (CPT + 1) / 16 mA.

9.2.49 Crystal test Register (Address: 0x830h)

Name	R/W	Bit 7	Bit 6	Bit 5	Bit 4	Bit 3	Bit 2	Bit 1	Bit 0
Crystal test	W	PRS	QDS	QLIM	DBD	XCC1	XCC0	XCP1	XCP0
Reset		0	0	0	0	0	1	0	1

PRS: Limiter amplifier discharge manual select. Recommend PRS = [0].

QDS: VDD_A Quick Discharge Select.

[0]: Disable. **[1]:** Enable.

QLIM: quick charge select for IF limiter amp.

[0]: disable. **[1]:** enable (QLIM fall down delay 10us)

DBD: Reserved for internal usage only. Shall be set to [0].

XCC[1:0]: Crystal current setting. Shall be set to [01].

XCP[1:0]: Crystal regulating couple setting. Shall be set to [01].

9.2.50 PLL test Register (Address: 0x831h)

Name	R/W	Bit 7	Bit 6	Bit 5	Bit 4	Bit 3	Bit 2	Bit 1	Bit 0
PLL test	W	MDEN	PMPE	PRIC1	PRIC0	PRRC1	PRRC0	SDPW	NSDO
Reset		0	1	1	0	1	0	0	0

MDEN : Use for Manual VCO Calibration. Shall be set to [0].

PMPE: Reserved for internal usage only. Shall be set to [1].

PRIC[1:0]: Reserved for internal usage only. Shall be set to [01].

PRRC[1:0]: Reserved for internal usage only. Shall be set to [01].

SDPW: Reserved for internal usage only. Shall be set to [0].

NSDO: Reserved for internal usage only. Shall be set to [1].

9.2.51 VCO test Register I (Address: 0x832h)

Name	R/W	Bit 7	Bit 6	Bit 5	Bit 4	Bit 3	Bit 2	Bit 1	Bit 0
VCO test I	W	DEVGD2	DEVGD1	DEVGD0	TLB1	TLB0	RLB1	RLB0	MGS
Reset		0	0	0	1	1	0	1	0

DEVGD [2:0]: Sigma Delta Modulator Data Delay Setting. Recommend DEVGD = [000].

TLB [1:0]: Reserved for internal usage only. Shall be set to [11].

RLB [1:0]: Reserved for internal usage only. Shall be set to [00].

MGS: IGC Manual setting select.

[0]: Auto. [1]: Manual.

9.2.52 VCO test Register II (Address: 0x833h)

Name	R/W	Bit 7	Bit 6	Bit 5	Bit 4	Bit 3	Bit 2	Bit 1	Bit 0
VCO test II	W	CHD3	CHD2	CHD1	CHD0	RFT3	RFT2	RFT1	RFT0
Reset		0	1	0	1	0	0	0	0

CHD [3:0]: Channel Frequency Offset for Deviation Calibration.

Offset channel number = +/- (CHD + 1).

RFT [3:0]: RF analog pin configuration for testing. Recommend RFT= [0000].

9.2.53 IFAT Register (Address: 0x834h)

Name	R/W	Bit 7	Bit 6	Bit 5	Bit 4	Bit 3	Bit 2	Bit 1	Bit 0
VCO test II	W	MPDT5	MPDT4	MPDT3	MPDT2	MPDT1	MPDT0	--	LIMC
Reset		1	0	0	0	0	0	--	1

MPDT[5:0]: TX ramp up/down scale select.

LIMC: Reserved for internal usage only. Shall be set to [1].

9.2.54 RFT Test Register I (Address: 0x835h)

Name	R/W	Bit 7	Bit 6	Bit 5	Bit 4	Bit 3	Bit 2	Bit 1	Bit 0
RFT1	W	ASMV2	ASMV1	ASMV0	SDMS	OLM	CPCS	CPH	CPS
Reset		0	0	0	1	0	1	1	1

ASMV [2:0]: TX Ramp up/Ramp down Timing Select.

[000]: 4us, [001]: 8us. [010]: 12us. [011]: 16us. [100]: 20us, [101]: 24us. [110]: 28us. [111]: 32us.

SDMS: Reserved for internal usage only. Shall be set to [1].

OLM : Open Loop Modulation Enable. Shall be set to [0].

[0]: Disable. [1]: Enable.

CPCS: Charge Pump Current Select. Shall be set to [0].

[0]: Use CPM for TX, CPT for RX.

[1]: Use CPTX for TX, CPRX for RX.

CPH: Charge Pump High Current. Shall be set to [0].

[0]: Normal. [1]: High.

CPCS: Charge Pump Current Select. Shall be set to [0].

[0]: Use CPM for TX, CPT for RX.

[1]: Use CPTX for TX, CPRX for RX.

9.2.55 RFT Test Register II (Address: 0x836h)

Name	R/W	Bit 7	Bit 6	Bit 5	Bit 4	Bit 3	Bit 2	Bit 1	Bit 0
RFT2	W	--	CRS3	CRS2	CRS1	CRS0	SRS2	SRS1	SRS0
	R	--	CRSR3	CRSR2	CRSR1	CRSR0	SRSR2	SRSR1	SRSR0
Reset		--	0	1	0	0	1	0	0

CRS [2:0]: RSSI voltage offset fine trim setting.

SRS [2:0]: RSSI voltage curve slope fine time setting.

9.2.56 RFT Test Register III (Address: 0x837h)

Name	R/W	Bit 7	Bit 6	Bit 5	Bit 4	Bit 3	Bit 2	Bit 1	Bit 0
RFT3	W	--	STMP	STM5	STM4	STM3	STM2	STM1	STM0
	R	--	--	STMR5	STMR4	STMR3	STMR2	STMR1	STMR0
Reset		0	0	1	0	0	0	0	0

STMP: Temp voltage ADC reading select.

[0]: 1 scale / degree C. [1]: 2 scale/degree C.

STM [5:0]: ADC voltage fine trim setting.

9.2.57 RFT Test Register IV (Address: 0x838h)

Name	R/W	Bit 7	Bit 6	Bit 5	Bit 4	Bit 3	Bit 2	Bit 1	Bit 0
RFT4	W	--	DVI1	DVI0	FBG4	FBG3	FBG2	FBG1	FBG0
	R	--	--	--	FBGR4	FBGR3	FBGR2	FBGR1	FBGR0
Reset		--	0	0	1	0	0	0	0

DVI[1:0]: Reserved for internal usage

FBG[4:0]: Bandgap voltage SPI fine trim setting.

9.2.58 RFT Test Register V (Address: 0x839h)

Name	R/W	Bit 7	Bit 6	Bit 5	Bit 4	Bit 3	Bit 2	Bit 1	Bit 0
RFT5	W	FGC1	FGC0	CTR5	CTR4	CTR3	CTR2	CTR1	CTR0
	R	FGCR1	FGCR0	CTRR5	CTRR4	CTRR3	CTRR2	CTRR1	CTRR0
Reset		1	1	1	0	0	0	0	0

FGC[1:0]: BPF fine gain control.

CTR [5:0]: ADC voltage SPI fine trim setting.

9.2.59 Channel Index Register (Address: 0x83Ah)

Name	R/W	Bit 7	Bit 6	Bit 5	Bit 4	Bit 3	Bit 2	Bit 1	Bit 0
------	-----	-------	-------	-------	-------	-------	-------	-------	-------

Channel Index	W	--	--	CHIDX5	CHIDX4	CHIDX3	CHIDX2	CHIDX1	CHIDX0
Reset		--	0	1	0	0	1	0	1

CHIDX[5:0]: Whitening seed setting for BLE mode(BLE_ON=1).

9.2.60 CRC Register 1 (Address: 0x83Bh)

Name	R/W	Bit 7	Bit 6	Bit 5	Bit 4	Bit 3	Bit 2	Bit 1	Bit 0
CRC1	W	CRCINIT23	CRCINIT22	CRCINIT21	CRCINIT20	CRCINIT19	CRCINIT18	CRCINIT17	CRCINIT16
Reset		0	1	0	1	0	1	0	1

CRCINIT[23:0]: CRC initial value for TX CRC-24bits encoder.

9.2.61 CRC Register 2 (Address: 0x83Ch)

Name	R/W	Bit 7	Bit 6	Bit 5	Bit 4	Bit 3	Bit 2	Bit 1	Bit 0
CRC2	W	CRCINIT15	CRCINIT14	CRCINIT13	CRCINIT12	CRCINIT11	CRCINIT10	CRCINIT9	CRCINIT8
Reset		0	1	0	1	0	1	0	1

9.2.62 CRC Register 3 (Address: 0x83Dh)

Name	R/W	Bit 7	Bit 6	Bit 5	Bit 4	Bit 3	Bit 2	Bit 1	Bit 0
CRC3	W	CRCINIT7	CRCINIT6	CRCINIT5	CRCINIT4	CRCINIT3	CRCINIT2	CRCINIT1	CRCINIT0
Reset		0	1	0	1	0	1	0	1

9.2.63 CRC Register 4 (Address: 0x83Eh)

Name	R/W	Bit 7	Bit 6	Bit 5	Bit 4	Bit 3	Bit 2	Bit 1	Bit 0
CRC4	W	CRCINR23	CRCINR22	CRCINR21	CRCINR20	CRCINR19	CRCINR18	CRCINR17	CRCINR16
Reset		0	1	0	1	0	1	0	1

CRCINR[23:0]: CRC initial value for RX CRC-24bits decoder.

9.2.64 CRC Register 5 (Address: 0x83Fh)

Name	R/W	Bit 7	Bit 6	Bit 5	Bit 4	Bit 3	Bit 2	Bit 1	Bit 0
CRC5	W	CRCINR15	CRCINR14	CRCINR13	CRCINR12	CRCINR11	CRCINR10	CRCINR9	CRCINR8
Reset		0	1	0	1	0	1	0	1

9.2.65 CRC Register 6 (Address: 0x840h)

Name	R/W	Bit 7	Bit 6	Bit 5	Bit 4	Bit 3	Bit 2	Bit 1	Bit 0
CRC6	W	CRCINR7	CRCINR6	CRCINR5	CRCINR4	CRCINR3	CRCINR2	CRCINR1	CRCINR0
Reset		0	1	0	1	0	1	0	1

9.2.66 VCO Single band Calibration Register I (Address: 0x841h)

Name	R/W	Bit 7	Bit 6	Bit 5	Bit 4	Bit 3	Bit 2	Bit 1	Bit 0
VCO Single band Calibration III	W	DAGM7	DAGM6	DAGM5	DAGM4	DAGM3	DAGM2	DAGM1	DAGM0
	R	ADAG7	ADAG6	ADAG5	ADAG4	ADAG3	ADAG2	ADAG1	ADAG0
Reset		1	0	0	0	0	0	0	0

DAGM [7:0]: DAG Manual Setting Value. Recommend DAGM = [0x80].

ADAG [7:0]: Auto DAG Calibration Value.

9.2.67 VCO deviation Calibration Register I (Address: 0x842h)

Name	R/W	Bit 7	Bit 6	Bit 5	Bit 4	Bit 3	Bit 2	Bit 1	Bit 0
VCO Deviation I	W	DEVS3	DEVS2	DEVS1	DEVS0	DAMR_M	VMTE_M	VMS_M	MSEL
	R	DEVA7	DEVA6	DEVA5	DEVA4	DEVA3	DEVA2	DEVA1	DEVA0
Reset		0	1	1	1	0	0	0	0

DEVS [3:0]: Deviation Output Scaling. Recommend DEVS = [0011].

DAMR_M: DAMR Manual Enable. Recommend DAMR_M = [0].
 [0]: Disable. [1]: Enable.

VMTE_M: VMT Manual Enable. Recommend VMTE_M = [0].
 [0]: Disable. [1]: Enable.

VMS_M: VM Manual Enable. Recommend VMS_M = [0].
 [0]: Disable. [1]: Enable.

MSEL: VMS, VMTE and DAMR control select. Recommend MSEL = [0].
 [0]: Auto control. [1]: Manual control.

DEVA [7:0]: Deviation Output Value.
 MVDS (0x841h)= 0: Auto calibration value ((DEVC / 8) × (DEVS + 1)),
 MVDS (0x841h)= 1: Manual calibration value (DEVM [6:0]).

9.2.68 VCO deviation Calibration Register II (Address: 0x843h)

Name	R/W	Bit 7	Bit 6	Bit 5	Bit 4	Bit 3	Bit 2	Bit 1	Bit 0
VCO Deviation II	W	MVDS	DEVM6	DEVM5	DEVM4	DEVM3	DEVM2	DEVM1	DEVM0
	R	ADEV7	ADEV6	ADEV5	ADEV4	ADEV3	ADEV2	ADEV1	ADEV0
Reset		0	0	1	0	1	0	0	0

MVDS: VCO Deviation Calibration Select. Recommend MVDS = [0].
 [0]: Auto calibration value. [1]: Manual calibration value.

DEVM [6:0]: VCO Deviation Manual Calibration Value.

ADEV [7:0]: VCO Deviation Auto Calibration Value.

9.2.69 VCO deviation Calibration Register III (Address: 0x844h)

Name	R/W	Bit 7	Bit 6	Bit 5	Bit 4	Bit 3	Bit 2	Bit 1	Bit 0
VCO Deviation III	W/R	VMG7	VMG6	VMG5	VMG4	VMG3	VMG2	VMG1	VMG0
Reset		1	0	0	0	0	0	0	0

VMG [7:0]: VM Center Value for Deviation Calibration. Recommend VMG [7:0] = [0x80].

9.2.70 ADC Control Register (Address: 0x845h)

Name	R/W	Bit 7	Bit 6	Bit 5	Bit 4	Bit 3	Bit 2	Bit 1	Bit 0
ADC	W	AVSEL1	AVSEL0	MVSEL1	MVSEL0	RADC	FPS2	FPS1	FPS0
Reset		1	0	1	0	0	0	0	0

AVSEL [1:0]: ADC average times (for Carrier / temperature sensor / external ADC). Recommend AVSEL = [10].
 [00]: No average. [01]: Average 2 times. [10]: Average 4 times. [11]: Average 8 times.

MVSEL [1:0]: ADC average times (for VCO calibration and RSSI). Recommend MVSEL = [01].
 [00]: Average 8 times. [01]: Average 16 times. [10]: Average 32 times. [11]: Average 64 times.

RADC: ADC read out average mode.

[0]: 1, 2, 4, 8 average mode. The average number is according to the setting of AVSEL in RX Gain Register (IV).

[1]: 8, 16, 32, 64 average mode. The average number is according to the setting of MVSEL in RX Gain Register (IV)

FPS[2:0]: Gaussian filter BT setting.

GDR=0.

FPS[2:0]	7	6	5	4	3	2	1	0
BT	1.4	1.3	1.2	1.1	0.75	0.7	0.65	0.6

GDR=1.

FPS[2:0]	7	6	5	4	3	2	1	0
BT	0.7	0.65	0.6	0.55	X	X	X	X

9.2.71 WOT Register (Address: 0x846h)

Name	R/W	Bit 7	Bit 6	Bit 5	Bit 4	Bit 3	Bit 2	Bit 1	Bit 0
WOT	W	--	SPSS	WMODE	WN1	WN0			
Reset		0	0	0	0	0	--	--	--

SPSS: Mode back select in WOT mode.

[0]: Standby mode. [1]: PLL mode.

WMODE: Wakeup mode select.

[0]: WOR [1]: WOT

WN[1:0]: WOT Wake up times.

9.2.72 Channel Group Register I (Address: 0x847h)

Name	R/W	Bit 7	Bit 6	Bit 5	Bit 4	Bit 3	Bit 2	Bit 1	Bit 0
CHGL	R/W	CHGL7	CHGL6	CHGL5	CHGL4	CHGL3	CHGL2	CHGL1	CHGL0
Reset		0	0	1	0	1	0	0	0

CHGL [7:0]: PLL channel group low boundary setting.

9.2.73 Channel Group Register II (Address: 0x848h)

Name	R/W	Bit 7	Bit 6	Bit 5	Bit 4	Bit 3	Bit 2	Bit 1	Bit 0
CHGH	R/W	CHGH7	CHGH6	CHGH5	CHGH4	CHGH3	CHGH2	CHGH1	CHGH0
Reset		0	1	0	1	0	0	0	0

CHGH [7:0]: PLL channel group high boundary setting.

PLL frequency is divided into 3 groups:

	Channel
Group1	0 ~ CHGL-1
Group2	CHGL ~ CHGH-1
Group3	CHGH ~ 255

Note: Each group needs its own VCO current, bank and deviation calibration. Use the same calibration value for the frequency in the same group.

9.2.74 Charge Pump Current Register II (Address: 0x849h)

Name	R/W	Bit 7	Bit 6	Bit 5	Bit 4	Bit 3	Bit 2	Bit 1	Bit 0
CPC II	W	CPTX3	CPTX2	CPTX1	CPTX0	CPRX3	CPRX2	CPRX1	CPRX0
Reset		0	0	1	0	0	0	1	0

CPTX [3:0]: Charge Pump Current Setting for TX mode. Recommend CPTX = [0010].

Charge pump current = (CPTX + 1) / 16 mA.

CPRX [3:0]: Charge Pump Current Setting for RX mode. Recommend CPRX = [0010].

Charge pump current = (CPRX + 1) / 16 mA.

9.2.75 VCO Modulation Delay Register (Address: 0x84Ah)

Name	R/W	Bit 7	Bit 6	Bit 5	Bit 4	Bit 3	Bit 2	Bit 1	Bit 0
VCO Delay	W	--	INTPRC	DEVFD2	DEVFD1	DEVFD0	DEVD2	DEVD1	DEVD0
Reset		0	0	1	0	1	0	0	0

INTPRC: Internal PLL loop filter resistor and capacitor select.

[0]: disable. [1]: enable

DEVFD [2:0]: VCO Modulation Data Delay by 8x over-sampling Clock. Recommend DEVFD = [101].

DEVD [2:0]: VCO Modulation Data Delay by XCPCCK Clock. Recommend DEVD = [000].

9.2.76 Internal Capacitance Register (Address: 0x84Bh)

Name	R/W	Bit 7	Bit 6	Bit 5	Bit 4	Bit 3	Bit 2	Bit 1	Bit 0
INTC	W	VRPL1	VRPL0	VCOSC5	VCOSC4	VCOSC3	VCOSC2	VCOSC1	VCOSC0
Reset		0	0	0	1	0	1	0	0

VRPL [1:0]: internal PLL loop filter resistor value select.

[00]: 500 ohm. [01]: 666 ohm. [10]: 1 K ohm. [11]: 2K ohm.

VCOSC[5:0]: Reserved for internal usage

9.2.77 RX Detection Register (Address: 0x84Ch)

Name	R/W	Bit 7	Bit 6	Bit 5	Bit 4	Bit 3	Bit 2	Bit 1	Bit 0
DET	W	DC_SEL	RXDCS	PREDN2	PREDN1	PREDN0	PREUP2	PREUP1	PREUP0
	R	DCOUT[7:0]							
Reset		0	0	1	0	0	0	1	0

DC_SEL: Initial DC value select when sync word ok. [0]: DC set by last pattern DC

[1]: DC set by 0x82Eh DC value.

RXDCS: RX dc average clock setting. Recommended RXDCS=[0]

PREDN[2:0]: Preamble detect low threshold setting.

PREUP[2:0]: Preamble detect high threshold setting.

DCOUT [7:0]: Read demodulator DC value.

9.2.78 BLE Header Register 0 (Address: 0x84Dh)

Name	R/W	Bit 7	Bit 6	Bit 5	Bit 4	Bit 3	Bit 2	Bit 1	Bit 0
HEADER0	W	TXHDR15	TXHDR14	TXHDR13	TXHDR12	TXHDR11	TXHDR10	TXHDR9	TXHDR8
	R	RXHDR15	RXHDR14	RXHDR13	RXHDR12	RXHDR11	RXHDR10	RXHDR9	RXHDR8
Reset		0	0	0	0	0	0	0	0

TXHDR[15:0]: TX header setting for BLE mode.

RXHDR[15:0]: RX header setting for BLE mode.

9.2.79 BLE Header Register 1 (Address: 0x84Eh)

Name	R/W	Bit 7	Bit 6	Bit 5	Bit 4	Bit 3	Bit 2	Bit 1	Bit 0
HEADER1	W	TXHDR7	TXHDR6	TXHDR5	TXHDR4	TXHDR3	TXHDR2	TXHDR1	TXHDR0
	R	RXHDR7	RXHDR6	RXHDR5	RXHDR4	RXHDR3	RXHDR2	RXHDR1	RXHDR0
Reset		0	0	0	0	0	0	0	0

9.2.80 ID Register 0 (Address: 0x84Fh)

Name	R/W	Bit 7	Bit 6	Bit 5	Bit 4	Bit 3	Bit 2	Bit 1	Bit 0
ID0	W/R	ID31	ID30	ID29	ID28	ID27	ID26	ID25	ID24
Reset		0	0	0	0	0	0	0	0

ID[31:0]: ID Data.

Once this address is accessed, ID Data is input/output in sequence corresponding to Write or Read.

9.2.81 ID Register 1 (Address: 0x850h)

Name	R/W	Bit 7	Bit 6	Bit 5	Bit 4	Bit 3	Bit 2	Bit 1	Bit 0
ID1	W/R	ID23	ID22	ID21	ID20	ID19	ID18	ID17	ID16
Reset		0	0	0	0	0	0	0	0

ID[31:0]: ID Data.

Once this address is accessed, ID Data is input/output in sequence corresponding to Write or Read.

9.2.82 ID Register 2 (Address: 0x851h)

Name	R/W	Bit 7	Bit 6	Bit 5	Bit 4	Bit 3	Bit 2	Bit 1	Bit 0
ID2	W/R	ID15	ID14	ID13	ID12	ID11	ID10	ID9	ID8
Reset		0	0	0	0	0	0	0	0

ID[31:0]: ID Data.

Once this address is accessed, ID Data is input/output in sequence corresponding to Write or Read.

9.2.83 ID Register 3 (Address: 0x852h)

Name	R/W	Bit 7	Bit 6	Bit 5	Bit 4	Bit 3	Bit 2	Bit 1	Bit 0
ID3	W/R	ID7	ID6	ID5	ID4	ID3	ID2	ID1	ID0
Reset		0	0	0	0	0	0	0	0

ID[31:0]: ID Data.

Once this address is accessed, ID Data is input/output in sequence corresponding to Write or Read.

9.2.84 DID Register 0 (Address: 0x853h)

Name	R/W	Bit 7	Bit 6	Bit 5	Bit 4	Bit 3	Bit 2	Bit 1	Bit 0
DID0	R	DID31	DID30	DID29	DID28	DID27	DID26	DID25	DID24
Reset		1	0	1	0	1	0	1	0

DID[31:0]: Device ID.

9.2.85 DID Register 1 (Address: 0x854h)

Name	R/W	Bit 7	Bit 6	Bit 5	Bit 4	Bit 3	Bit 2	Bit 1	Bit 0
DID1	R	DID23	DID22	DID21	DID20	DID19	DID18	DID17	DID16
Reset		1	0	0	0	0	0	0	1

DID[31:0]: Device ID.

9.2.86 DID Register 2 (Address: 0x855h)

Name	R/W	Bit 7	Bit 6	Bit 5	Bit 4	Bit 3	Bit 2	Bit 1	Bit 0
DID2	R	DID15	DID14	DID13	DID12	DID11	DID10	DID9	DID8
Reset		0	0	0	0	0	1	0	1

DID[31:0]: Device ID.

9.2.87 DID Register 3 (Address: 0x856h)

Name	R/W	Bit 7	Bit 6	Bit 5	Bit 4	Bit 3	Bit 2	Bit 1	Bit 0
DID3	R	DID7	DID6	DID5	DID4	DID3	DID2	DID1	DID0
Reset		1	0	1	0	0	0	0	1

DID[31:0]: Device ID.

9.2.88 EXT Register 1 (Address: 0x857h)

Name	R/W	Bit 7	Bit 6	Bit 5	Bit 4	Bit 3	Bit 2	Bit 1	Bit 0
EXT1	W/R	--	XEC	BREV	BGS	LIMB	ADCCS	BOD	REGR
Reset		--	1	0	0	0	0	0	0

XEC: Reserved. Should set to [1]

BREV: data byte reversion for TX data in the air

[0]: normal. [1]: reverted.

BGS: Reserved should set to [0]

LIMB: Reserved. Should set to [0]

ADCCS: Reserved. Should set to [0]

BOD: regulator input low voltage detect selection.

[0]: disable. [1]: enable.

REGR: pin7 "VDD_R" driver voltage output enable for 12bit ADC

[0]: disable. [1]: enable. Output voltage is equal to pin8 "VDD_A"

9.2.89 EXT Register 2 (Address: 0x858h)

Name	R/W	Bit 7	Bit 6	Bit 5	Bit 4	Bit 3	Bit 2	Bit 1	Bit 0
EXT2	W	VTRB3	VTRB2	VTRB1	VTRB0	VMRB3	VMRB2	VMRB1	VMRB0
Reset		0	0	0	0	0	0	0	0

VTRB[3:0]: Reserved. Should set to [0000]

VMRB[3:0]: Reserved. Should set to [0000]

9.2.90 EXT Register 3 (Address: 0x859h)

Name	R/W	Bit 7	Bit 6	Bit 5	Bit 4	Bit 3	Bit 2	Bit 1	Bit 0
EXT3	W	--	IFAS	CGC	IWA	IWC	LBG	VCS	VCSW
Reset		0	0	0	0	0	0	0	0

IFAS: Reserved for internal usage only.

CGC: Clock generation setting. [Fcsck = 32Mhz]: GRC=7, CGC=0. [Fcsck = 64Mhz]: GRC=3, CGC=1.

IWA: RXFE new IFAMP path gain

IWC: Reserved for internal usage only. Shall be set to [0].

LBG: Reserved for internal usage only.

VCS: Reserved.

VCSW: Reserved.

9.2.91 ADC Control Register (Address: 0x85Ah)

Name	R/W	Bit 7	Bit 6	Bit 5	Bit 4	Bit 3	Bit 2	Bit 1	Bit 0
ADCCTL	W	BUFS	CKS	--	MODE	MVS2	MVS1	MVS0	ADCE
	R	--	--	--	MODE	MVS2	MVS1	MVS0	ADCE
Reset		0	1	0	0	0	0	0	0

BUFS: input buffer select for 12 bit ADC.

[0]: disable. [1]: enable.

CKS: ADC clock selected.

[0]: 1 MHz

[1]: 4 MHz

MODE: ADC measurement mode.

[0]: Single mode. [1]: Continuous mode.

MVS [1:0]: ADC average times (for VCO calibration and RSSI).

[00]: Average 8 times. [01]: Average 16 times. [10]: Average 32 times. [11]: Average 64 times.

ADCE: ADC measurement enable

9.2.92 ADC Value Register 1 (Address: 0x85Bh)

Name	R/W	Bit 7	Bit 6	Bit 5	Bit 4	Bit 3	Bit 2	Bit 1	Bit 0
ADCAVG1	W	ADCIE	--	--	--	ADIVL	ADCYC	ENADC	DTMP
	R	MVADC11	MVADC10	MVADC9	MVADC8	ADC11	ADC10	ADC9	ADC8
Reset		0	--	--	--	0	0	0	0

ADCIE : 12-bits interrupt enable.

[0]: disable. [1]: enable.

ADIVL: Reserved. Should set to [0]

ADCYC: Reserved. Should set to [0]

ENADC: Enable ADC.

MVADC [11:0]: Moving average ADC output value

ADC [11:0]: ADC output value

MVADC [11:0]: Moving average ADC output value

9.2.93 ADC Value Register 2 (Address: 0x85Ch)

Name	R/W	Bit 7	Bit 6	Bit 5	Bit 4	Bit 3	Bit 2	Bit 1	Bit 0
ADCAVG2	R	MVADC7	MVADC6	MVADC5	MVADC4	MVADC3	MVADC2	MVADC1	MVADC0
Reset		--	--	--	--	--	--	--	--

MVADC [11:0]: Moving average ADC output value

9.2.94 ADC Value Register 3 (Address: 0x85Dh)

Name	R/W	Bit 7	Bit 6	Bit 5	Bit 4	Bit 3	Bit 2	Bit 1	Bit 0
ADCAVG3	R	ADC7	ADC6	ADC5	ADC4	ADC3	ADC2	ADC1	ADC0
Reset		--	--	--	--	--	--	--	--

ADC [11:0]: ADC output value

9.2.95 Timer Interval Register 1 (Address: 0x85Eh)

Name	R/W	Bit 7	Bit 6	Bit 5	Bit 4	Bit 3	Bit 2	Bit 1	Bit 0
TMRITV1	W/R	TMR_ITV[15:8]							
Reset		0	0	0	0	0	0	0	0

TMR_ITV[15:0]: Timer interval setting.

Timer interval can be set to be:

TMRCKS[1:0] = 00: 0.15625 ms ~ 10.24 s

TMRCKS[1:0] = 01: 0.3125 ms ~ 20.48 s

TMRCKS[1:0] = 10: 0.625 ms ~ 40.96 s

TMRCKS[1:0] = 11: 1.25 ms ~ 81.92 s

9.2.96 Timer Interval Register 2 (Address: 0x85Fh)

Name	R/W	Bit 7	Bit 6	Bit 5	Bit 4	Bit 3	Bit 2	Bit 1	Bit 0
TMRITV2	W/R	TMR_ITV[7:0]							
Reset		0	0	0	0	0	0	0	0

TMR_ITV[15:0]: Timer interval setting.

Timer interval can be set to be:

TMRCKS[1:0] = 00: 0.15625 ms ~ 10.24 s

TMRCKS[1:0] = 01: 0.3125 ms ~ 20.48 s

TMRCKS[1:0] = 10: 0.625 ms ~ 40.96 s

TMRCKS[1:0] = 11: 1.25 ms ~ 81.92 s

9.2.97 Timer Wake On Radio Register 0 (Address: 0x860h)

Name	R/W	Bit 7	Bit 6	Bit 5	Bit 4	Bit 3	Bit 2	Bit 1	Bit 0
TMRWOR0	W/R	--							
Reset		0	0	0	0	0	0	0	0

9.2.98 Timer Wake On Radio Register 1 (Address: 0x861h)

Name	R/W	Bit 7	Bit 6	Bit 5	Bit 4	Bit 3	Bit 2	Bit 1	Bit 0
TMRWOR1	W/R	TMRWORS	--	--	TMR_OFS4	TMR_OFS3	TMR_OFS2	TMR_OFS1	TMR_OFS0
Reset		0	0	0	0	0	0	0	0

TMRWORS: Timer WOR / WOT selection.

[0]: WOR

[1]: WOT

TMR_OFS[4:0]: Interrupt offset for 16-bits Timer.

9.2.99 Timer Control Register (Address: 0x862h)

Name	R/W	Bit 7	Bit 6	Bit 5	Bit 4	Bit 3	Bit 2	Bit 1	Bit 0
TMRCTL	W	TMRON	TMRIE	TMRIF	TMRCOR	TMRWOR	TMRCKS[1:0]		TMR_CE
	R	--	TMRIE	TMRIF	--	--	TMRCKS[1:0]		TMR_CE
Reset		0	0	0	0	0	0	0	0

TMRON: Turn on TMR.

TMRIE: Timer Interrupt Enable.

[0]: Disable.

[1]: Enable.

TMRIF: Timer Interrupt Flag. (Write "1" to clear)

TMRCOR : Timer CLK re-correct when sync.

[0]: disable.

[1]: enable

TMRWOR: Timer WOR function enable.

[0]: Disable.

[1]: Enable.

TMRCKS[1:0]: Select Timer Source Clock

[00]: 6.4 kHz

[01]: 3.2 kHz

[10]: 1.6 kHz

[11]: 0.8 kHz

TMR_CE: Start Timer counting.

[0]: Stop.

[1]: Start.

9.2.100 Power Control Register 0 (Address: 0x863h)

Name	R/W	Bit 7	Bit 6	Bit 5	Bit 4	Bit 3	Bit 2	Bit 1	Bit 0
PWRCTL0	W	CBG2	CBG1	CBG0	PDNS	STS	ENDL2	ENDL1	ENDL0
Reset		0	0	0	1	0	0	0	0

CBG[2:0]: Reserved for internal usage.

PDNS: Power manager to turn on REGOD Recommend PDNS = [0]

STS: Reserved for internal usage only. Shall be set to [0].

ENDL[2:0]: Reserved for internal usage only

9.2.101 Power Control Register 1 (Address: 0x864h)

Name	R/W	Bit 7	Bit 6	Bit 5	Bit 4	Bit 3	Bit 2	Bit 1	Bit 0
PWRCTL1	W	EBOD	ENAV	QDSA	ENDV	QDSD	CEL	SVREF	CELA
Reset		1	0	1	1	0	0	0	0

EBOD: Reserved for internal usage.

ENAV: REGOA and REGOS connection.

QDSA: quick discharge select for REGOA.

ENDV: REGOA is connected to REGOD.

QDSD: quick discharge select for REGOD.

CEL: Digital voltage select in standby mode. Recommend CEL = [0].

SVREF: Reserved for internal usage. Recommend SVREF = [0].

CELA: Reserved for internal usage.

PM mode: Low power operation select.

	MCU STOP
PM1(idle)	ENAV=1, QDSA=0, ENDV=1, QDSD=0
PM2(sleep)	ENAV=0, QDSA=1, ENDV=1, QDSD=0
PM3(deep sleep)	ENAV=0, QDSA=1, ENDV=0, QDSD=1

9.2.102 Power Control Register 2 (Address: 0x865h)

Name	R/W	Bit 7	Bit 6	Bit 5	Bit 4	Bit 3	Bit 2	Bit 1	Bit 0
PWRCTL2	W	RTCPUNIE	--	--	RCR1	RCR0	RGC1	RGC0	RCHC
Reset		0	--	--	0	0	0	1	0

RTCPUNIE: Reserved for internal usage. Shall be set to [0].

RCR[1:0]: Reserved for internal usage.

RGC[1:0]: Low power band-gap current select. Recommend RGC = [01]

RCHC: Reserved for internal usage.

9.2.103 Power Control Register 3 (Address: 0x866h)

Name	R/W	Bit 7	Bit 6	Bit 5	Bit 4	Bit 3	Bit 2	Bit 1	Bit 0
PWRCTL3	W	MR7	MR6	MR5	MR4	MR3	MR2	MR1	MR0
Reset		0	0	0	0	0	0	0	0

MR[7:0]: Reserved for internal usage.

9.2.104 Power Control Register 4 (Address: 0x867h)

Name	R/W	Bit 7	Bit 6	Bit 5	Bit 4	Bit 3	Bit 2	Bit 1	Bit 0
PWRCTL4	W	MS7	MS6	MS5	MS4	MS3	MS2	MS1	MS0
Reset		0	0	0	0	0	0	0	0

MS[7:0]: Reserved for internal usage.

9.2.105 DC_SHIFT(Address: 0x868h)

Name	R/W	Bit 7	Bit 6	Bit 5	Bit 4	Bit 3	Bit 2	Bit 1	Bit 0

DCSFT	W/R	dc_shift[7:0]							
Reset		0	1	0	1	0	1	0	0

dc_shift [7:0]: DC average by ID initial dc value shift setting. (NOTE): DC_SHIFT[7] is signed bit.

9.2.106 TX_5DLY(Address: 0x869h)

Name	R/W	Bit 7	Bit 6	Bit 5	Bit 4	Bit 3	Bit 2	Bit 1	Bit 0
TX5DY	W	HDRSW	EARTS	EACKS	TX_5DLY[4:0]				
Reset		0	0	0	0	0	0	0	0

HDRSW: switch header length

[1]: 6 bits

[0]: 5 bits

EARTS: Auto resend (EARTS=1 → TX)

EACKS: Auto ack (EACKS=1 → RX)

TX_5DLY [4:0]: TX data output delay timing after PDN_TX enable.

9.2.107 ACKRT (Address: 0x87Ch)

Name	R/W	Bit 7	Bit 6	Bit 5	Bit 4	Bit 3	Bit 2	Bit 1	Bit 0
ACKRT	W	--	--	LL_TIME_OUT[5:0]					
Reset		0	0	0	1	0	0	0	1

LL_TIME_OUT[5:0]: RX timeout register, Timeout = 20us x (1+LL_TIME_OUT)

AMICCOM CONFIDENTIAL

10.SOC Architectural Overview

A8105 microcontroller is instruction set compatible with the industry standard 8051. Besides FSK/GFSK RF transceiver, A8105 integrates many features, three 8/16bit counters/timers, watchdog timer, RTC, UART, SPI interface, I²C interface, 2 channels PWM, 8 channels ADC and battery detector, The interrupt controller is extended to support 6 interrupt sources; watchdog timer, RTC, SPI, I²C, ADC and RF. A8105 includes TTAG (2-wire) debug circuitry that provides full time, real-time, in-circuit debugging.

10.1 Pipeline 8051 CPU

A8105 microcontroller has pipelined RSIC architecture 10 times faster compared to standard 8051 architecture. The pipeline 8051 is fully compatible with the MCS-51TM instruction set. User can use standard 8051 assemblers and compilers to develop software. The pipelined architecture 8051 has greatly increases its instruction throughput over the standard 8051 architecture. A8105 has a total of 110 instructions. The table below shows the total number of instructions that require each execution time. For more detail information of instruction, please refer Table 10.1.

Clock to Execute	1	2	3	4	5	6
Number of instructions	24	38	29	11	8	1

10.2 Memory Organization

The memory organization of A8105 is similar to the standard 8051. The memory organization is shown as figure 10.1

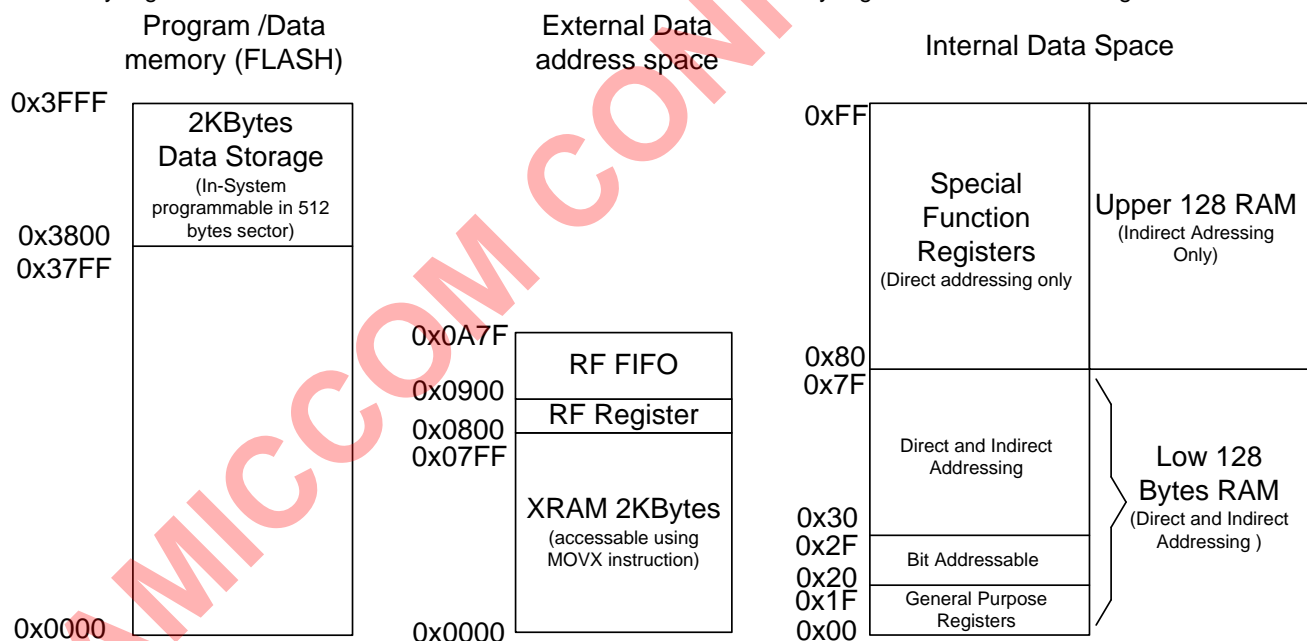

Figure 10.1 Memory Organization

10.2.1 Program memory

The standard 8051 core has 64KB program memory space. A8105 implement 16KB flash. The last 2KB program memory space (0x 3800 ~ 0x3FFF) supports IAP (In-Application Programming) function. The each block size in this area is 128Bytes. User has 16 blocks in 2KB program memory space to storage data. Program memory is normally assumed to be read-only. However, A8105 can write to program memory by IAP function call. Please reference Application note to write program memory for more detail.

10.2.2 Data memory

The A8105 includes 256 bytes of internal RAM mapped into the data memory space from 0x00 through 0xFF. The lower 128 bytes of data memory are used for general purpose registers and scratch pad memory. Either direct or indirect addressing may be used to access the lower 128 bytes of data memory. Locations 0x00 through 0x1F are addressable as four banks of general

purpose registers, each bank consisting of eight byte-wide registers. The next 16 bytes, locations 0x20 through 0x2F, may either be addressed as bytes or as 128 bit locations accessible with the direct addressing mode. The upper 128 bytes of data memory are accessible only by indirect addressing. This region occupies the same address space as the Special Function Registers (SFR) but is physically separate from the SFR space. The addressing mode used by an instruction when accessing locations above 0x7F determines whether the CPU accesses the upper 128 bytes of data memory space or the SFRs. Instructions that use direct addressing will access the SFR space. Instructions using indirect addressing above 0x7F access the upper 128 bytes of data memory. Figure 10.1 illustrates the data memory organization of the A8105.

10.2.3 General Purpose Registers

The lower 32 bytes of data memory, locations 0x00 through 0x1F, may be addressed as four banks of general-purpose registers. Each bank consists of eight byte-wide registers designated R0 through R7. Only one of these banks may be enabled at a time. Two bits in the program status word, RS0 (PSW.3) and RS1 (PSW.4), select the active register bank (see description of the PSW in SFR Definition 9.1). This allows fast context switching when entering subroutines and interrupt service routines. Indirect addressing modes use registers R0 and R1 as index registers.

10.2.4 Bit Addressable Locations

In addition to direct access to data memory organized as bytes, the sixteen data memory locations at 0x20 through 0x2F are also accessible as 128 individually addressable bits. Each bit has a bit address from 0x00 to 0x7F. Bit 0 of the byte at 0x20 has bit address 0x00 while bit7 of the byte at 0x20 has bit address 0x07. Bit 7 of the byte at 0x2F has bit address 0x7F. A bit access is distinguished from a full byte access by the type of instruction used (bit source or destination operands as opposed to a byte source or destination). The MCS-51™ assembly language allows an alternate notation for bit addressing of the form XX.B where XX is the byte address and B is the bit position within the byte. For example, the instruction: MOV C, 22.3h ;moves the Boolean value at 0x13 (bit 3 of the byte at location 0x22) into the Carry flag.

10.2.5 Special Function Registers

The direct-access data memory locations from 0x80 to 0xFF constitute the special function registers (SFRs). The SFRs provide control and data exchange with the CIP-51's resources and peripherals. The CIP-51 duplicates the SFRs found in a typical 8051 implementation as well as implementing additional SFRs used to configure and access the sub-systems unique to the MCU. This allows the addition of new functionality while retaining compatibility with the MCS-51™ instruction set. Table 9.2 lists the SFRs implemented in the CIP-51 System Controller.

The SFR registers are accessed anytime the direct addressing mode is used to access memory locations from 0x80 to 0xFF. SFRs with addresses ending in 0x0 or 0x8 (e.g. P0, TCON, SCON0, IE, etc.) are bit-addressable as well as byte-addressable. All other SFRs are byte-addressable only. Unoccupied addresses in the SFR space are reserved for future use. Accessing these areas will have an indeterminate effect and should be avoided.

10.2.6 Stack

A8105 has 8-bit stack point called SP (0x81) located in the internal RAM space. It is incremented before data is stored during PUSH and CALL execution and decremented after data is popped during POP, RET and RETI execution. In the other words it always points to the last valid stack byte. The SP is accessed as any other SFRs.

Address/Name	R/W	Bit 7	Bit 6	Bit 5	Bit 4	Bit 3	Bit 2	Bit 1	Bit 0
81h SP	R/W								
Reset		0	0	0	0	0	1	1	1

Stack pointer register

10.2.7 Data Pointer Register

A8105 are implemented dual data pointer registers, auto increment and auto decrement to speed up data block copying. DPTR0 and DPTR1 are located at four SFR addresses. Active DPTR register is selected by SEL bit (0x86.0). If SEL = 0 the DPTR0 is selected otherwise DPTR1.

Address/Name	R/W	Bit 7	Bit 6	Bit 5	Bit 4	Bit 3	Bit 2	Bit 1	Bit 0
82h DPL0	R/W								
Reset		0	0	0	0	0	0	0	0

Address/Name	R/W	Bit 7	Bit 6	Bit 5	Bit 4	Bit 3	Bit 2	Bit 1	Bit 0
83h DPH0	R/W								

Reset		0	0	0	0	0	0	0	0
-------	--	---	---	---	---	---	---	---	---

Data Pointer Register DPTR0

Address/Name	R/W	Bit 7	Bit 6	Bit 5	Bit 4	Bit 3	Bit 2	Bit 1	Bit 0
84h DPL1	R/W								
Reset		0	0	0	0	0	0	0	0

Address/Name	R/W	Bit 7	Bit 6	Bit 5	Bit 4	Bit 3	Bit 2	Bit 1	Bit 0
85h DPH1	R/W								
Reset		0	0	0	0	0	0	0	0

Data Pointer 1 Register DPTR1

Address/Name	R/W	Bit 7	Bit 6	Bit 5	Bit 4	Bit 3	Bit 2	Bit 1	Bit 0
86h DPS	R/W	ID1	ID0	TSL	AU1	AU0	-	-	SEL
Reset		0	0	0	0	0	0	0	0

Data Pointers Select Register

ID[1:0] - Increment/decrement function select. See table below.

TSL - Toggle select enable. When set, this bit allows the following DPTR related instruction to toggle the SEL bit following execution of the instruction:

```

MOVC A, @A+DPTR
INC DPTR
MOVX @DPTR, A
MOVX A, @DPTR
MOV DPTR, #data16
  
```

When TSL=0, DPTR related instructions do not affect state of SEL bit.

AU -When set to '1' performs automatic increment(0)/ decrement(1) of selected DPTR according to IDx bits, after each MOVX @DPTR, MOVC @DPTR instructions

SEL - Select active data pointer – see table below

- - Unimplemented bit. Read as 0 or 1.

ID1	ID0	SEL=1	SEL=0
0	0	INC DPTR1	INC DPTR
0	1	INC DPTR1	DEC DPTR
1	0	DEC DPTR1	INC DPTR
1	1	DEC DPTR1	DEC DPTR

Table DPTR0, DPTR1 operations

Selected data pointer register is used in the following instructions:

```

MOVX @DPTR,A
MOVX A,@DPTR
MOVC A,A+DPTR
JMP @A+DPTR
INC DPTR
MOV DPTR,#data16
  
```

10.2.8 RF Registers and RF FIFO

RF registers are RF radio control registers and located in 0x0800 ~ 0x08ff. Please refer the section 9.2 and the related function setting in the datasheet. A8105 has 384 Bytes FIFO located from 0x0900 to 0x0A7F. There are 128 bytes FIFO from 0x0900 ~ 0x097F for data transmitting. There are 128 bytes FIFO from 0x0980 ~ 0x09FF for data receiving.

10.3 Instruction set

A8105 use a high performance, pipeline 8051 core and it is fully compatible with the standard MCS-51™ instruction set. Standard 8051 development tools can be used to develop software for A8105. All A8105 instruction sets are the binary and functional equivalent of the MCS-51™. However, instruction timing is different with the standard 8051. All instruction timings are specified in the terms of clock cycles as shown in the table 10.1

Mnemonic	Description	Code	Bytes	Cycles
ACALL addr11	Absolute subroutine call	0x11-0xF1	2	4
ADD A,#data	Add immediate data to accumulator	0x24	2	2
ADD A,@Ri	Add indirect RAM to accumulator	0x26-0x27	1	2
ADD A,direct	Add direct byte to accumulator	0x25	2	2
ADD A,Rn	Add register to accumulator	0x28-0x2F	1	1
ADDC A,#data	Add immediate data to A with carry flag	0x34	2	2
ADDC A,@Ri	Add indirect RAM to A with carry flag	0x36-0x37	1	2
ADDC A,direct	Add direct byte to A with carry flag	0x35	2	2
ADDC A,Rn	Add register to accumulator with carry flag	0x38-0x3F	1	1
AJMP addr11	Absolute jump	0x01-0xE1	2	3
ANL C,/bit	AND complement of direct bit to carry	0xB0	2	2
ANL A,#data	AND immediate data to accumulator	0x54	2	2
ANL A,@Ri	AND indirect RAM to accumulator	0x56-0x57	1	2
ANL A,direct	AND direct byte to accumulator	0x55	2	2
ANL A,Rn	AND register to accumulator	0x58-0x5F	1	1
ANL C,/bit	AND direct bit to carry flag	0x82	2	2
ANL direct,#data	AND immediate data to direct byte	0x53	3	3
ANL direct,A	AND accumulator to direct byte	0x52	2	3
CJNE @Ri,#data	Compare immediate to ind. and jump if not equal	0xB6-0xB7	3	5
CJNE A,#data	Compare immediate to A and jump if not equal	0xB4	3	4
CJNE A,direct	Compare direct byte to A and jump if not equal	0xB5	3	5
CJNE Rn,#data	Compare immediate to reg. and jump if not equal	0xB8-0xBF	3	4
CLR A	Clear accumulator	0xE4	1	1
CLR bit	Clear direct bit	0xC2	2	3
CLR C	Clear carry flag	0xC3	1	1
CPL A	Complement accumulator	0xF4	1	1
CPL bit	Complement direct bit	0xB2	2	3
CPL C	Complement carry flag	0xB3	1	1
DA A	Decimal adjust accumulator	0xD4	1	3
DEC @Ri	Decrement indirect RAM	0x16-0x17	2	3
DEC A	Decrement accumulator	0x14	1	1
DEC direct	Decrement direct byte	0x15	1	3
DEC Rn	Decrement register	0x18-0x1F	1	2

DIV A,B	Divide A by B	0x84	1	6
DJNZ direct,rel	Decrement direct byte and jump if not zero	0xD5	3	5
DJNZ Rn,rel	Decrement register and jump if not zero	0xD8-0xDF	2	4
INC @Ri	Increment indirect RAM	0x06-0x07	1	3
INC A	Increment accumulator	0x04	1	1
INC direct	Increment directbyte	0x05	2	3
INC Rn	Increment register	0x08-0x0F	1	2
INC DPTR	Increment data pointer	0xA3	1	1
JB bit,rel	Jump if direct bit is set	0x20	3	5
JBC bit,directre	Jump if direct bit is set and clear bit	0x10	3	5
JC rel	Jump if carry flag is set	0x40	2	3
JMP@A+DPTR	Jump indirect relative to the DPTR	0x73	1	5
JNB bit,rel	Jump if direct bit is not set	0x30	3	5
JNC	Jump if carry flag is not set	0x50	2	3
JNZ rel	Jump if accumulator is not zero	0x70	2	4
JZ rel	Jump if accumulator is zero	0x60	2	4
LCALL addr16	Long subroutine call	0x12	3	4
LJMP addr16	Long jump	0x02	3	4
MOV A,@Ri	Move indirect RAM to accumulator	0xE6-0xE7	1	2
MOV bit,C	Move carry flag to direct bit	0x92	2	3
MOV @Ri,#data	Move immediate data to indirect RAM	0x76-0x77	2	2
MOV @Ri,A	Move accumulator to indirect RAM	0xF6-0xF7	1	2
MOV @Ri,direct	Move direct byte to indirect RAM	0xA6-0xA7	2	3
MOV A,#data	Move immediate data to accumulator	0x74	2	2
MOV A,direct	Move direct byte to accumulator	0xE5	2	2
MOV A,Rn	Move register to accumulator	0xE8-0xEF	1	1
MOV C,bit	Move direct bit to carry flag	0xA2	2	2
MOV direct,#data	Move immediate data to direct byte	0x75	3	3
MOV direct,@Ri	Move indirect RAM to direct byte	0x86-0x87	2	3
MOV direct,A	Move accumulator to direct byte	0xF5	2	2
MOV direct,Rn	Move register to direct byte	0x88-0x8F	2	2
MOV direct1,direct2	Move direct byte to direct byte	0x85	3	3
MOV DPTR,#data16	Load 16-bit constant in to active DPTR	0x90	3	3
MOV Rn,#data	Move immediate data to register	0x78-0x7F	2	2
MOV Rn,A	Move accumulator to register	0xF8-0xFF	1	1
MOV Rn,direct	Move direct byte to register	0xA8-0xAF	2	3
MOVC A,@A+DPTR	Move code byte relative to DPTR to accumulator	0x93	1	5
MOVC A,@A+PC	Move code byte relative to PC to accumulator	0x83	1	4

MOVX @DPTR,A	Move A to external SRAM (16-bitaddress)	0xF0	1	1
MOVX @Ri,A	Move A to external RAM (8-bitaddress)	0xF2-0xF3	1	2
MOVX A,@DPTR	Move external RAM (16-bitaddress) to A	0xE0	1	1
MOVX A,@Ri	Move external RAM (8-bitaddress) to A	0xE2-0xE3	1	2
MUL A,B	Multiply A and B	0xA4	1	2
NOP	No operation	0x00	1	1
ORL direct,A	OR accumulator to direct byte	0x42	2	3
ORL A,#data	OR immediate data to accumulator	0x44	2	2
ORL A,@Ri	OR indirect RAM to accumulator	0x46-0x47	1	2
ORL A,direct	OR direct byte to accumulator	0x45	2	2
ORL A,Rn	OR register to accumulator	0x48-0x4F	1	1
ORL C,/bit	OR complement of direct bit to carry	0xA0	2	2
ORL C,bit	OR direct bit to carry flag	0x72	2	2
ORL direct,#data	OR immediate data to direct byte	0x43	3	3
POP direct	Pop direct byte from internal ram stack	0xD0	2	2
PUSH direct	Push direct byte on to internal ram stack	0xC0	2	3
RET	Return from subroutine	0x22	1	4
RETI	Return from interrupt	0x32	1	4
RL A	Rotate accumulator left	0x23	1	1
RLC A	Rotate accumulator left through carry	0x33	1	1
RR A	Rotate accumulator right	0x03	1	1
RRC A	Rotate accumulator right through carry	0x13	1	1
SETB C	Set carry flag	0xD3	1	1
SETB bit	Set direct bit	0xD2	2	3
SJMP rel	Short jump (relative address)	0x80	2	3
SUBB A,@Ri	Subtract indirect RAM from A with borrow	0x96-0x97	1	2
SUBB A,direct	Subtract direct byte from A with borrow	0x95	2	2
SUBB A,#data	Subtract immediate data from A with borrow	0x94	2	2
SUBB A,Rn	Subtract register from A with borrow	0x98-0x9F	1	1
SWAP A	Swap nibbles within the accumulator	0xC4	1	1
XCH A,@Ri	Exchange indirect RAM with accumulator	0xC6-0xC7	1	3
XCH A,direct	Exchange direct byte with accumulator	0xC5	2	3
XCH A,Rn	Exchange register with accumulator	0xC8-0xCF	1	2
XCHD A,@Ri	Exchange low-order nibble indirect RAM with A	0xD6-0xD7	1	3
XRL direct,#data	ExclusiveOR immediate data to direct byte	0x63	3	3
XRL A,#data	ExclusiveOR immediate data to accumulator	0x64	2	2
XRL A,@Ri	ExclusiveOR indirect RAM to accumulator	0x66-0x67	1	2
XRL A,direct	ExclusiveOR direct byte to accumulator	0x65	2	2

XRL A,Rn	ExclusiveOR register to accumulator	0x68-0x6F	1	1
XRL direct,A	ExclusiveOR accumulator to direct byte	0x62	2	3

Table 10.1 Instruction set sorted by alphabet

10.4 Interrupt handler

This section describes 8051 external interrupts and their functionality. For peripheral related interrupts, please refer to an appropriate peripheral section. The external interrupts symbol is shown in figure above. And the pins functionality is described in the following table. All pins are one directional. There are no three-state output pins and internal signals.

Name	ACTIVE	TYPE	DESCRIPTION
int0(P3.2)	low/falling	Input	External interrupt 0 line
int1(P3.3)	low/falling	Input	External interrupt 1 line
int2(P0.7)	low	Input	External interrupt 2 line
int3*(P1.2)	low	Input	External interrupt 3 line
int4*(P1.3)	low	Input	External interrupt 4 line
RFINT	failing		
KEYINT	failing		

Table 10.2 External interrupts pins description

Note1 : Number of external interrupt sources depends on core configuration. It can be adjusted upon request. The int0 & int1 sources are always available. Please check your configuration.

Note2 : *pin functionality depends on compare / capture unit.

10.4.1 FUNCTIONALITY

All 8051 IP cores have implemented two levels interrupt priority control. Each external interrupt can be in high or low level priority group by setting or clearing a bit in the IP(0xB8), EIP(0xF8), and DEVICR(0xCF) registers. External interrupt pins are activated at low level or by a falling edge. Interrupt requests are sampled each system clock at the rising edge of CLK.

Interrupt flag	Function	Active level/edge	Flag resets	Vector ¹	Natural priority
IE0	Device pin INT0	Low/falling	Hardware	0x03	1
TF0	Internal, Timer 0	-	Hardware	0x0B	2
IE1	Device pin INT1	Low/falling	Hardware	0x13	3
TF1	Internal, Timer 1	-	Hardware	0x1B	4
TI & RI	Interrupt, UART	-	Software	0x23	5
TF2	Interrupt, Timer 2	-	Software	0x2B	6
Reserved	Reserved	-	Software	0x33	7
INT2F	Device pin INT2	Low	Hardware	0x3B	8
INT3F	Device pin INT3	Low	Hardware	0x43	9
INT4F	Device pin INT4	Low	Hardware	0x4B	10
RFINT	Interrupt, RFINT	-Falling	Software	0x53	11
KEYINT	Interrupt, KeyINT	-Falling	Software	0x5B	12
WDIF	Internal, Watchdog	-	Software	0x63	13
I2CMIF	Internal, I2C MASTER MODULE	-	Software	0x6B	14
I2CSIF SPIIF	Internal, DI2CS/ Internal, SPI	-	Software	0x73	15
Reserved	Reserved	-	Hardware	0x7B	16
Reserved	Reserved	-	Hardware	0x83	17

Table10.3 8051 interrupts summary

1- This is a default location when IRQ_INTERVAL = 8, in other case is equal to (IRQ_INTERVAL* n) + 3, when n = (natural Priority - 1)

Each interrupt vector can be individually enabled or disabled by setting or clearing a corresponding bit in the IE(0xA8), EIE(0xE8), DEVICR(0xCF). The IE contains global interrupt system disable(0) / enable(1) bit called EA.

IE register (0xA8)

Address/Name	R/W	Bit 7	Bit 6	Bit 5	Bit 4	Bit 3	Bit 2	Bit 1	Bit 0
A8h IE	R/W	EA	-	ET2	ES0	ET1	EX1	ET0	EX0

Reset		0	0	0	0	0	0	0	0
-------	--	---	---	---	---	---	---	---	---

- EA** : Enable global interrupts
- EX0** : Enable INT0 interrupts
- ET0** : Enable Timer 0 interrupts
- EX1** : Enable INT1 interrupts
- ET1** : Enable Timer 1 interrupts
- ES** : Enable UART interrupts
- ET2** : Enable Timer 2 interrupts

All of bits that generate interrupts can be set or cleared by software, with the same result as if they had been set or cleared by hardware. That is, interrupts can be generated or pending interrupts can be cancelled by software. The exceptions of this rule are the request flags IE0 and IE1. If the external interrupts 0 or 1 are programmed to be level activated, IE0 and IE1 are controlled by the external source via pin INT0 and INT1, respectively. Thus, writing a one to these bits will not set the request flag IE0 and/or IE1. The same exception is related to INT2F, INT3F, INT4F, RFINTF, and KEYINTF – external interrupts number 2, 3, 4, 5, 6.

IP register (0xB8)

Address/Name	R/W	Bit 7	Bit 6	Bit 5	Bit 4	Bit 3	Bit 2	Bit 1	Bit 0
B8h IP	R/W	-	-	PT2	PS	PT1	PX1	PT0	PX0
Reset		0	0	0	0	0	0	0	0

- PX0** : INT0 priority level control (at 1-high-level)
- PT0** : Timer 0 priority level control (at 1-high-level)
- PX1** : INT1 priority level control (at 1-high-level)
- PT1** : Timer 1 priority level control (at 1-high-level)
- PS** : UART priority level control (at 1-high-level)
- PT2** : Timer 2 priority level control (at 1-high-level)

TCON register (0x88)

Address/Name	R/W	Bit 7	Bit 6	Bit 5	Bit 4	Bit 3	Bit 2	Bit 1	Bit 0
88h TCON	R/W	TF1	TR1	TF0	TR0	IE1	IT1	IE0	IT0
Reset		0	0	0	0	0	0	0	0

- IT0** : INT0 level (at 0) / edge (at 1) sensitivity
- IT1** : INT1 level (at 0) / edge (at 1) sensitivity
- IE0** : INT0 interrupt flag
Cleared by hardware when processor branches to interrupt routine
- IE1** : INT1 interrupt flag
Cleared by hardware when processor branches to interrupt routine
- TF0** : Timer 0 interrupt (overflow) flag
Cleared by hardware when processor branches to interrupt routine
- TF1** : Timer 1 interrupt (overflow) flag
Cleared by hardware when processor branches to interrupt routine

SCON register (0x98)

Address/Name	R/W	Bit 7	Bit 6	Bit 5	Bit 4	Bit 3	Bit 2	Bit 1	Bit 0
98h SCON	R/W	SM0	SM1	SM2	REN	TB8	RB8	TI	RI
Reset		0	0	0	0	0	0	0	0

RI : UART receiver interrupt flag
 TI : UART transmitter interrupt flag

EIE register (0xE8)

Address/Name	R/W	Bit 7	Bit 6	Bit 5	Bit 4	Bit 3	Bit 2	Bit 1	Bit 0
E8h EIE	R/W	EI2CS ESPI	EI2CM	EWDI	EKEYINT	ERFINT	EINT4	EINT3	EINT2
Reset		0	0	0	0	0	0	0	0

EINT2 : Enable INT2 interrupts
EINT3 : Enable INT3
EINT4 : Enable INT4
ERFINT : Enable RF INT
EKEYINT : Enable KEYINT
EWDI : Enable Watchdog interrupts
EI2CM : Enable I2C MASTER MODULE interrupts
EI2CS : Enable I2C MODULE interrupts
ESPI : Enable SPI MODULE interrupts

EIP register (0xF8)

Address/Name	R/W	Bit 7	Bit 6	Bit 5	Bit 4	Bit 3	Bit 2	Bit 1	Bit 0
F8h EIP	R/W	PI2CS PSPI	PI2CM	PWDI	PKEYINT	PRFINT	PINT4	PINT3	PINT2
Reset		0	0	0	0	0	0	0	0

PINT2 : INT2 priority level control (at 1-high-level)
PINT3 : INT3/Compare 0 priority level control (at 1-high-level)
PINT4 : INT4/Compare 1 priority level control (at 1-high-level)
PRFINT : RFINT priority level control (at 1-high-level)
PKEYINT : KEYINT priority level control (at 1-high-level)
PWDI : Watchdog priority level control (at 1-high-level)
PI2CM : I2C MASTER MODULE priority level control (at 1-high-level)
PI2CS : I2C MODULE priority level control (at 1-high-level)
PSPI : SPI MODULE priority level control (at 1-high-level)

EIF register (0x91)

Address/Name	R/W	Bit 7	Bit 6	Bit 5	Bit 4	Bit 3	Bit 2	Bit 1	Bit 0
91h EIF	R/W	I2CSF SPIF	I2CMF	-	KEYINTF	RFINTF	INT4F	INT3F	INT2F
Reset		0	0	0	0	0	0	0	0

INT2F : INT2 interrupt flag
 Should be cleared by external hardware when processor branches to interrupt routine. This bit is a copy of INT2 pin updated every CLK period. It cannot be set by software.

INT3F* : INT3/Compare 0 interrupt flag
 Should be cleared by external hardware when processor branches to interrupt routine. It cannot be set by software.

INT4F* : INT4/Compare 1 interrupt flag
 Should be cleared by external hardware when processor branches to interrupt routine. It cannot be set by software.

RFINTF : RFINT interrupt flag
 Must be cleared by software writing 0x08 when controlled by RFINT.

KEYINTF : KEYINT interrupt flag
 Must be cleared by software writing 0x10 when controlled by KEYINT.

I2CMIF : I2C MASTER MODULE interrupt flag. It must be cleared by software writing 0x40. It cannot be set by software

I2CSIF : I2C MODULE interrupt flag

SPIIF : SPI MODULE interrupt flag
 Software should determine the source of interrupt by checking both modules' interrupt related bits. It must be cleared by software writing 0x80. It cannot be set by software.

10.5 Reset source

Reset circuitry allows A8105 to be easily placed in a predefined default condition. LVD, Reset, POR, and Watchdog signal will reset 8153 when they happen.

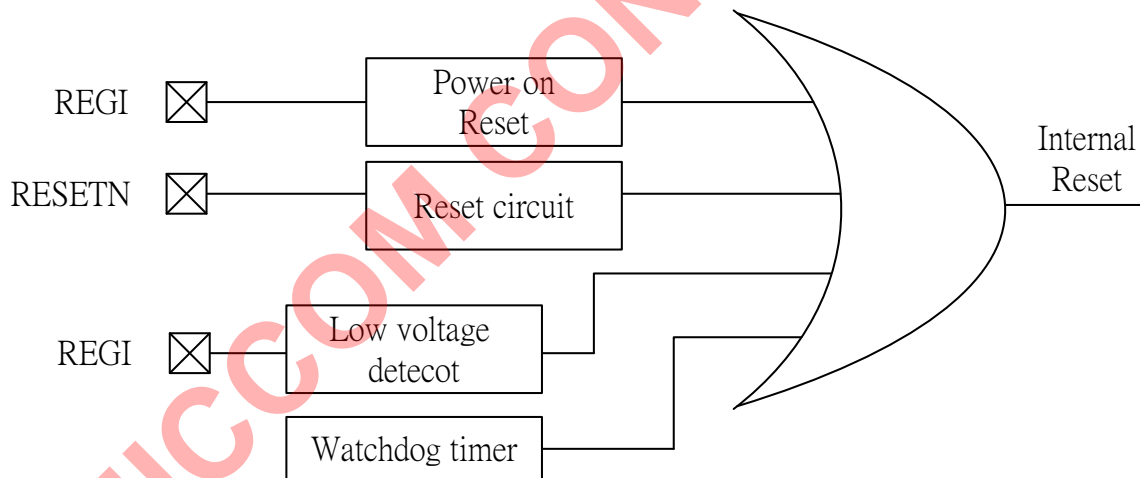

Figure 10.2 Reset source

RSFLAG: Reset Flag(0xBA):

Address/Name	R/W	Bit 7	Bit 6	Bit 5	Bit 4	Bit 3	Bit 2	Bit 1	Bit 0
BAh RSFLAG	R	-	-	-	-	-	LVDF	RESETNF	PORF
Reset		0	0	0	0	0	0	0	1

Write any data to RSFLAG to clear all bits.

PORF (power-on reset flag)

- = 1: Occurred Power-on Reset
- = 0: No Power-on Reset

RESETNF (resetrn flag)

- = 1: Occurred ResetN reset
- = 0: No ResetN resetno resetrn reset

LVD (Low voltage detect) flag

- = 1: Occurred Low Voltage Reset

= 0: No Low Voltage reset

Please refer the figure 10.3 and 10.4 for the timing diagram for stable power of reset signal and internal behavior of CPU.

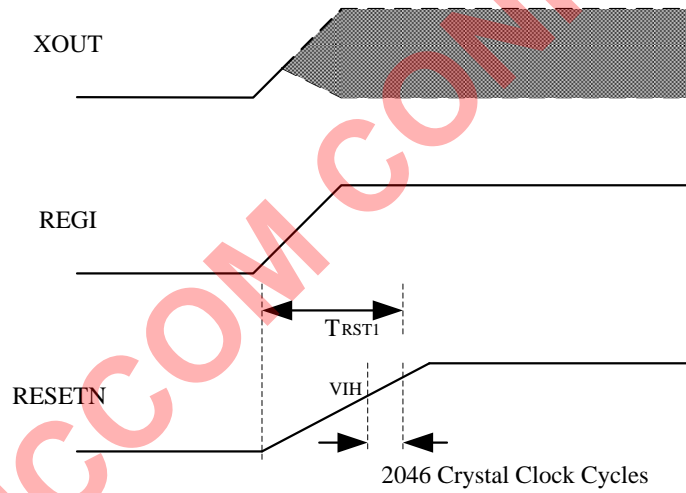

T_{RSTI} : According to RESETN's RC delay (standard module is about 50ms)

Figure 10.3 Timing Diagram for stable power to the release of RESETN

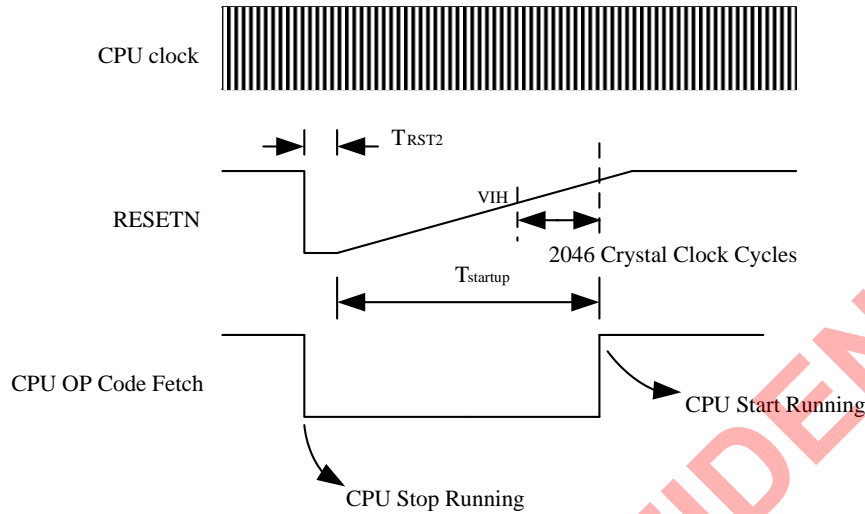

T_{RST2} : 2 Crystal Clock Cycles (min)

$T_{startup}$: 2046 Crystal Clock Cycles + RESETN's RC delay (standard module is about 50ms)

Figure 10.4 Timing Diagram for RESETN control sequence

10.6 Clock source

A8105 has three clock source, crystal oscillator (pin 13,14/ Xi, XO), RTC crystal (pin 1,2/ P3.6, P3.7/ RTC_I, RTC_O) and internal RC oscillator. In the MCU part (digital peripherals), user chooses the suitable clock source by power consumptions and performance. In the RF part, the clock source only comes from XO..

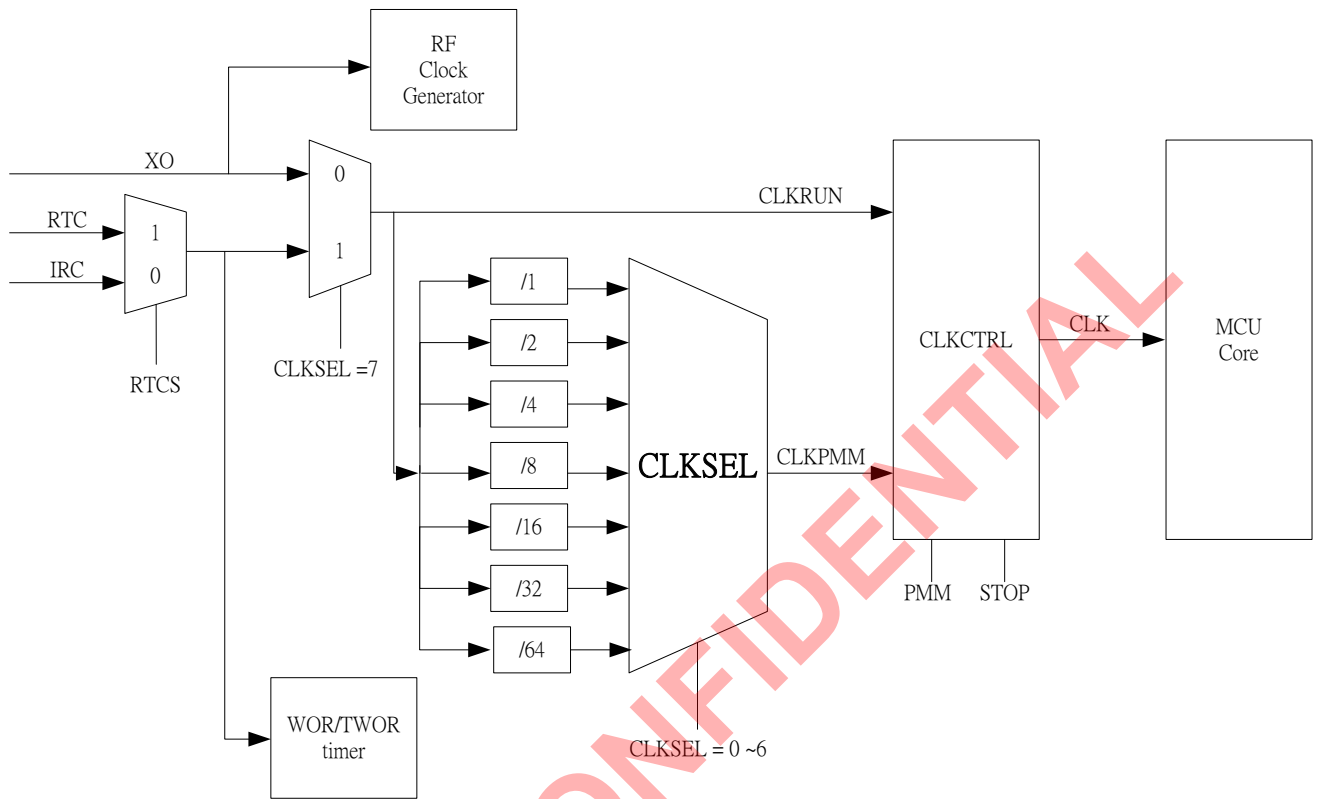

Figure 10.3 Whole chip clock

AMICCOM CONFIDENTIAL

11. I/O Ports

A8105 has two type of digitla I/O Pins. One is 24 pins and the other is 28 pins. In 24pins, there are separated to 3 Ports (Port0, Port1 and Port3) and each of the Port pin can be defined as general-purpose I/O (GPIO) or peripheral I/O signals connected to the timers, UART, I2C and SPI functions. In 28pins, there are extra 4pins of Port2 and they are Port2.0 ~ Port2.3. Thus, each pin can also be used to wake A8105 up from sleep mode. User can select each pin function by setting register. Each port has itself port register like P0 (0x80), P1 (0x90), P2(0xA0) and P3 (0xB0) that are both byte addressable and bit addressable. When reading, the logic levels of the Port's input pins are returned. Each port has three registers to setting Pull-up (PUN), Output-enable (OE) and Wake-up enable (WUN). As shown the bellow block diagram, Fig. 11.1. Unused I/O pins should have a defined level and not be left floating. One way to do this is to leave the pin unconnected and configure the pin as a general-purpose I/O input with pull-up resistor.

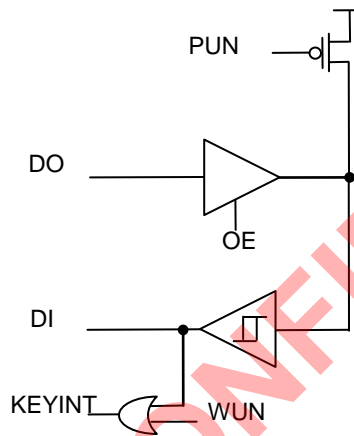

Figure11.1 Ports I/O block diagram

OE	PUN	P	DI
0	0	1	1
0	1	HZ	INH
1	X	DO	DO

Table 11.1 OE and PUN setting and Output(P) and Input(DI)

WUN	KEYINT
0	Enable
1	Disable

Table 11.2 WUN setting and KEYINT source

11.1 FUNCTIONALITY

It has three 8-bit full bi-directional ports, P0, P1 and P3. Each port bit can be individually accessed by bit addressable instructions.

Address/Name	R/W	Bit 7	Bit 6	Bit 5	Bit 4	Bit 3	Bit 2	Bit 1	Bit 0
80h P0	R/W								
Reset		0	0	0	0	0	0	0	0

Port 0 register

Address/Name	R/W	Bit 7	Bit 6	Bit 5	Bit 4	Bit 3	Bit 2	Bit 1	Bit 0
90h P1	R/W								

Reset		0	0	0	0	0	0	0	0
-------	--	---	---	---	---	---	---	---	---

Port 1 register

Address/Name	R/W	Bit 7	Bit 6	Bit 5	Bit 4	Bit 3	Bit 2	Bit 1	Bit 0
A0h P2	R/W								
Reset		0	0	0	0	0	0	0	0

Port 2 register

Address/Name	R/W	Bit 7	Bit 6	Bit 5	Bit 4	Bit 3	Bit 2	Bit 1	Bit 0
B0h P3	R/W								
Reset		0	0	0	0	0	0	0	0

Port 3 register

Read and write accesses to the I/O port are performed via their corresponding SFRs P0(0x80), P1(0x90), and P3(0xB0). Some port-reading instructions read the data register and others read the port's pin. The "Read-Modify-Write" instructions are directed to the data registers and are shown below. All the other instructions used to read a port exclusively read the port's pin.

Instruction	Function description
ANL	Logic AND
ORL	Logic OR
XRL	Logic eXclusive OR
JBC	Jump if bit is set and clear
CPL	Complement bit
INC, DEC	Increment, decrement byte
DJNZ	Decrement and jump if not zero
MOV Px.y, C	Move carry bit to y of port x
CLR Px.y	Clear bit y of port x
SETB Px.y	Set bit y of port x

Table 11.3 Read-modify-write instructions

According to Table 11.1, all Port pins can be configured as Output, Input with the pull-up resistor (around 100 Kohm) or Input. Please refer to the following truth table to know every function setting. When OE=1, this pin is configured as Output. Otherwise OE=0, this pin is configured as Input. User can set PUN=1 or 0 depending on application. When OE=0, PUN=0 is recommended for saving power.

All Port pins can wake A8105 up when WUEN=0 and configured GPIO. All Port pins' WUN signals connect one OR gate to KEYINT. It means pin wake up function needs KEYINT ISR to take care of this interrupt event.

Address/Name	R/W	Bit 7	Bit 6	Bit 5	Bit 4	Bit 3	Bit 2	Bit 1	Bit 0
D1h P0OE	R/W								
Reset		0	0	0	0	0	0	0	0

Port 0 Output Enable Register

Address/Name	R/W	Bit 7	Bit 6	Bit 5	Bit 4	Bit 3	Bit 2	Bit 1	Bit 0
D2h P0PUN	R/W								
Reset		0	0	0	0	0	0	0	0

Port 0 Pull Up Register

Address/Name	R/W	Bit 7	Bit 6	Bit 5	Bit 4	Bit 3	Bit 2	Bit 1	Bit 0
D3h P0WUN	R/W								
Reset		1	1	1	1	1	1	1	1

Port 0 Wake Up Enable Register

Address/Name	R/W	Bit 7	Bit 6	Bit 5	Bit 4	Bit 3	Bit 2	Bit 1	Bit 0
D9h P1OE	R/W								
Reset		0	0	0	0	0	0	0	0

Port 1 Output Enable Register

Address/Name	R/W	Bit 7	Bit 6	Bit 5	Bit 4	Bit 3	Bit 2	Bit 1	Bit 0
DAh P1PUN	R/W								
Reset		0	0	0	0	0	0	0	0

Port 1 Pull Up Register

Address/Name	R/W	Bit 7	Bit 6	Bit 5	Bit 4	Bit 3	Bit 2	Bit 1	Bit 0
DBh P1WUN	R/W								
Reset		1	1	1	1	1	1	1	1

Port 1 Wake Up Enable Register

Address/Name	R/W	Bit 7	Bit 6	Bit 5	Bit 4	Bit 3	Bit 2	Bit 1	Bit 0
A1h P2OE	R/W								
Reset		0	0	0	0	0	0	0	0

Port 2 Output Enable Register

Address/Name	R/W	Bit 7	Bit 6	Bit 5	Bit 4	Bit 3	Bit 2	Bit 1	Bit 0
A2h P2PUN	R/W								
Reset		0	0	0	0	0	0	0	0

Port 2 Pull Up Register

Address/Name	R/W	Bit 7	Bit 6	Bit 5	Bit 4	Bit 3	Bit 2	Bit 1	Bit 0
A3h P2WUN	R/W								
Reset		1	1	1	1	1	1	1	1

Port 2 Wake Up Enable Register

Address/Name	R/W	Bit 7	Bit 6	Bit 5	Bit 4	Bit 3	Bit 2	Bit 1	Bit 0
E1h P3OE	R/W								
Reset		0	0	0	0	0	0	0	0

Port 3 Output Enable Register

Address/Name	R/W	Bit 7	Bit 6	Bit 5	Bit 4	Bit 3	Bit 2	Bit 1	Bit 0
E2h P3PUN	R/W								
Reset		0	0	0	0	0	0	0	0

Port 3 Pull Up Register

Address/Name	R/W	Bit 7	Bit 6	Bit 5	Bit 4	Bit 3	Bit 2	Bit 1	Bit 0
E3h P3WUN	R/W								
Reset		1	1	1	1	1	1	1	1

Port 3 Wake Up Enable Register

IOSEL Register (0xBB)

Address/Name	R/W	Bit 7	Bit 6	Bit 5	Bit 4	Bit 3	Bit 2	Bit 1	Bit 0
BBh IOSEL	R/W	-	RADCIO[1:0]	RTCIO	BBIOS	-	I2CIO	URTIO	
Reset		0	0	0	0	0	0	0	0

RADCIO1 (RC-ADC1 I/O select)

[0]: Disable RC-ADC1 analog input.

[1]: P1.0, P1.1, P1.2, P1.3 are selected for RC-ADC0 analog input pin.

RADCIO0 (RC-ADC0 I/O select)

[0]: Disable RC-ADC0 analog input.

[1]: P0.0, P0.1, P0.2, P0.3 are selected for RC-ADC0 analog input pin.

RTCIO (Real-time clock I/O select)

[1]: The pad is for RTC clock

[0]: The pad is normal I/O

BBIOS (Base band I/O select)

[1]: P0.7, P1.2, P1.3 are selected for RF GPIO1,GPIO2,CKO function pin

[0]: P0.7, P1.2, P1.3 are normal I/O

I2CIO (I2C I/O select)

[1]: The pad is selected for I2C (open drain I/O)

[0]: The pad is normal I/O

URTIO (UART0 I/O select)

[1]: Port 3.0 and Port3.1 are selected for UART0 mode0 (open drain I/O)

[0]: Port 3.0 and Port3.1 are normal I/O

ADCCH Register (0xBC)

Address/Name	R/W	Bit 7	Bit 6	Bit 5	Bit 4	Bit 3	Bit 2	Bit 1	Bit 0
BCh ADCCH	R/W	--	--	--	--	ADCCH3	ADCCH2	ADCCH1	ADCCH0
Reset		0	0	0	0	0	0	0	0

ADCCH[3:1] (ADC I/O select)

[000]: Select P3.2 as ADC analog input.

[001]: Select P3.3 as ADC analog input.

[010]: Select P3.4 as ADC analog input.

[011]: Select P3.5 as ADC analog input.

[100]: Select P1.6 as ADC analog input.

[101]: Select P1.7 as ADC analog input.

[110]: Select P3.0 as ADC analog input.

[111]: Select P3.1 as ADC analog input.

ADCCH0

[1]: Enable ADC analog input

[0]: Disable ADC analog input

11.2 Key interrupt

User can use P0, P1 or P3 port as key input and meanwhile these key are clicked to event a key interrupt to wake up A8105 or enter key process flow. It is a helpful use to design a remote controller and low power consumption with power saving mode setting. The KEY INT vector is located on 0x5B. User can put an interrupt service routine in 0x5B.

The KEY interrupts can wake up A8105 back to normal mode in PM1 and PM2. In PM3, Port 3.2~Port 3.5 and RESETN PIN will reset A8105 and A8105 need to initial all needed peripherals and take care key interrupt event.

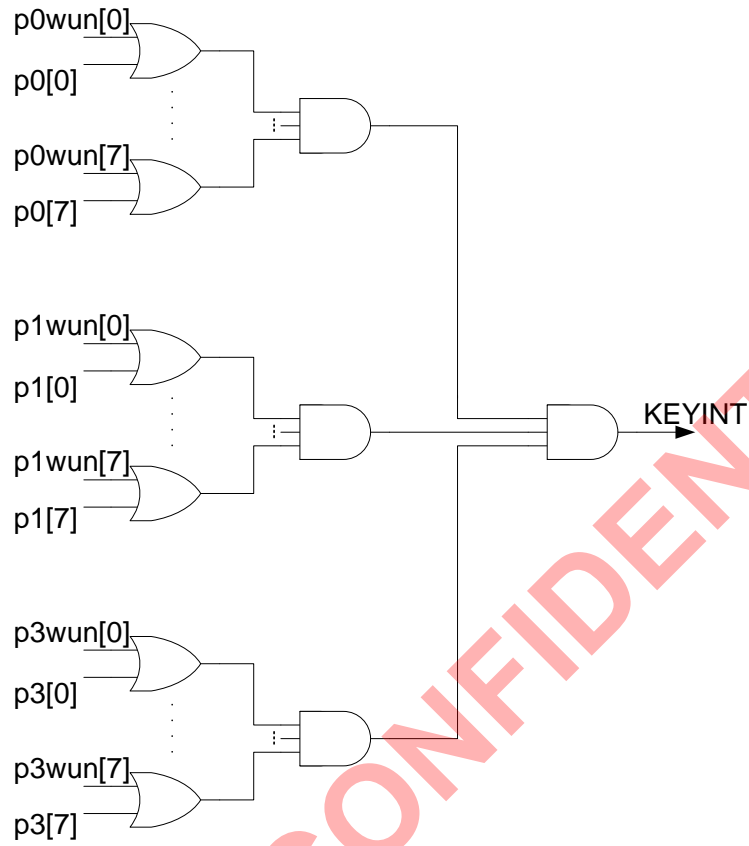

Figure11.2 Key interrupt block diagram

AMICCOM CONFIDENTIAL

12 Timer0,1 and Timer2

A8105 contains three 16-bit timer/counters, Timer 0, Timer 1 and Timer 2. Timer 0 and Timer 1 in the “timer mode”, timer registers are incremented every 4/12/CLK periods depends on CKCON (0x8E) setting, when appropriate timer is enabled. In the “counter mode” the timer registers are incremented every falling transition on their corresponding input pins: T0 or T1. The input pins are sampled every CLK period.

The Timer 2 is one of the most powerful peripheral units of the core. It can be used for all kinds of digital signal generation and event capturing like pulse generation, pulse width modulation, pulse width measuring etc.

12.1 Timer 0 & 1 PINS DESCRIPTION

The pins functionality is described in the following table. All pins are one directional.

PIN	ACTIVE	TYPE	DESCRIPTION
T0(P3.4)	Falling	Input	Timer 0 clock line
GATE0(P3.2)	High	Input	Timer 0 clock line gate control
T1(P3.5)	Falling	Input	Timer 1 clock line
GATE1(P3.3)	High	Input	Timer 1 clock line gate control

Table12.1 Timer 0, 1 pins description

12.2 Timer 0 & 1 FUNCTIONALITY

12.2.1 OVERVIEW

Timer 0 and Timer 1 are fully compatible with the standard 8051 timers. Each timer consists of two 8-bit registers TH0 (0x8C), TL0 (0x8A), TH1 (0x8D), TL1 (0x8B). Timers 0, 1 work in the same four modes. The modes are described below.

M1	M0	Mode	Function description
0	0	0	THx operates as 8-bit timer/counter with a divide by 32 prescaler served by lower 5-bit of TLx.
0	1	1	16-bit timer/counter. THx and TLx are cascaded.
1	0	2	TLx operates as 8-bit timer/counter with 8-bit auto-reload by THx.
1	1	3	TL0 is configured as 8-bit timer/counter controlled by the standard Timer 0 bits. TH0 is an 8-bit timer controlled by the Timer 1 controls bits. Timer 1 holds its count.

Table12.2 Timer 0 and 1 modes

12.2.2 Timer 0 & 1 Registers

TMOD register (0x89)

Address/Name	R/W	Bit 7	Bit 6	Bit 5	Bit 4	Bit 3	Bit 2	Bit 1	Bit 0
89h TMOD	R/W	GATE1	CT	M1	M0	GATE0	CT	M1	M0
		Timer 1 control bits				Timer 0 control bits			
Reset		0	0	0	0	0	0	0	0

GATE : Gating control

=1, Timer x enabled while GATEx pin is high and TRx control bit is set.

=0, Timer x enabled while TRx control bit is set.

CT : Counter or timer select bit

=1, Counter mode, Timer x clock from Tx pin.

=0, Timer mode, internally clocked.

M[1 : 0] : Mode select bits

TCON register (0x88)

Address/Name	R/W	Bit 7	Bit 6	Bit 5	Bit 4	Bit 3	Bit 2	Bit 1	Bit 0
88h TCON	R/W	TF1	TR1	TF0	TR0	IE1	IT1	IE0	IT0
Reset		0	0	0	0	0	0	0	0

TR0 : Timer 0 run control bit

=1, enabled.

=0, disabled.

TR1 : Timer 1 run control bit

=1, enabled.
=0, disabled.

TF0 : Timer 0 interrupt (overflow) flag.

Cleared by hardware when processor branches to interrupt routine.

TF1 : Timer 1 interrupt (overflow) flag.

Cleared by hardware when processor branches to interrupt routine.

CKCON register (0x8E)

Address/Name	R/W	Bit 7	Bit 6	Bit 5	Bit 4	Bit 3	Bit 2	Bit 1	Bit 0
8Eh CKCON	R/W	WD1	WD0	T2M	T1M	T0M	MD2	MD1	MD0
Reset		0	0	0	0	0	0	0	0

T2M : This bit controls the division of the system clock that drives Timer 2.

=1, Timer 2 uses a divided-by-4 of the system clock frequency.

=0, Timer 2 uses a divided-by-12 of the system clock frequency.

T1M : This bit controls the division of the system clock that drives Timer 1.

=1, Timer 1 uses a divided-by-4 of the system clock frequency.

=0, Timer 1 uses a divided-by-12 of the system clock frequency.

T0M : This bit controls the division of the system clock that drives Timer 0.

=1, Timer 0 uses a divided-by-4 of the system clock frequency.

=0, Timer 0 uses a divided-by-12 of the system clock frequency.

IE register (0xA8)

Address/Name	R/W	Bit 7	Bit 6	Bit 5	Bit 4	Bit 3	Bit 2	Bit 1	Bit 0
A8h IE	R/W	EA	-	ET2	ES	ET1	EX1	ET0	EX0
Reset		0	0	0	0	0	0	0	0

EA : Enable global interrupts.

ET0 : Enable Timer 0 interrupts.

ET1 : Enable Timer 1 interrupts.

IP register (0xB8)

Address/Name	R/W	Bit 7	Bit 6	Bit 5	Bit 4	Bit 3	Bit 2	Bit 1	Bit 0
B8h IP	R/W	-	-	PT2	PS	PT1	PX1	PT0	PX0
Reset		0	0	0	0	0	0	0	0

PT0 : Timer 0 priority level control (at 1-high level)

PT1 : Timer 1 priority level control (at 1-high level)

Timer 0, 1 related bits that generate interrupts can be set or cleared by software, with the same result as if they had been set or cleared by hardware. That is, interrupts can be generated or pending interrupts can be cancelled by software.

Interrupt flag	Function	Active level/edge	Flag resets	Vector	Natural priority
TF0	Internal, Timer 0	-	Hardware	0x0B	2
TF1	Internal, Timer 1	-	Hardware	0x1B	4

Table12.3 Timer 0, 1 interrupts

12.2.3 Timer 0 – Mode 0

In this mode, the Timer 0 register is configured as a 13-bit register. As the count rolls over from all 1s to all 0s, Timer 0 interrupt flag TF0 is set. The counted input is enabled to the Timer 0 when TCON.4 = 1 and either TMOD.3 = 1 or GATE0 = 1. (Setting TMOD.3 = 1 allows the Timer 0 to be controlled by external input GATE0, to facilitate pulse width measurement). The 13-bit register consists of all 8-bit of TH0 and lower 5 bits of TL0. The upper 3 bits of TL0 are indeterminate and should be ignored.

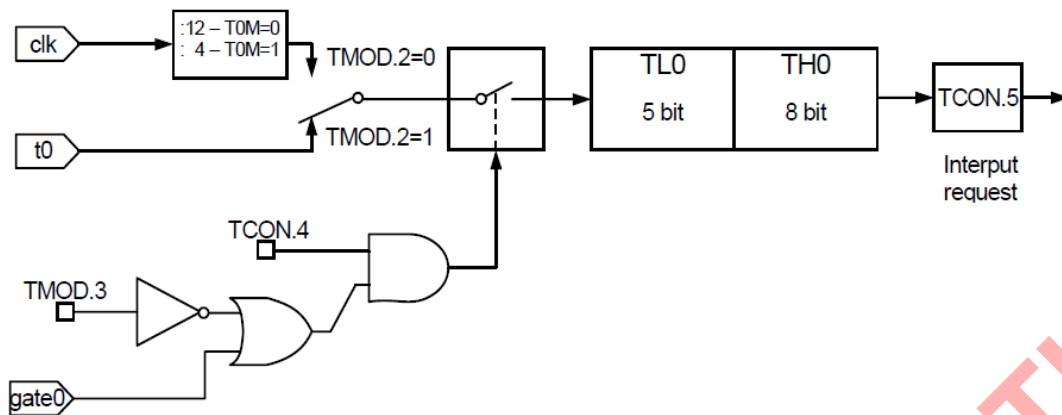

Figure 12.1 Timer/Counter 0, Mode 0 : 13-Bit Timer/Counter

12.2.4 Timer 0 – Mode 1

Mode 1 is the same as Mode 0, except that the timer register is running with all 16 bits. Mode 1 is shown in figure below.

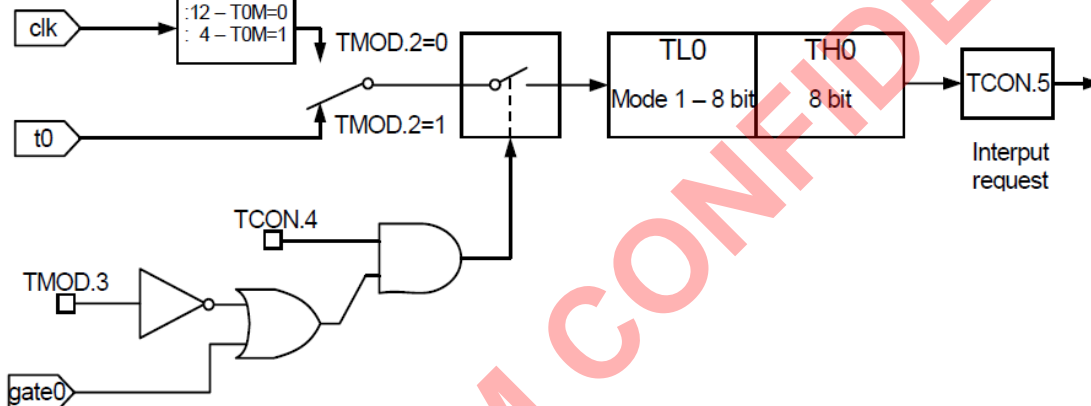

Figure 12.2 Timer/Counter 0, Mode 1 : 16-Bit Timer/Counter

12.2.5 Timer 0 – Mode 2

Mode 2 configures the timer register as an 8-bit counter (TL0) with automatic reloads, as shown in figure below. Overflow from TL0 not only sets TF0, but also reloads TL0 with the contents of TH0, which is loaded by software. The reload leaves TH0 unchanged.

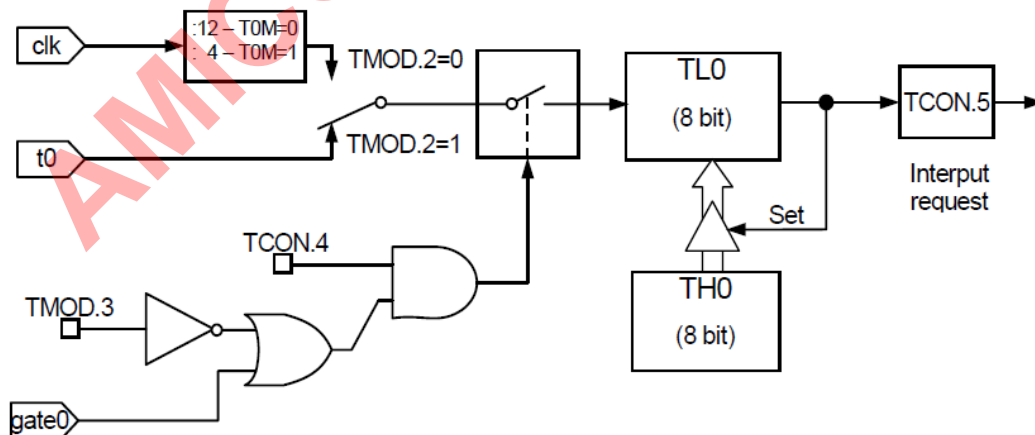

Figure 12.3 Timer/Counter 0, Mode 2 : 8-Bit Timer/Counter with Auto-Reload

12.2.6 Timer 0 – Mode 3

Timer 0 in Mode 3 establishes TL0 and TH0 as two separate counters. The logic for Mode 3 on Timer 0 is shown in figure below. TL0 uses the Timer 0 control bits : C/T, GATE, TR0, GATE0 and TF0. TH0 is locked into a timer function and use the TR1 and TF1 flag from Timer1 and controls Timer1 interrupt. Mode 3 is provided for applications requiring an extra 8-bit timer/counter. When Timer 0 is in Mode 3, Timer 1 can be turned off by switching it into its own Mode 3, or can still be used by the serial channel as a baud rate generator, or in any application where interrupt from Timer 1 is not required.

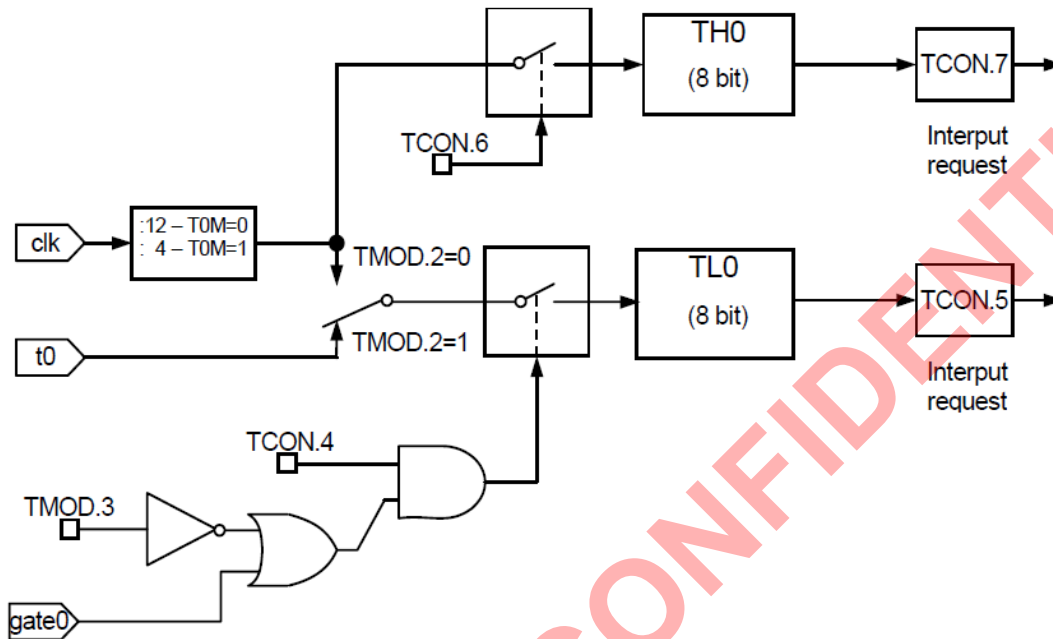

Figure12.4 Timer/Counter 0, Mode 3 : Two 8-Bit Timers/Counters

12.2.7 Timer 1 – Mode 0

In this Mode, the Timer1 register is configured as a 13-bit register. As the count rolls over from all 1s to all 0s, Timer1 interrupt flag TF1 is set. The counted input is enabled to the Timer1 when TCON.6 = 1 and either TMOD.6 = 0 or GATE1 = 1. (Setting TMOD.7 = 1 allows the Timer1 to be controlled by external input GATE1, to facilitate pulse width measurements). The 13-bit register consists of all 8 bits of TH1 and the lower 5 bits of TL1. The upper 3 bits of TL1 are indeterminate and should be ignored.

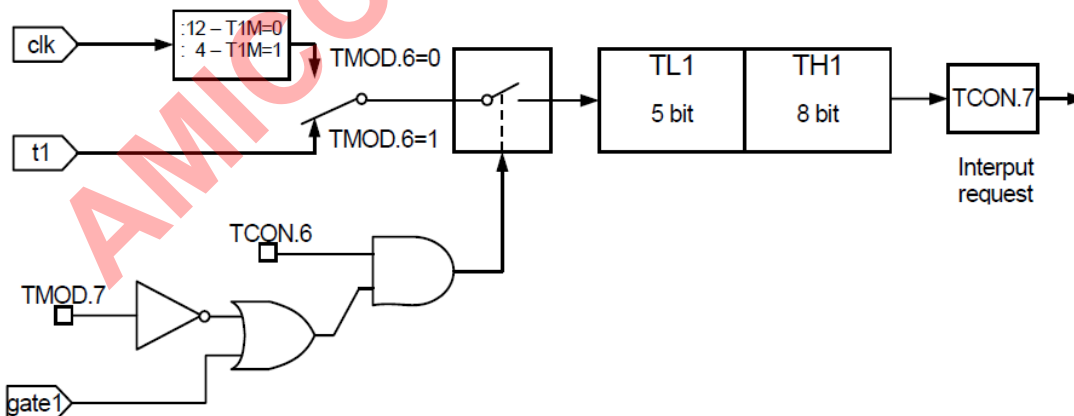

Figure12.5 Timer/Counter 1, Mode 0 : 13-Bit Timers/Counters

12.2.8 Timer 1 – Mode 1

Mode 1 is the same as Mode 0, except that timer register is running with all 16 bits. Mode 1 is shown in figure below.

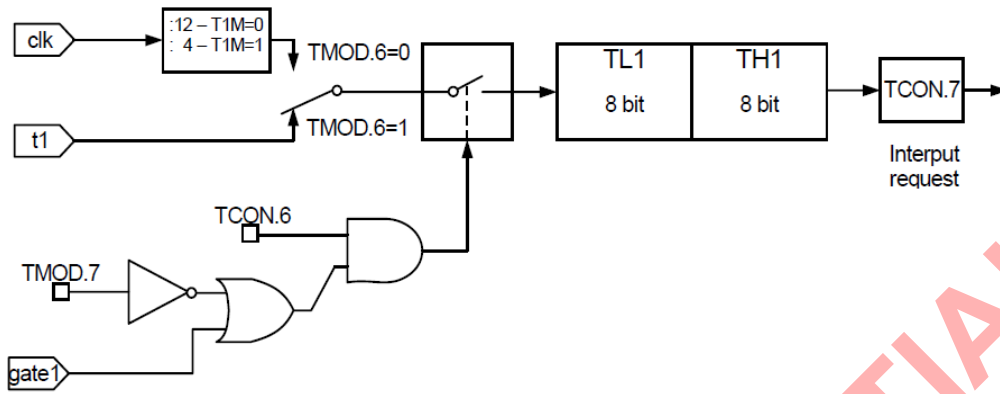

Figure12.6 Timer/Counter 1, Mode 0 : 16-Bit Timers/Counter

12.2.9 Timer 1 – Mode 2

Mode 2 configures the timer register as an 8-bit counter (TL1) with automatic reloads, as shown in figure below. Overflow from TL1 not only sets TF1, but also reloads TL1 with the contents of TH1, which is loaded by software. The reload leaves TH1 unchanged.

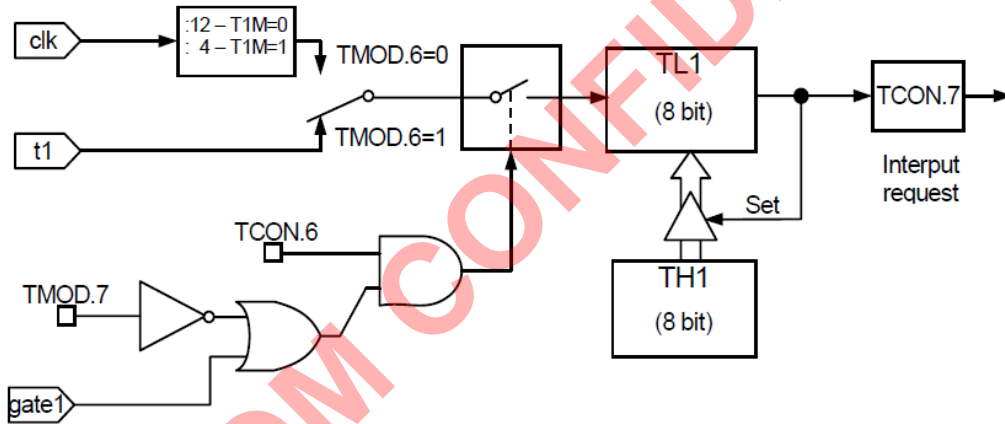

Figure12.7 Timer/Counter 1, Mode 2 : 8-Bit Timer/Counter with Auto-Reload

12.2.10 Timer 1 – Mode 3

Timer 1 in Mode 3 is held counting. The effect is the same as setting TR1=0.

12.3 Timer2 PINS DESCRIPTION

The Timer 2 pins functionality is described in the following table. All pins are one directional.

PIN	ACTIVE	TYPE	DESCRIPTION
t2(P1.0)	falling	INPUT	Timer 2 clock line
t2ex(P1.1)	high	INPUT	Timer 2 control

Table12.4 Compare/Capture pins description

12.4 Timer2 FUNCTIONALITY

12.4.1 OVERVIEW

Timer 2 is fully compatible with the standard 8052 Timer 2. It is up counter. Totally five SFRs control the Timer 2 operation: TH2/TL2(0xCD/0xCC) counter registers, RCAP2H/RCAP2L (0xCB/0xCA) capture registers and T2CON(0xC8) control register. Timer 2 works in the three modes selected by T2CON bits as shown in table below.

RCLK,	CPRL2	TR2	Function description
-------	-------	-----	----------------------

TCLK			
0	0	1	16-bit auto-reload mode. The Timer 2 overflow sets TF2 bit and the TH2, TL2 registers reloaded 16-bit value from RCAP2H, RCAP2L.
0	1	1	16-bit capture mode. The Timer 2 overflow sets TF2 bit. When the EXEN2 = 1, the TH2, TL2 register values are stored into RCAP2H, RCAP2L while falling edge is detected on T2EX pin.
1	X	1	Baud rate generator for the UART0 interface. It auto-reloads its counter with RCAP2H, RCAP2L values each overflows.
X	X	0	Timer 2 is off

Table 12.5

Timer 2 modes

12.4.2 Timer 2 Registers

T2CON register (0xC8)

Address/Name	R/W	Bit 7	Bit 6	Bit 5	Bit 4	Bit 3	Bit 2	Bit 1	Bit 0
C8h	R/W	TF2	EXF2	RCLK	TCLK	EXEN2	TR2	CT2	CPRL2
APOL		0	0	0	0	0	0	0	0
Reset		0	0	0	0	0	0	0	0

EXF2 : Falling edge indicator on T2EX pin when EXEN = 1. Must be cleared by software.

RCLK : Receiver clock enable

- =1, UART0 receiver is clocked by Timer 2 overflow pulses
- =0, UART0 receiver is clocked by Timer 2 overflow pulses

TCLK : Transmit clock enable

- =1, UART0 transmitter is clocked by Timer 2 overflow pulses
- =0, UART0 transmitter is clocked by Timer 2 overflow pulses

EXEN2 : Enable T2EX pin functionality.

- =1, Allows capture or reload as a result of T2EX pin falling edge.
- =0, ignore T2EX events

TR2 : Start / Stop Timer 2

- =1, start
- =0, stop

CT2 : Timer / counter select

- =1, external event counter. Clock source is T2 pin.
- =0, timer 2 internally clocked

CPRL2 : Capture / Reload select

- =1, T2EX pin falling edge causes capture to occur when EXEN2 = 1
- =0, automatic reload occurs on Timer 2 overflow or falling edge T2EX pin when EXEN2 = 1. When RCLK or TCLK is set this bit is ignored and automatic reload on Timer 2 overflow is forced.

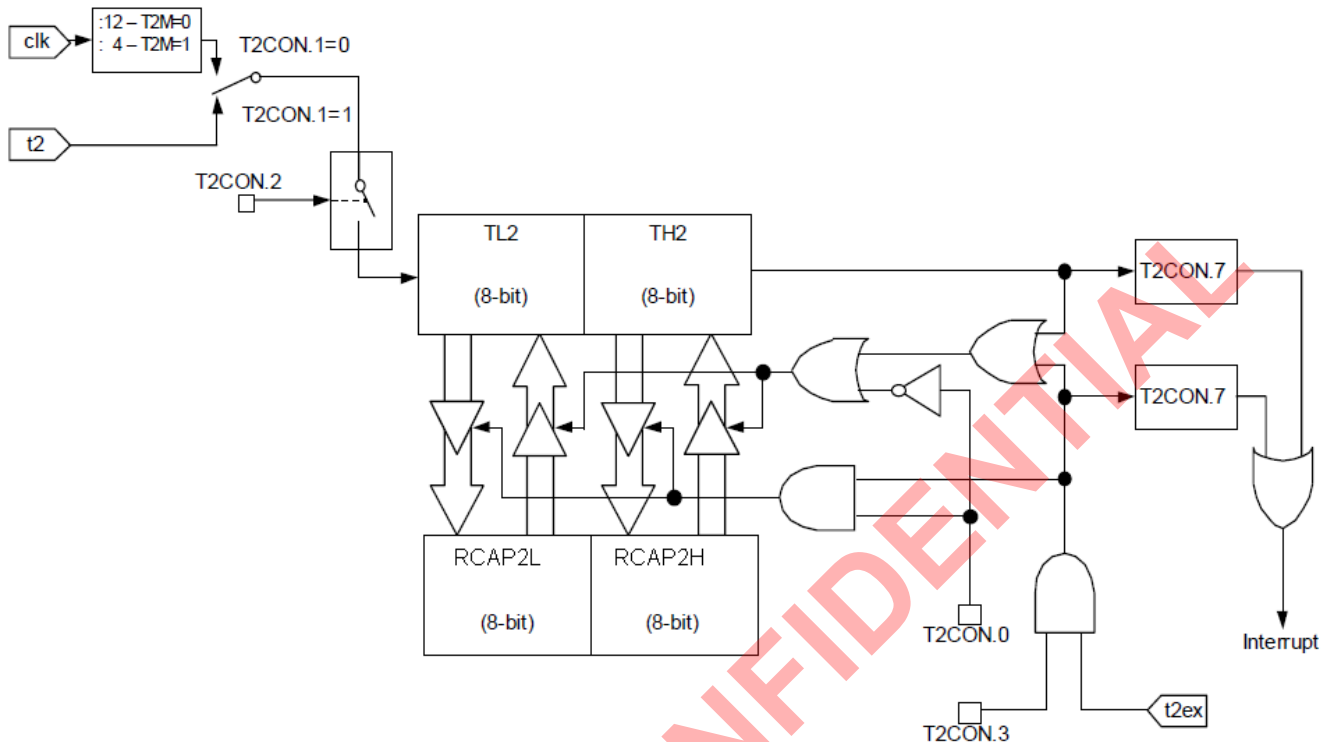

Figure 12.8 Timer 2 block diagram in timer mode

CKCON register (0x8E)

Address/Name	R/W	Bit 7	Bit 6	Bit 5	Bit 4	Bit 3	Bit 2	Bit 1	Bit 0
8Eh CKCON	R/W	WD1	WD0	T2M	T1M	T0M	MD2	MD1	MD0
Reset		0	0	0	0	0	0	0	0

T2M : This bit controls the division of the system clock that drives Timer 2. This bit has no effect when the timer is in baud rate generator mode.

=1, Timer 2 uses a divide-by-4 of the system clock frequency.

=0, Timer 2 uses a divide-by-12 of the system clock frequency.

Timer 2 interrupt related bits are shown below. An interrupt can be turned on/off by IE (0xA8) register, and set into high/low priority group by IP register.

IE register (0xA8)

Address/Name	R/W	Bit 7	Bit 6	Bit 5	Bit 4	Bit 3	Bit 2	Bit 1	Bit 0
A8h IE	R/W	EA	-	ET2	ES	ET1	EX1	ET0	EX0
Reset		0	0	0	0	0	0	0	0

EA : Enable global interrupts.

ET2 : Enable Timer 2 interrupts.

IP register (0xB8)

Address/Name	R/W	Bit 7	Bit 6	Bit 5	Bit 4	Bit 3	Bit 2	Bit 1	Bit 0
B8h IP	R/W	-	-	PT2	PS	PT1	PX1	PT0	PX0
Reset		0	0	0	0	0	0	0	0

PT2 : Timer 2 priority level control (at 1-high level)

T2CON register (0xC8)

Address/Name	R/W	Bit 7	Bit 6	Bit 5	Bit 4	Bit 3	Bit 2	Bit 1	Bit 0
C8h T2CON Reset	R/W	TF2	EXF2	RCLK	TCLK	EXEN2	TR2	CT2	CPRL2
		0	0	0	0	0	0	0	0

TF2 : Timer 2 interrupt (overflow) flag. It must be cleared by software.
The flag will not be set when either RCLK or TCLK is set.

All Timer 2 related bits generate interrupts can be set or cleared by software, with the same result as if they had been set or cleared by hardware. That is, interrupts can be generated or pending interrupts can be cancelled by software.

Interrupt flag	Function	Active level / edge	Flag resets	Vector	Natural priority
TF2	Internal, Timer2	-	Software	0x2B	6

Table12.6 Timer2 interrupt

Interrupt is also generated at falling edge of T2EX pin, while EXEN2 bit is set. This interrupt doesn't set TF2 flag, but EXF2 only and also uses 0x2B vector. Please see picture below. Timer2 internal logic configured as baud-rate generator is shown below.

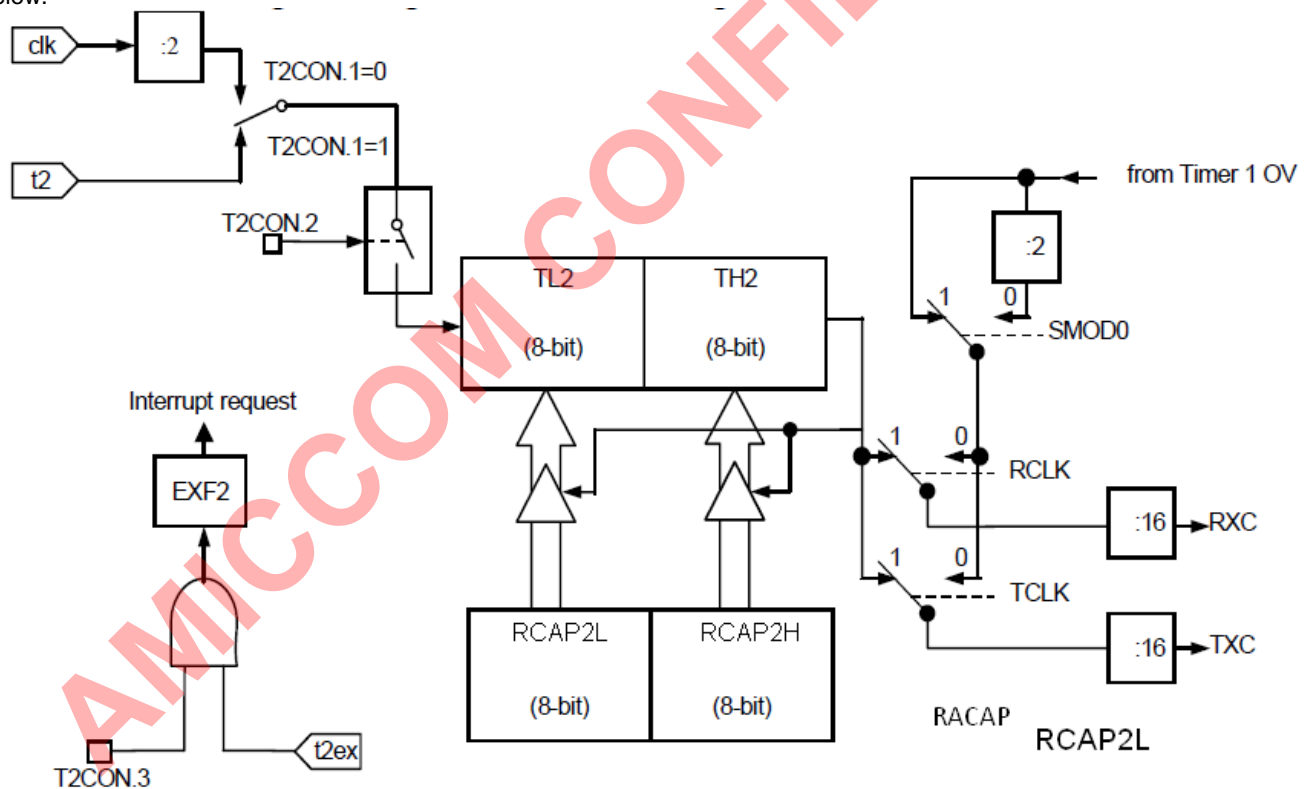

Figure12.9 Timer 2 block diagram as UART0 baud rate generator

Please note that SMODbit is ignored by UART when clocked by Timer2. The RCLK/TCLK frequency is equal to :

$$xCLK = \frac{CLK}{2 \cdot (65536 - RLD)}$$

where $xCLK = TCLK, RCLK$

13. UART

UART is full duplex, meaning it can transmit and receive concurrently. It is receive double-buffered, meaning it can commence reception of a second byte before a previously received byte has been read from the receive register. Writing to SBUF loads the transmit register, and reading SBUF reads a physically separate receive register. The serial port can operate in 4 modes: one synchronous and three asynchronous modes. Mode 2 and 3 has a special feature for multiprocessor communications. This feature is enabled by setting SM2 bit in SCON register. The master processor first sends out an address byte, which identifies the target slave. An address byte differs from a data byte in that the 9th bit is 1 in an address byte and 0 in a data byte. With SM2 = 1, no slave will be interrupted by a data byte. An address byte will interrupt all slaves. The addressed slave will clear its SM2 bit and prepare to receive the data bytes that will be coming. The slaves that were not being addressed leave their SM2 set and ignoring the incoming data.

13.1 UART PINS DESCRIPTION

The UART pins functionality is described in the following table. All pins are one directional. There are no three-state output pins and internal signals.

PIN	ACTIVE	TYPE	DESCRIPTION
Rxd_0(P3.0)	-	Input / Output	Serial receiver I/O / O_0
Txd_0(P3.1)	-	Output	Serial transmitter line 0

Table13.1 UART pins description

13.2 FUNCTIONALITY

The UART has the same functionality as a standard 8051 UART. The UART related registers are: SBUF(0x99), SCON (0x98), PCON(0x87), IE(0xA8) and IP(0xB8). The UART data buffer (SBUF) consists of two separate registers: transmit and receive registers. A data writes into the SBUF sets this data in UART output register and starts a transmission. A data reads from SBUF, reads data from the UART receive register.

SBUF register (0x99)

Address/Name	R/W	Bit 7	Bit 6	Bit 5	Bit 4	Bit 3	Bit 2	Bit 1	Bit 0
99h SBUF	R/W								
Reset		0	0	0	0	0	0	0	0

SBUF[7:0] : UART buffer

SCON register (0x98)

Address/Name	R/W	Bit 7	Bit 6	Bit 5	Bit 4	Bit 3	Bit 2	Bit 1	Bit 0
98h SCON	R/W	SM00	SM01	SM02	REN	TB8	RB8	TI	RI
Reset		0	0	0	0	0	0	0	0

SM2 : Enable a multiprocessor communication feature

SM [1:0] : Sets baud rate

SM0	SM1	Mode	Description	Baud Rate
0	0	0	Shift register	$F_{CLK}/12$
0	1	1	8-bit UART	Variable
1	0	2	9-bit UART	$F_{CLK}/32$ or $F_{CLK}/64$
1	1	3	9-bit UART	Variable

Timer 2 cannot be used as baud rate generator when Compare Capture unit is present in the system. The UART baud rates are presented in the table below.

Mode	Baud Rate
Mode 0	$F_{CLK}/12$

Mode 1, 3 Timer 1 overflow rate – $T1_{ov}$
 SMOD= 0 $T1_{ov}/32$
 SMOD= 1 $T1_{ov}/16$
 Timer 2 overflow rate – $T2_{ov}$
 SMOD= x $T2_{ov}/16$
 Mode 2 SMOD= 0 $F_{CLK}/64$
 SMOD= 1 $F_{CLK}/32$

The SMOD bit is located in PCON register.

REN : If set, enable serial reception. Cleared by software to disable reception.

TB8 : The 9th transmitted data bit in Modes 2 and 3. Set or cleared by the MCU, depending on the function it performs (parity check, multiprocessor communication etc.)

RB8 : In Modes 2 and 3 it is the 9th data bit received. In Mode 1, if SM2 is 0, RB8 is the stop bit. In Mode 0 this bit is not used.

PCON register (0x87)

Address/Name	R/W	Bit 7	Bit 6	Bit 5	Bit 4	Bit 3	Bit 2	Bit 1	Bit 0
87h PCON	R/W	SMOD	-	-	PWE	-	SWB	STOP	CKSE
Reset		0	0	0	0	0	0	0	0

SMOD : UART double baud rate bit when clocked by Timer 1 only.

UART interrupt related bits are shown below. An interrupt can be turned on / off by IE register, and set into high / low priority group by IP register.

IE register (0xA8)

Address/Name	R/W	Bit 7	Bit 6	Bit 5	Bit 4	Bit 3	Bit 2	Bit 1	Bit 0
A8h IE	R/W	EA	-	ET2	ES	ET1	EX1	ET0	EX0
Reset		0	0	0	0	0	0	0	0

ES : RI & TI interrupt enable flag

IP register (0xB8)

Address/Name	R/W	Bit 7	Bit 6	Bit 5	Bit 4	Bit 3	Bit 2	Bit 1	Bit 0
B8h IP	R/W	-	-	PT2	PS	PT1	PX1	PT0	PX0
Reset		0	0	0	0	0	0	0	0

PS : RI & TI interrupt priority flag

SCON register (0x98)

Address/Name	R/W	Bit 7	Bit 6	Bit 5	Bit 4	Bit 3	Bit 2	Bit 1	Bit 0
98h SCON	R/W	SM0	SM1	SM2	REN	TB8	RB8	TI	RI
Reset		0	0	0	0	0	0	0	0

TI : Transmit interrupt flag, set by hardware after completion of a serial transfer. It must be cleared by software.

RI : Receive interrupt flag, set by hardware after completion of a serial reception. It must be cleared by software.

All of bits that generate interrupts can be set or cleared by software, with the same result as if they had been set or cleared by hardware. That is, interrupts can be generated or pending interrupts can be cancelled by software.

Interrupt flag	Function	Active level / edge	Flag resets	Vector	Natural priority
TI & RI	Internal, UART	-	Software	0x23	5

Table13.3

UART interrupt

13.3 OPERATING MODES

13.3.1 UART MODE 0, SYNCHRONOUS

Pin RXD0I serves as input and RXD0O as output. TXD0 output is a shift clock. The baud rate is fixed at 1/12 of the CLK clock frequency. Eight bits are transmitted with LSB first. Reception is initialized by setting the flags in SCON as follows: RI=0 and REN=1.

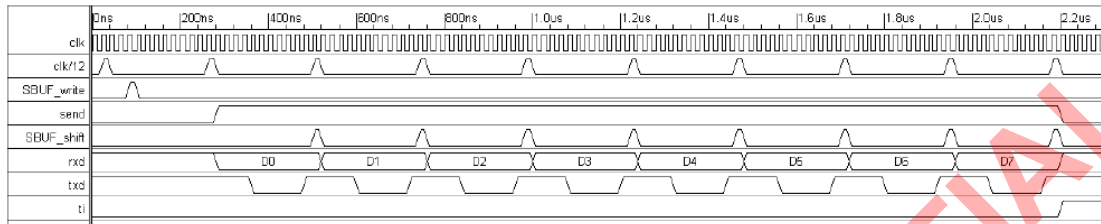

Figure13.3 UART transmission mode 0 timing diagram

13.3.2 UART MODE 1, 8-BIT UART, VARIABLE BAUD RATE, TIMER CLOCK SOURCE

Pin RXD0I serves as input, and TXD0 serves as serial output. 10 bits are transmitted: a start bit (always 0), 8 data bits (LSB first), and a stop bit (always 1). On receive, a start bit synchronizes the transmission, 8 data bits are available by reading SBUF, and stop bit sets the flag RB8 in the SFR SCON. The baud rate is variable and depends from Timer 1 or Timer 2 mode. To enable Timer 2 clocking set the TCLK, RCLK bits located in T2CON (0xC8) register. SMOD bit is ignored when UART is clocked by Timer2.

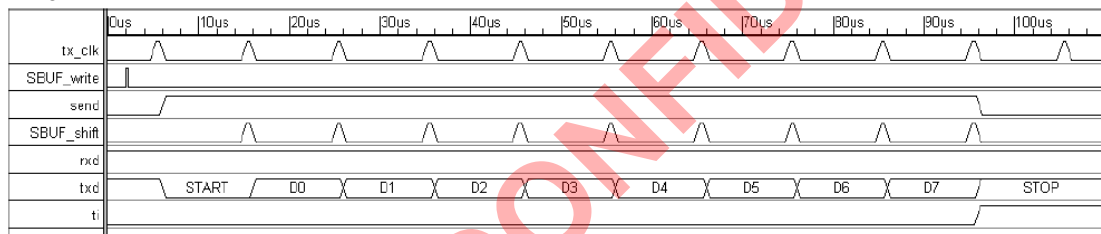

Figure13.4 UART transmission mode 1 timing diagram

13.3.3 UART MODE 2, 9-BIT UART, FIXED BAUD RATE

This mode is similar to Mode 1 with two differences. The baud rate is fixed at 1/32 or 1/64 of CLK clock frequency, and 11 bits are transmitted or received: a start bit (0), 8 data bits (LSB first), a programmable 9th bit, and a stop bit (1). The 9th bit can be used to control the parity of the UART interface: at transmission, bit TB8 in SCON is output as the 9th bit, and at receive, the 9th bit affects RB8 in SCON.

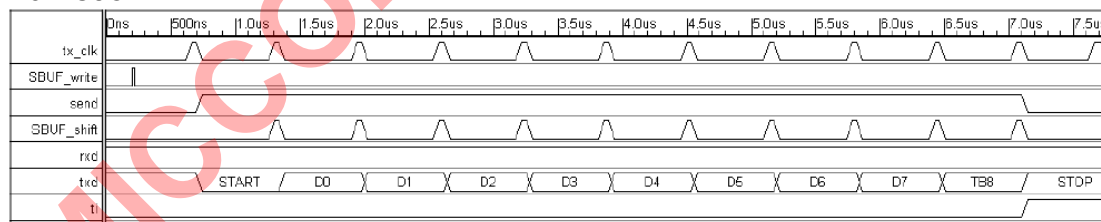

Figure13.5 UART transmission mode 2 timing diagram

13.3.4 UART MODE 3, 9-BIT UART, VARIABLE BAUD RATE, TIMER CLOCK SOURCE

The only difference between Mode 2 and Mode 3 is that the baud rate is a variable in Mode 3. When REN=1 data receiving is enabled. The baud rate is variable and depends from Timer 1 or Timer 2 mode. To enable Timer 2 clocking set the TCLK, RCLK bits located in T2CON (0xC8) register. SMOD bit is ignored when UART is clocked by Timer2.

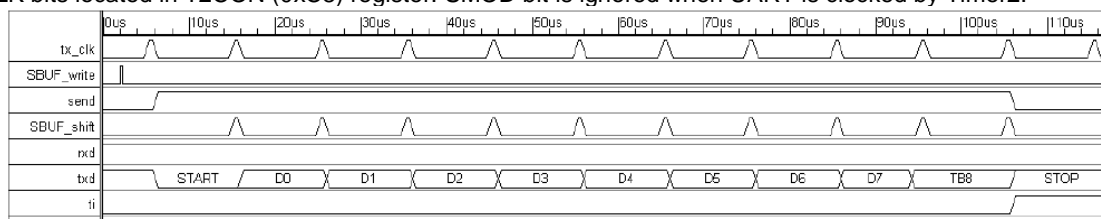

Figure13.6 UART transmission mode 3 timing diagram

14. IIC interface

A8105's I²C peripheral provides two-wire interface between the device and I²C -compatible device by the two-wire I²C serial bus. The I²C peripheral supports the following functions.

- Conforms to v2.1 of the I²C specification (published by Philips Semiconductor)
- Master transmitter / receiver
- Slave transmitter / receiver
- Flexible transmission speed modes: Standard (up to 100 Kb/s) and Fast (up to 400Kb/s)
- Multi-master systems supported
- Supports 7-bit addressing modes on the I²C bus
- Interrupt generation
- Allows operation from a wide range of input clock frequencies (build-in 8-bit timer)

PIN 23 and PIN 24 are I2C Interface in A8105. The alternate function is Port 0.5 and Port 0.6. User can set BBSEL (BBH) to set up the PIN function. Please refer the Chapter 11 for more detail information.

PIN	TYPE	DESCRIPTION
SCL(P0.5)	INPUT /OUTPUT	I ² C clock input /output
SDA(P0.6)	INPUT/ OUTPUT	I ² C data input /output

Table14.1 I2C interface pins description

14.1 Master mode I²C

The I²C master mode provides an interface between a microprocessor and an I²C bus. It can be programmed to operate with arbitration and clock synchronization to allow it to operate in multi -master systems. Master mode I²C supports transmission speeds up to 400Kb/s.

14.1.1 I²C REGISTERS

There are six registers used to interface to the host: the Control, Status, Slave Address, Transmitted Data, Received Data and Timer Period Register.

Register	Address
Slave address – I2CMSA	0xF4
Control – I2CMCR	0xF5
Transmitted data I2CBUF	0xF6
Timer period - I2CMTP	0xF7

Table14.3 I²C Registers for writing

Register	Address
Slave address – I2CMSA	0xF4
Status – I2CMSR	0xF5
Received data - I2CBUF	0xF6
Timer period - I2CMTP	0xF7

Table14.4 I²C Registers for reading

■ I²C Master mode Timer Period Register

To generate wide range of SCL frequencies the core have built-in 8-bit timer. Programming sequence must be done at least once after system reset. After reset, register have 0x01 value by default.

SCL_PERIOD = 2 x (1+TIMER_PRD) x (SCL_LP + SCL_HP) x CLK_PRD
For example :
- CLK_PRD = 62.5ns (CLK_FRQ = 16MHz) ;
- TIMER_PRD =3 ;
- SCL_LP = 6 ; (fixed)
- SCL_HP = 4; (fixed)
SCL_PERIOD = 2 x (1 + 3) x (6 + 4) x 62.5ns = 5000ns = 5us
SCL_FREQUENCY = 1 / 5us = 200 KHz
SCL_PRD - SCL line period (I2C clock line)
TIMER PRD -Timer period register value (range 1 to 255)

CLK_PRD - System clock period ($1/f_{clk}$)

I2CMTP (0xE7)

Address/Name	R/W	Bit 7	Bit 6	Bit 5	Bit 4	Bit 3	Bit 2	Bit 1	Bit 0
E7h I2CMTP	R/W	0	P.6	P.5	P.4	P.3	P.2	P.1	P.0
Reset		0	0	0	0	0	0	0	1

I²C CONTROL AND STATUS REGISTERS

The Control Register consists of eight bits: the RUN, START, STOP, ACK, HS, ADDR, SLRST and RSTB bit. The RSTB bit performs reset of whole I²C controller and behaves identically as external reset provided by RST pin. Using this bit software application can reinitialize I²C mater module when some problem is encountered on I²C bus. In case when I²C Slave device blocks I²C bus, then SLRST bit should be set along with RUN bit (just after issuing the RSTB). SLRST bit causes that I²C master module generates 9 SCK clocks (no START is generated) to recover Slave device to known state and issues at the end STOP. This bit is automatically cleared by I2C MASTER MODULE, thus, it is always read as '0'. The BUSY bit should be checked to know when this transmission is ended.

The START bit will cause the generation of the START, or REPEATED START condition. The STOP bit determines if the cycle will stop at the end of the data cycle, or continue on to a burst. To generate a single send cycle, the Slave Address register is written with the desired address, the R/S bit is set to '0', and Control Register is written with HS=0, ACK=x, STOP=1, START=1, RUN=1 (binary xxx0x111 x-mean 0 or 1) to perform the operation and stop. When the operation is completed (or aborted due an error), the interrupt is generated. The data may be read from Received Data Register. When I2C MASTER MODULE core operates in Master receiver mode the ACK bit must be set normally to logic 1. This cause the I2C MASTER MODULE bus controller to send acknowledge automatically after each byte. This bit must be reset when the I2C MASTER MODULE bus controller requires no further data to be sent from slave transmitter.

The ADDR bit along with RUN bit cause the generation of the START condition and transmission of Slave Address. Next STOP can end transmission, or REPEATED START generates the START and ADDRESS sequence once again. In both cases STOP can ends transmission. See I²C MASTER MODULE ACK Polling chapter for details.

I2CMCR (0xF5)

Address/Name	R/W	Bit 7	Bit 6	Bit 5	Bit 4	Bit 3	Bit 2	Bit 1	Bit 0
F5h I2CMCR	R/W	RSTB	SLRST	ADDR	HS	ACK	STOP	START	RUN
Reset		0	0	0	0	0	0	0	0

RSTB	SLRST	ADDR	HS	R/S	ACK	STOP	START	RUN	OPERATION
0	0	0	0	0	-	0	1	1	START condition followed by SEND (Master remains in Transmitter mode)
0	0	0	0	0	-	1	1	1	START condition followed by SEND and STOP condition
0	0	0	0	1	0	0	1	1	START condition followed by RECEIVE operation with negative Acknowledge (Master remains in Receiver mode)
0	0	0	0	1	0	1	1	1	START condition followed by RECEIVE and STOP condition
0	0	0	0	1	1	0	1	1	START condition followed by RECEIVE (Master remains in Receiver mode)
0	0	0	0	1	1	1	1	1	forbidden sequence
0	0	0	1	0	0	0	0	1	Master Code sending and switching to High-speed mode
1	0	0	-	-	-	-	-	-	I2CM module software reset
0	1	0	0	0	0	0	0	1	Reset slaves connected to I2C bus by generating 9 SCK clocks followed by STOP
0	0	1	0	0	0	0	0	1	START condition followed by Slave Address

Table14.5 Control bits combinations permitted in IDLE state *

RSTB	SLRST	ADDR	HS	R/S	ACK	STOP	START	RUN	OPERATION
------	-------	------	----	-----	-----	------	-------	-----	-----------

0	0	0	0	-	-	0	0	1	SEND operation (Master remains in Transmitter mode)
0	0	0	0	-	-	1	0	0	STOP condition
0	0	0	0	-	-	1	0	1	SEND followed by STOP condition
0	0	0	0	0	-	0	1	1	Repeated START condition followed by SEND (Master remains in Transmitter mode)
0	0	0	0	0	-	1	1	1	Repeated START condition followed by SEND and STOP condition
0	0	0	0	1	0	0	1	1	Repeated START condition followed by RECEIVE operation with negative Acknowledge (Master remains in Receiver mode)
0	0	0	0	1	0	1	1	1	Repeated START condition followed by SEND and STOP condition
0	0	0	0	1	1	0	1	1	Repeated START condition followed by RECEIVE (Master remains in Receiver mode)
0	0	0	0	1	1	1	1	1	forbidden sequence
1	0	0	-	-	-	-	-	-	I2CM module software reset
0	0	1	0	0	-	0	1	1	Repeated START condition followed by Slave Address

Table14.6 Control bits combinations permitted in Master Transmitter mode

RSTB	SLRST	ADDR	HS	R/S	ACK	STOP	START	RUN	OPERATION
0	0	0	0	-	0	0	0	1	RECEIVE operation with negative Acknowledge (Master remains in Receiver mode)
0	0	0	0	-	-	1	0	0	STOP condition**
0	0	0	0	-	0	1	0	1	RECEIVE followed by STOP condition
0	0	0	0	-	1	0	0	1	RECEIVE operation (Master remains in Receiver mode)
0	0	0	0	-	1	1	0	1	forbidden sequence
0	0	0	0	1	0	0	1	1	Repeated START condition followed by RECEIVE operation with negative Acknowledge (Master remains in Receiver mode)
0	0	0	0	1	0	1	1	1	Repeated START condition followed by RECEIVE and STOP condition
0	0	0	0	1	1	0	1	1	Repeated START condition followed by RECEIVE (Master remains in Receiver mode)
0	0	0	0	0	-	0	1	1	Repeated START condition followed by SEND (Master remains in Transmitter mode)
0	0	0	0	0	-	1	1	1	Repeated START condition followed by SEND and STOP condition
1	0	0	-	-	-	-	-	-	I2CM module software reset

Table14.7 Control bits combinations permitted in Master Receiver mode

The status Register is consisted of six bits : the BUSY bit, the ERROR bit, the ADDR_ACK bit, the DATA_ACK bit, the ARB_LOST bit, and the IDLE bit.

I2CMSR (0xF5)

Address/Name	R/W	Bit 7	Bit 6	Bit 5	Bit 4	Bit 3	Bit 2	Bit 1	Bit 0
F5h I2CMSR	R/W	-	BUS_BUSY	IDLE	ARB_LOST	DATA_ACK	ADDR_ACK	ERROR	BUSY
Reset	0x20	0	0	1	0	0	0	0	0

IDLE : This bit indicates that I2C BUS controller is in the IDLE state .

BUSY : This bit indicates that I2C BUS controller receiving, or transmitting data on the bus, and other bits of Status register are no valid;

BUS_BUSY : This bit indicates that the Bus is Busy, and access is not possible. This bit is set / reset by START and STOP conditions;

ERROR : This bit indicates that due the last operation an error occurred: slave address wasn't acknowledged, transmitted data wasn't acknowledged, or I2C Bus controller lost the arbitration;

ADDR_ACK : This bit indicates that due the last operation slave address wasn't acknowledged;

ARB_LOST : This bit indicates that due the last operation I2C Bus controller lost the arbitration;

■ SLAVE ADDRESS REGISTER

The Slave address Register consists of eight bits : Seven address bits (A6-A0), and Receive/ not send bit R/S. The R/S bit determines if the next operation will be a Receive (high), or Send (low).

I2CMSA (0xF4)

Address/Name	R/W	Bit 7	Bit 6	Bit 5	Bit 4	Bit 3	Bit 2	Bit 1	Bit 0
F4h I2CMSA	R/W	A.6	A.5	A.4	A.3	A.2	A.1	A.0	R/S
Reset		0	0	0	0	0	0	0	0

■ I²C Buffer – RECEIVER AND TRANSMITTER REGISTERS

I2C module has two separated 1 byte buffer in receiver and transmitter and these are located in the same address (0xF6). The Transmitted Data Register consists of eight data bits which will be sent on the bus due the next Send, or Burst Send operation. The first send bit is D.7 (MSB).

I2CBUF (0xF6)

Address/Name	R/W	Bit 7	Bit 6	Bit 5	Bit 4	Bit 3	Bit 2	Bit 1	Bit 0
F6h I2CBUF	R/W	D.7	D.6	D.5	D.4	D.3	D.2	D.1	D.P
Reset		0	0	0	0	0	0	0	0

The Receiver Data Register consists of eight data bits which have been received on the bus due the last receive, or Burst Receive operation.

I2CBUF (0xF6)

Address/Name	R/W	Bit 7	Bit 6	Bit 5	Bit 4	Bit 3	Bit 2	Bit 1	Bit 0
F6h I2CBUF	R/W	D.7	D.6	D.5	D.4	D.3	D.2	D.1	D.P
Reset		0	0	0	0	0	0	0	0

14.2.4 I2C MASTER MODULE AVAILABLE SPEED MODES

Default transmission parameter/constant values are shown in sections below. SCL clock frequency can be changed by modification of timer period values as show in the table below.

■ I2C MASTER MODULE STANDARD MODE

Typical configuration values for Standard speed mode :

The following table gives an example parameters for standard I2C speed mode.

System clock	TIMER_PERIOD	Transmission speed
4 MHz	1 (01h)	100kb/s
6 MHz	2 (02h)	100kb/s
10 MHz	4 (04h)	100kb/s
16 MHz	7 (07h)	100kb/s
20 MHz	9 (09h)	100kb/s

Table14.8 I2C MASTER MODULE Timer period values for standard speed mode

■ I2C MASTER MODULE FAST MODE

Typical configuration values for Fast speed mode :

The following table gives example parameters for Fast I2C speed mode.

System clock	TIMER_PERIOD	Transmission speed
10 MHz	1 (01h)	250 Kb/s
16 MHz	1 (01h)	400 Kb/s
20 MHz	2 (02h)	333 Kb/s

Table14.8 I2C MASTER MODULE Timer period values for Fast speed mode

14.2.5 I2C MASTER MODULE AVAILABLE COMMAND SEQUENCES

■ **I2C MASTER MODULE SINGLE SEND**

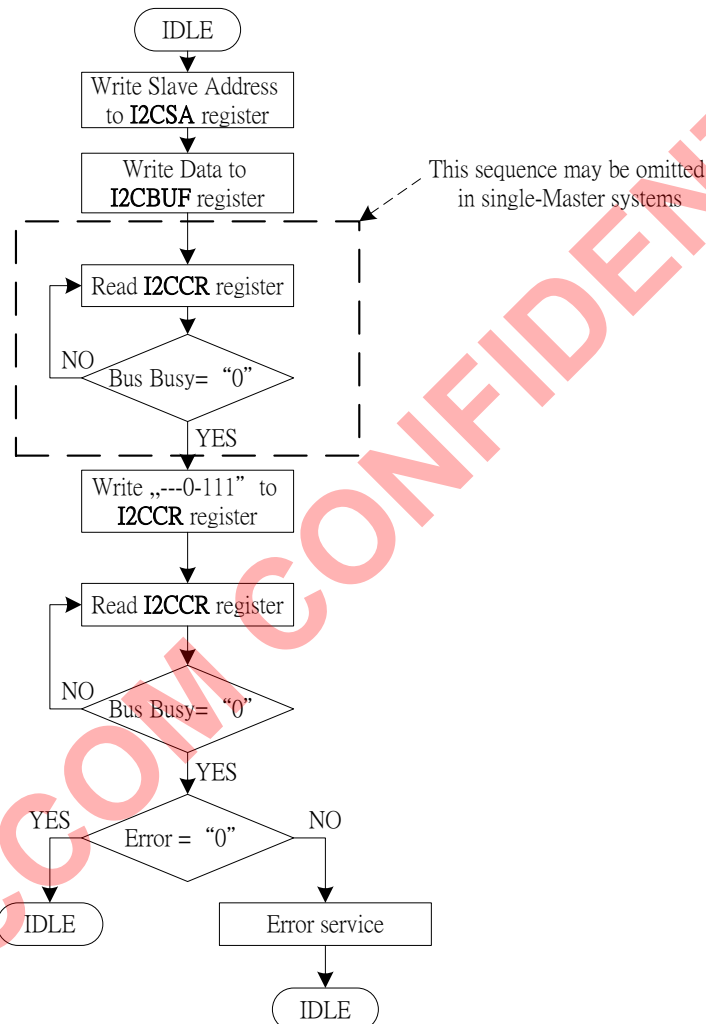

Figure14.4 I2C MASTER MODULE Single SEND flowchart

■ I2C MASTER MODULE SINGLE RECEIVE

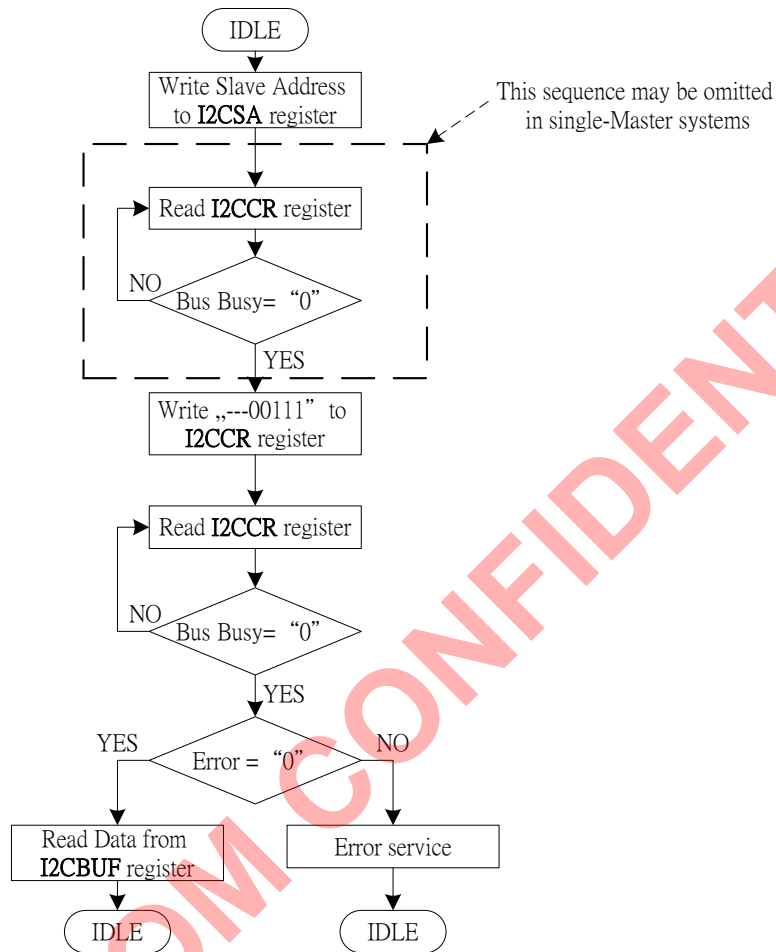

Figure14.5 Single RECEIVE flowchart

AMICCOM CONFIDENTIAL

■ I2C MASTER MODULE BURST SEND

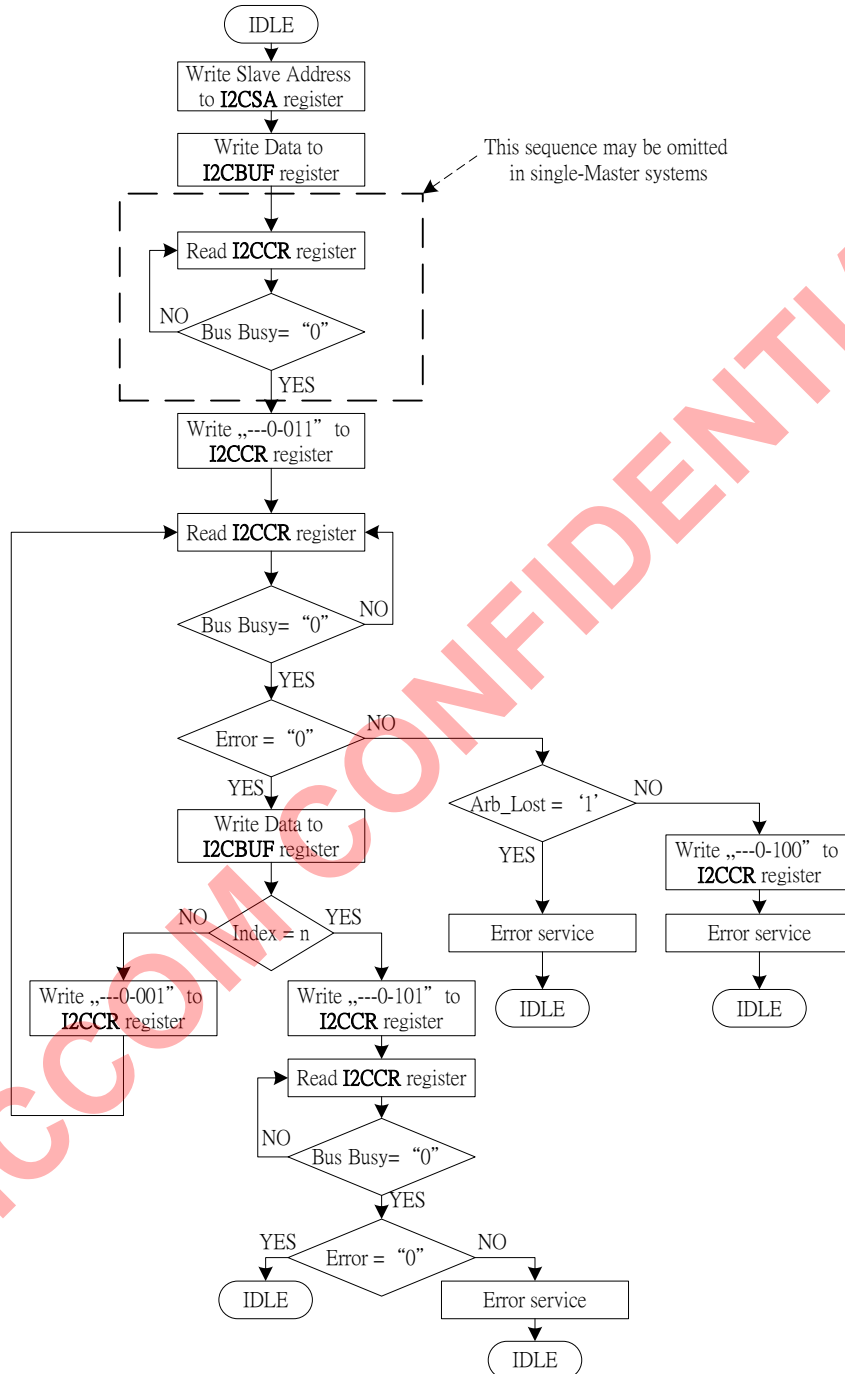

Figure14.6 I2C MASTER MODULE Sending n bytes flowchart

■ I2C MASTER MODULE BURST RECEIVE

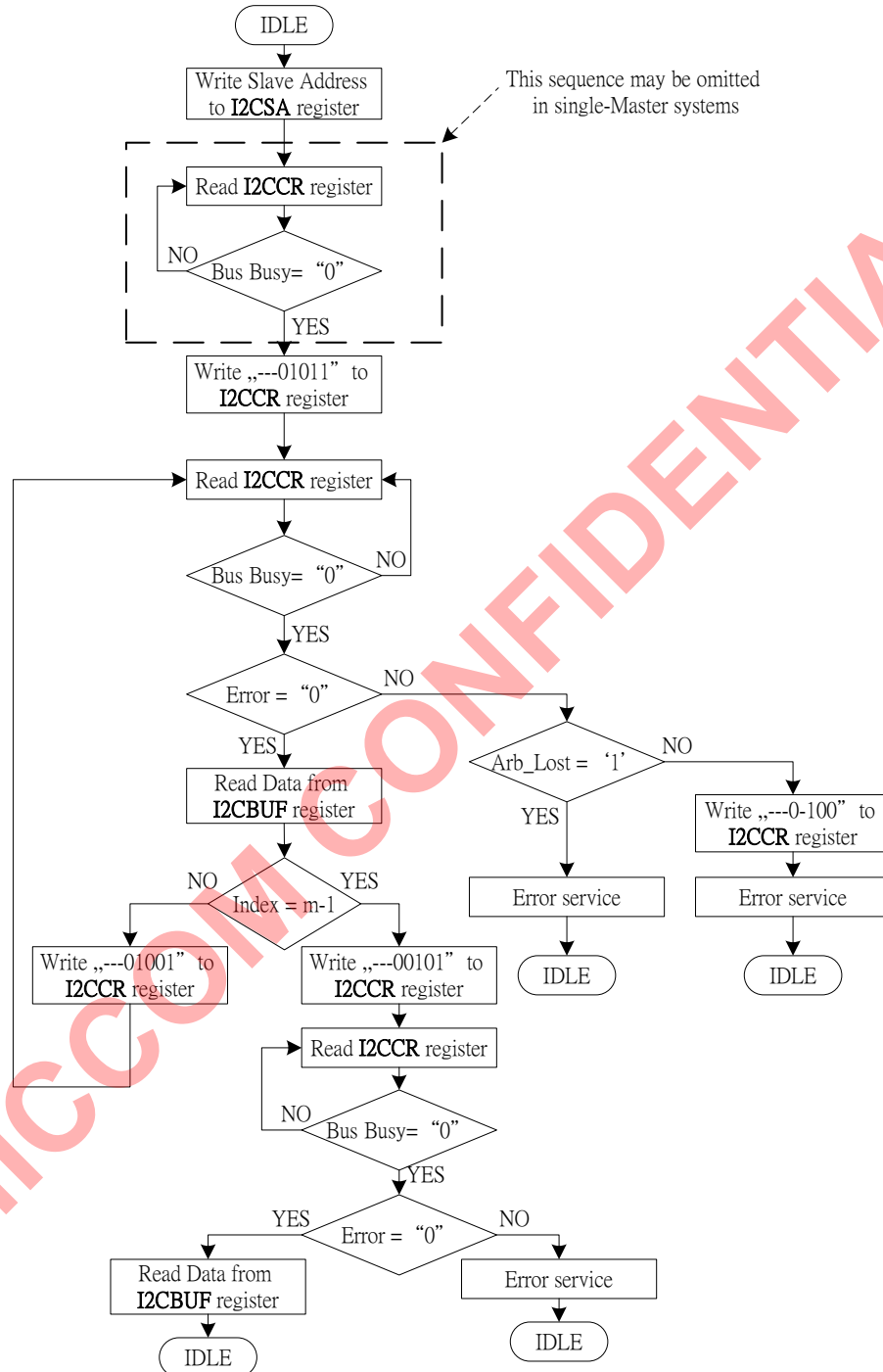

Figure14.7 I2C MASTER MODULE Receiving m bytes flowchart

■ I2C MASTER MODULE BURST RECEIVE AFTER BURST SEND

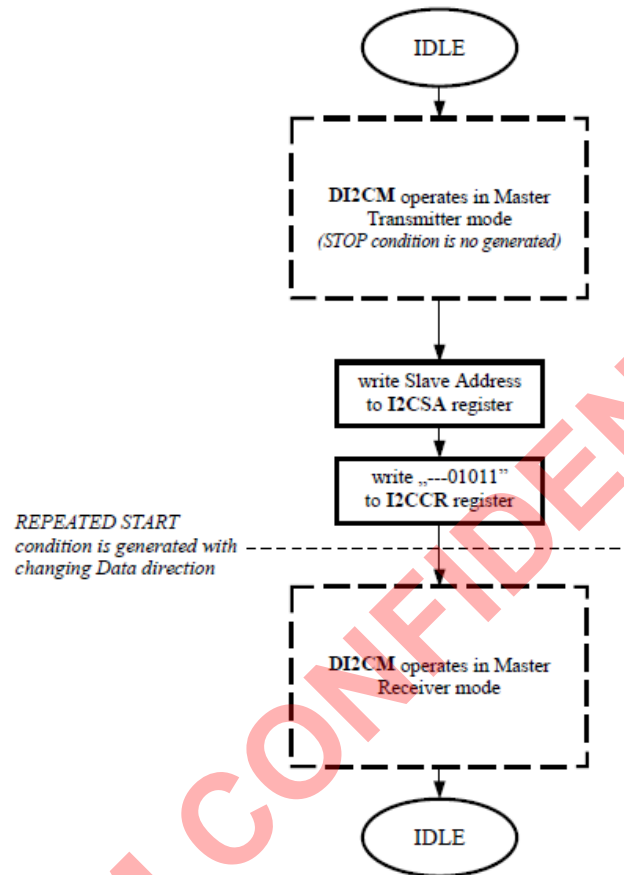

Figure14.8 I2C MASTER MODULE Sending n bytes then Repeated Start and Receiving m bytes flowchart

AMICCOM CONFIDENTIAL

■ I2C MASTER MODULE BURST SEND AFTER BURST RECEIVE

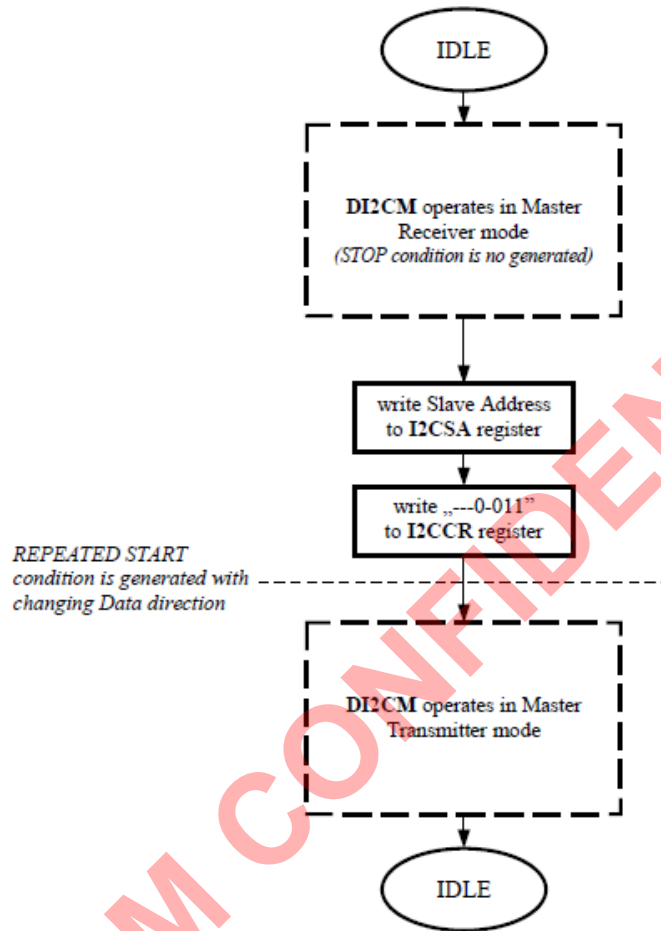

Figure14.9 I2C MASTER MODULE Receiving m bytes then Repeated Start and Sending n bytes flowchart

Figure14.10 I2C MASTER MODULE Single RECEIVE with 10-bit addressing flowchart

■ I2C MASTER MODULE ACK POLLING

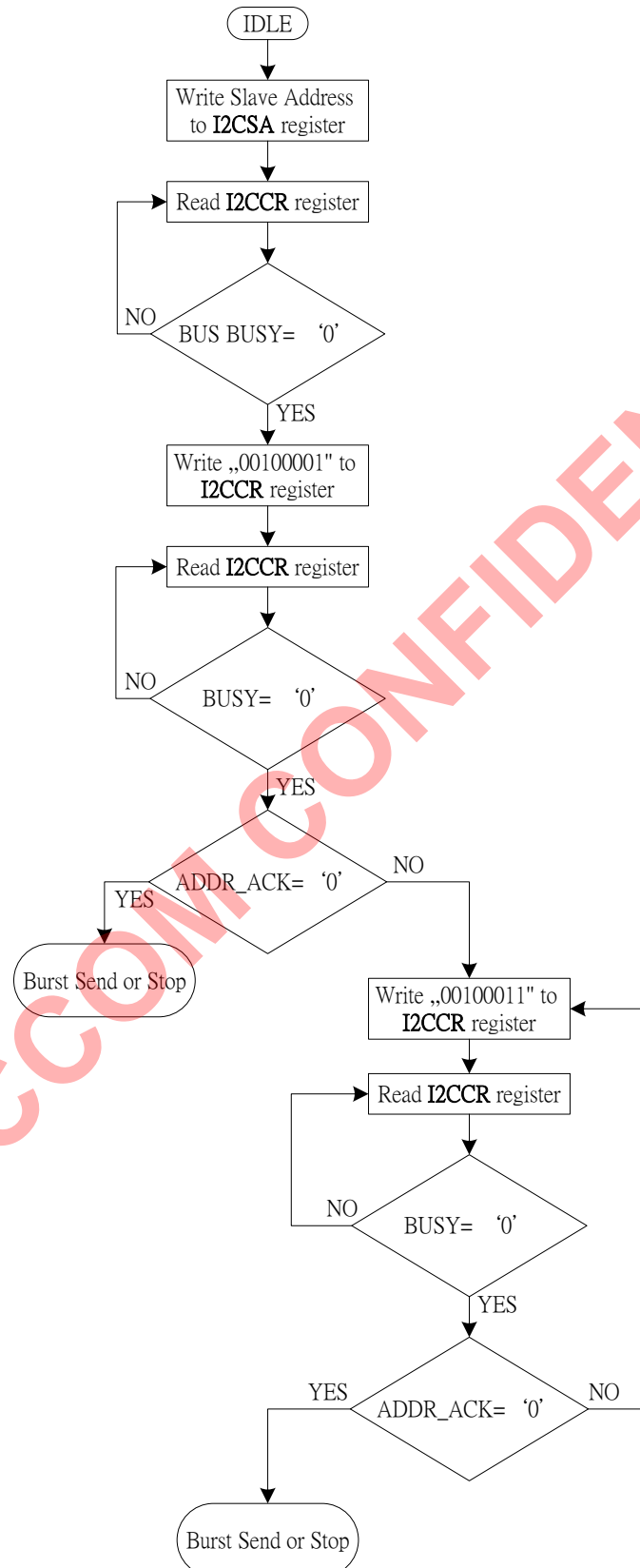

Figure14.11 I2C MASTER MODULE ACK Polling flowchart

14.3 I2C MASTER MODULE INTERRUPT GENERATION

I2C MASTER MODULE interrupt flag is automatically asserted when I2C transfer (send or receive a byte) is completed or transfer error has occurred. I2CMIF flag has to be cleared by software.

Interrupt flag	Function	Active level/edge	Flag resets	Vector	Natural priority
I2CMIF	Internal, I2C MASTER MODULE	-	Software	0x6B	14

Table14.11 I2C MASTER MODULE interrupt summary

I2C MASTER MODULE related interrupt bits have been summarized below. The IE (0xA8) contains global interrupt system disable (0) / enable (1) bit called EA.

EIE (0xE8)

Address/Name	R/W	Bit 7	Bit 6	Bit 5	Bit 4	Bit 3	Bit 2	Bit 1	Bit 0
E8h EIE Reset	R/W	EI2CS ESPI	EI2CM	EWDI	EKEYINT	ERFINT	EINT4	EINT3	EINT2
		0	0	0	0	0	0	0	0

EI2CM : Enable I2C MASTER MODULE interrupts

EIP (0xF8)

Address/Name	R/W	Bit 7	Bit 6	Bit 5	Bit 4	Bit 3	Bit 2	Bit 1	Bit 0
F8h EIP Reset	R/W	PI2CS PSPI	PI2CM	PWDI	PKEYINT	PRFINT	PINT4	PINT3	PINT2
		0	0	0	0	0	0	0	0

PI2CM : I2C MASTER MODULE priority level control (at 1-high-level)

EIF (0x91)

Address/Name	R/W	Bit 7	Bit 6	Bit 5	Bit 4	Bit 3	Bit 2	Bit 1	Bit 0
91h EIF Reset	R/W	I2CSF SPIF	I2CMF	-	KEYINTF	RFINTF	INT4F	INT3F	INT2F
		0	0	0	0	0	0	0	0

I2CMIF : I2C MASTER MODULE interrupt flag

It must be cleared by software writing logic '1'. Writing '0' does not change its content.

14.5 Slave mode I²C

The I²C module provides an interface between a microprocessor and I²C bus. It can work as a slave receiver or transmitter depending on working mode determined by microprocessor/microcontroller. The core incorporates all features required by I²C specification. The I²C module supports all the transmission modes: Standard and Fast.

14.5.1 I2C MODULE INTERNAL REGISTERS

There are five registers used to interface to the target device : The Own Address, Control, Status, Transmitted Data and Received Data registers.

Register	Address
Own address – I2CSOA	0xF1
Control – I2CSCR	0xF2
Transmitted data – I2CSBUF	0xF3

Table14.12 I2C MODULE Registers for writing

Register	Address
Own address – I2CSOA	0xF1
Control – I2CSSR	0xF2

Received data – I2CSBUF 0xF3

Table 14.13 I2C MODULE Registers for reading

■ I2CSOA – OWN ADDRESS REGISTER

The Own Address Register consists of seven address bits which identify I²C module core on I²C Bus. This register can be read and written at the address 0xF1.

I2CSOA (0xF1)

Address/Name	R/W	Bit 7	Bit 6	Bit 5	Bit 4	Bit 3	Bit 2	Bit 1	Bit 0
F1h I2CSOA	R/W	-	A.6	A.5	A.4	A.3	A.2	A.1	A0
Reset		0	0	0	0	0	0	0	0

■ I2CSCR – CONTROL AND STATUS REGISTERS

The Control Register consists of the bits : The RSTB and DA bit. The RSTB bit performs reset of whole I²C controller and behaves identically as external reset provided by RST pin. Using this bit software application can reinitialize I²C module when some problem is encountered on I²C bus. The DA bit enables ('1') and disable ('0') the I²C module device operation. DA is set immediately to '1' when MCU write DA=1. This register can be only written at address 0xF2. Reading this address puts status register on data bus – see below.

I2CSCR (0xF2)

Address/Name	R/W	Bit 7	Bit 6	Bit 5	Bit 4	Bit 3	Bit 2	Bit 1	Bit 0
F2h I2CSCR	R/W	RSTB	DA	-	-	RECFINCLR	SENDFINCLR	-	-
Reset		0	0	0	0	0	0	0	0

DA : Device Active – enable or disable the I²C module device operation;

RSTB : Reset of whole I²C controller by writing '1' to this bit. It behaves identically as RST pin

RECFINCLR : Writing '1' to this bit clears RECFIN bit from the I2C MODULE status register.

SENDFINCLR : Writing '1' to this bit clears SENDFIN bit from the I2C MODULE status register.

The Status Register consists of five bits: the DA, BUSACTIVE, RECFIN, SENDFIN bit, RREQ bit, TREQ bit. The receive finished RECFIN bit indicates that Master I2C controller has finished transmitting of data during single or burst receive operations. It also causes generation of interrupt on IRQ pin. The send finished SENDFIN bit indicates that Master I2C controller has finished receiving of data during single or burst send operations. It also causes generation of interrupt on IRQ pin. The Receive Request RREQ bit indicates that I²C module device has received data byte from I2C master. I²C module host device (usually MCU) should read one data byte from the Received Data register I2CSBUF. The Transmit Request TREQ bit indicates that I2C MODULE device is addressed as Slave Transmitter and I²C module host device (usually MCU) should write one data byte into the Transmitted Data register I2CSBUF. The BUSACTIVE '1' signalizes that any transmission (send, receive or own address detection) is in progress. BUSACTIVE is cleared ('0') automatically by I²C module in case when there is no any transmission. This is read only bit.

The DA bit should be polled (read) when MCU wrote DA=0. The DA bit is not immediately cleared when any I2C transmission (send, receive or own address detection) is in progress. When current transmission has completed then this bit is cleared to '0' and I²C module become inactive.

I2CSSR (0xF2)

Address/Name	R/W	Bit 7	Bit 6	Bit 5	Bit 4	Bit 3	Bit 2	Bit 1	Bit 0
F2h I2CSSR	R/W		DA	-	BUSACTIVE	RECFIN	SENDFIN	TREQ	RREQ
Reset		0	0	0	0	0	0	0	0

DA : Device Active – enable ('1') or disable ('0') the I2C MODULE device operation;

BUSACTIVE : Bus ACTIVE – '1' signalizes that any transmission: send, receive or own address detection is in progress;

RREQ : Indicates that I²C module device has received data byte from I²C master;

It is automatically cleared by read of I2CSBUF.

TREQ : Indicates that I²C module device is addressed as transmitter and requires data byte from host device;

It is automatically cleared by write data I2CSBUF.

RECFIN : Indicates that Master I2C controller has ended transmit operation. It means that no more RREQ will be set during this single or burst I²C module receive operation. It is cleared by writing '1' to the RECFINCLR bit in the I²C module control register.

SENDFIN : Indicates that Master I2C controller has ended receive operation. It means that no more TREQ will be set during this single or burst I²C module send operation. It is cleared by writing '1' to the SENDFINCLR bit in the I2C control register.

NOTE : All bits are active at HIGH level ('1').

■ I2CSBUF – RECEIVER AND TRANSMITTER REGISTERS

The Transmitter Data Register consists of eight Data bits which will be sent on the bus due the next Send operation. The first send bit is the D.7(MSB).

I2CSBUF (0xF3)

Address/Name	R/W	Bit 7	Bit 6	Bit 5	Bit 4	Bit 3	Bit 2	Bit 1	Bit 0
F3h I2CSBUF	R/W	D.7	D.6	D.5	D.4	D.3	D.2	D.1	D.0
Reset		0	0	0	0	0	0	0	0

The Receiver Data Register consists of eight data bits which have been received on the bus due the last Receive operation.

I2CSBUF (0xF3)

Address/Name	R/W	Bit 7	Bit 6	Bit 5	Bit 4	Bit 3	Bit 2	Bit 1	Bit 0
F3h I2CSBUF	R/W	D.7	D.6	D.5	D.4	D.3	D.2	D.1	D.0
Reset		0	0	0	0	0	0	0	0

14.7 AVAILABLE I2C MODULE TRANSMISSION MODES

This chapter describes all available transmission modes of the I²C module core. Default I2C own address for all presented waveforms is 0x39 ("0111001").

14.7.1 I²C module SINGLE RECEIVE

The figure below shows a set of sequences during Single data Receive by I2C MODULE. Single receive sequences :

- ✧ Start condition
- ✧ I²C module is addressed by I2C Master as receiver
- ✧ Address is acknowledged by I²C module
- ✧ Data is received by I²C module
- ✧ Data is acknowledged by I²C module
- ✧ Stop condition

14.7.2 I²C module SINGLE SEND

The figure below shows a set of sequences during Single data Send by I2C MODULE. Single send sequences :

- ✧ Start condition
- ✧ I²C module is addressed by I2C Master as transmitter
- ✧ Address is acknowledged by I²C module
- ✧ Data is transmitted by I²C module
- ✧ Data is not acknowledged by I2C Master
- ✧ Stop condition

14.7.3 I²C module BURST RECEIVE

The figure below shows a set of sequences during Burst data Receive by I²C module. Burst receive sequences :

- ✧ Start condition
- ✧ I²C module is addressed by I2C Master as receiver
- ✧ Address is acknowledged by I²C module
- ✧ (1)Data is received by I²C module
- ✧ (2)Data is acknowledged by I²C module
- ✧ STOP condition

Sequences (1) and (2) are repeated until Stop condition occurs.

14.7.4 I²C module BURST SEND

The figure below shows a set of sequences during Burst Data Send by I²C module. Burst send sequences :

- ◇ Start condition
- ◇ I²C module is addressed by I2C Master as transmitter
- ◇ Address is acknowledged by I²C module
- ◇ (1)Data is transmitted by I²C module
- ◇ (2)Data is acknowledged by I2C Master
- ◇ (3)Last data is not acknowledged by I2C Master
- ◇ Stop condition

Sequences (1) and (2) are repeated until last transmitted data is not acknowledged (3) by I2C Master.

14.7.5 AVAILABLE I²C module COMMAND SEQUENCES FLOWCHART

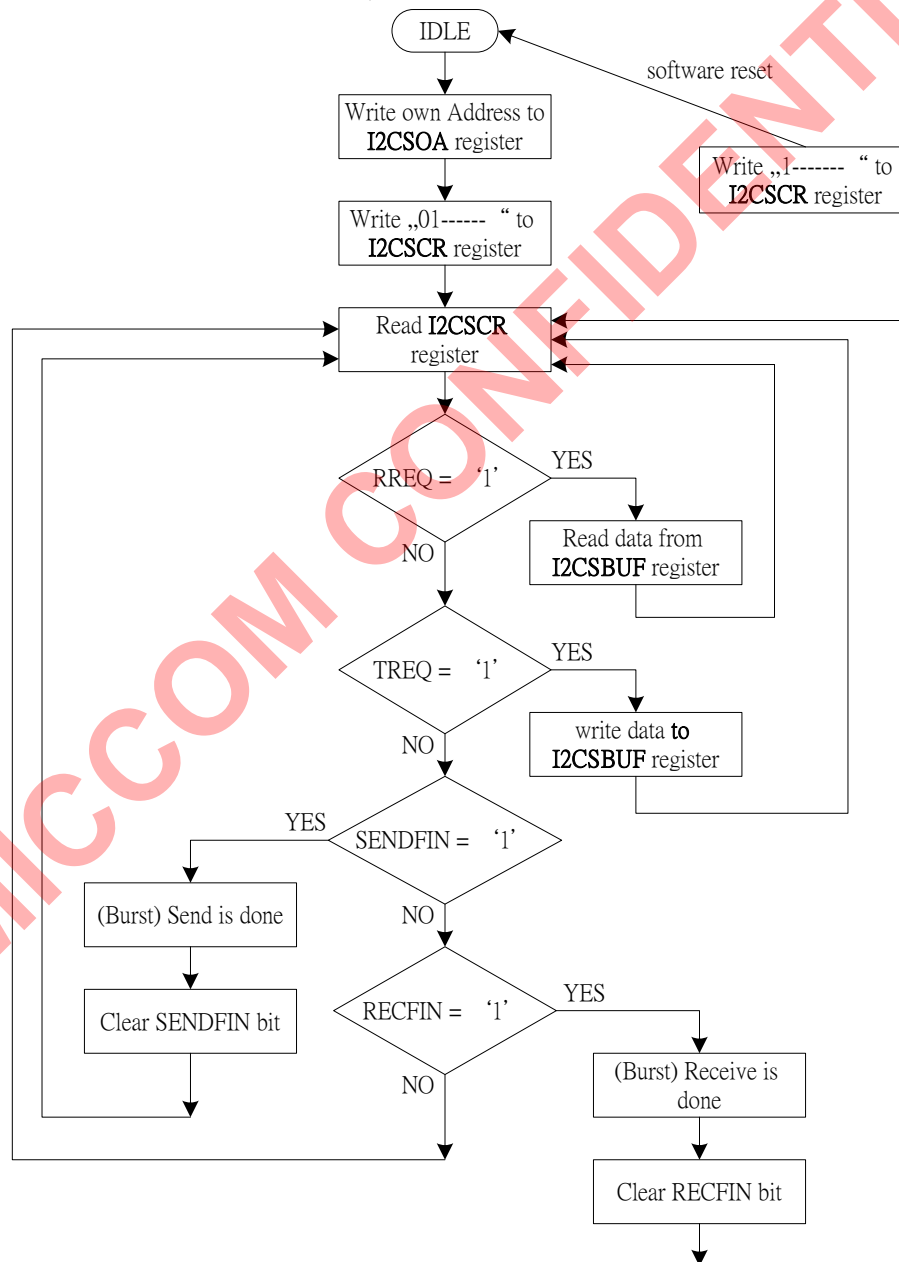

Figure14.20 Available I2C MODULE command sequences flowchart

14.8 I2C MODULE INTERRUPT GENERATION

I2C MODULE interrupt flag is automatically asserted when I2C transfer (send or receive a byte) is completed or transfer error has occurred. I2CSIF flag has to be cleared by software.

Interrupt flag	Function	Active level/edge	Flag resets	Vector	Natural priority
I2CSIF	Internal, DI2CS	-	Software	0x73	15

Table 14.16 I2C MODULE interrupt summary

I2C MODULE related interrupt bits have been summarized below. The IE (0xA8) contains global interrupt system disable (0) / enable (1) bit called EA.

EIE (0xE8)

Address/Name	R/W	Bit 7	Bit 6	Bit 5	Bit 4	Bit 3	Bit 2	Bit 1	Bit 0
E8h EIE	R/W	EI2CS ESPI	EI2CM	EWDI	EKEYINT	ERFINT	EINT4	EINT3	EINT2
Reset		0	0	0	0	0	0	0	0

EI2CS : Enable I2C MODULE interrupts

EIP (0xF8)

Address/Name	R/W	Bit 7	Bit 6	Bit 5	Bit 4	Bit 3	Bit 2	Bit 1	Bit 0
F8h EIP	R/W	PI2CS PSPI	PI2CM	PWDI	PKEYINT	PRFINT	PINT4	PINT3	PINT2
Reset		0	0	0	0	0	0	0	0

PI2CS : I2C MODULE priority level control (at 1-high-level)

EIF (0x91)

Address/Name	R/W	Bit 7	Bit 6	Bit 5	Bit 4	Bit 3	Bit 2	Bit 1	Bit 0
91h EIF	R/W	I2CSF SPIF	I2CMF	-	KEYINTF	RFINTF	INT4F	INT3F	INT2F
Reset		0	0	0	0	0	0	0	0

I2CSIF : I2C MODULE interrupt flag

Software should determine the source of interrupt by check both modules' interrupt related bits. It must be cleared by software writing 0x80. It cannot be set by software.

15. SPI interface

The SPI is a fully configurable SPI master/slave device, which allows user to configure polarity and phase of serial clock signal SCK.

The SPI allows the microcontroller to communicate with serial peripheral devices. It is also capable of inter-processor communications in a multi-master system. A serial clock line (SCK) synchronizes shifting and sampling of the information on the two independent serial data lines. SPI data are simultaneously transmitted and received.

The SPI is a technology independent design that can be implemented in a variety of process technologies.

The SPI system is flexible enough to interface directly with numerous standard product peripherals from several manufacturers. The system can be configured as a master or a slave device. Data rates as high as System clock divided by four (CLK/4). Clock control logic allows a selection of clock polarity and a choice of two fundamentally different clocking protocols to accommodate most available synchronous serial peripheral devices. When the SPI is configured as a master, software selects one of four different bit rates for the serial clock.

The SPI automatically drive selected by SSCR (Slave Select Control Register) slave select outputs (SS70 – SS00), and address SPI slave device to exchange serially shifted data.

Error-detection logic is included to support inter-processor communications. A write-collision detector indicates when an attempt is made to write data to the serial shift register while a transfer is in progress. A multiple-master mode-fault detector automatically disables SPI output drivers if more than one SPI devices simultaneously attempts to be become bus master.

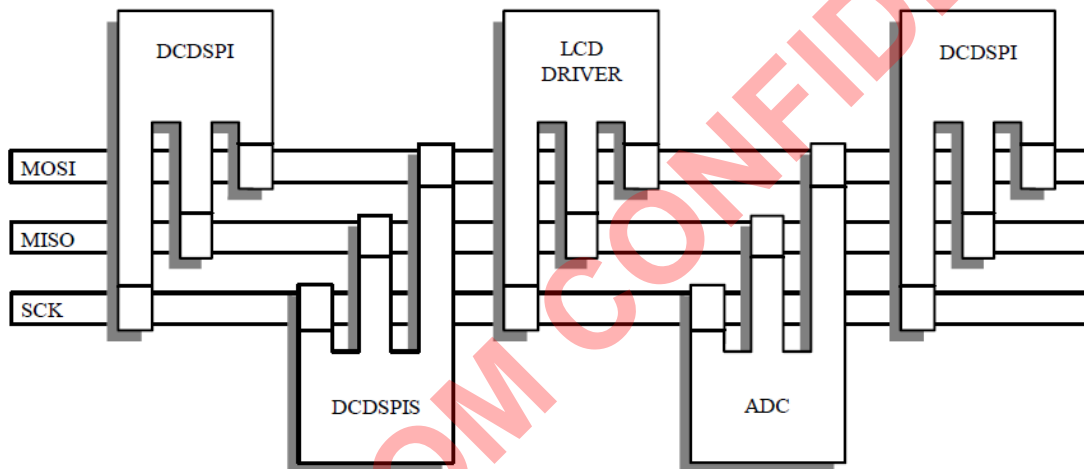

15.1 KEY FEATURES

All features listed below are included in the current version of SPI core.

- SPI Master
 - Full duplex synchronous serial data transfer
 - Master operation
 - Multi-master system supported
 - Up to 8 SPI slaves can be addressed
 - System error detection
 - Interrupt generation
 - Supports speeds up to 1/4 up to system clock
 - Bit rates generated 1/4, 1/8, 1/32, 1/64, 1/128, 1/512 of system clock
 - Four transfer formats supported
 - Simple interface allows easy connection to microcontrollers
- SPI Slave
 - Full duplex synchronous serial data transfer
 - Slave operation
 - System error detection
 - Interrupt generation
 - Supports speeds up to 1/4 of system clock
 - Simple interface allows easy connection to microcontrollers

- Four transfer formats supported
- Fully synthesizable, static synchronous design with no internal tri-states

15.2 SPI PINS DESCRIPTION

PIN	TYPE	ACTIVE	DESCRIPTION
Scki_Scko(P0.0)	INPUT / OUTPUT	-	SPI clock input / output
MISO(P0.1)	INPUT / OUTPUT	-	Master serial data input / Slave serial data output
SIMO(P0.2)	INPUT / OUTPUT	-	Slave serial data input / Master serial data output
SSO(P0.3)	OUTPUT	low	Slave select output

Table 15.1 SPI pins description

15.3 SPI HARDWARE DESCRIPTION

15.3.1 BLOCK DIAGRAM

When an SPI transfer occurs, an 8-bit character is shifted out on data pin while a different 8-bit character is simultaneously shifted in a second data pin. Another way to view this transfer is that an 8-bit shift register in the master and another 8-bit shift register in the slave are connected as a circular 16-bit shift register. When a transfer occurs, this distributed shift register is shifted eight bit positions; thus, the characters in the master and slave are effectively exchanged.

The central element in the SPI system is the block containing the shift register and the read data buffer. The system is single buffered in the transmit direction and double buffered in the receive direction. This fact means new data for transmission cannot be written to the shifter until the previous transaction is complete; however, received data is transferred into a parallel read data buffer so the shifter is free to accept a second serial character. As long as the first character is read out of the read data buffer before the next serial character is ready to be transferred, no overrun condition will occur.

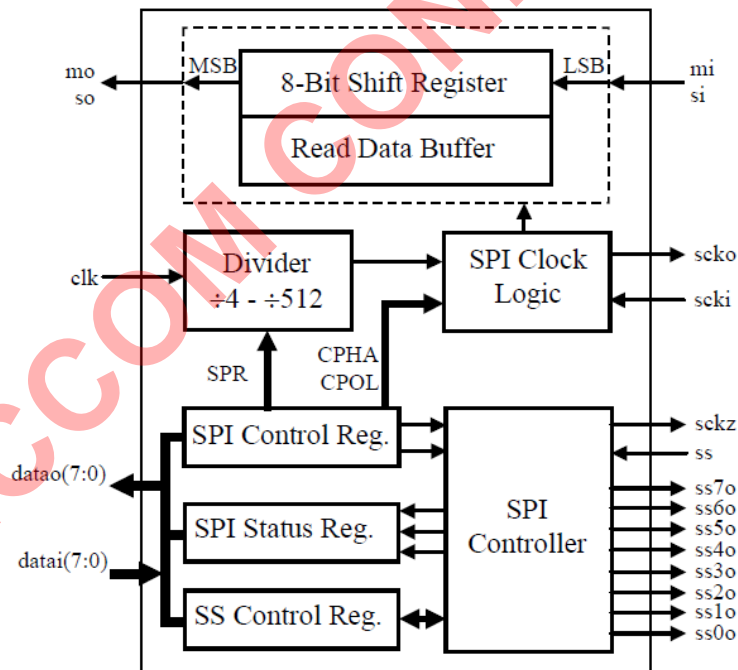

Figure 15.2 SPI Block Diagram

The eight pins are associated with the SPI: the SS, clock pins SCKI, SCKO and SCKEN, master pins MI and MO and slave pins SOEN, SI and SO.

The SS input pin in a master mode is used to detect mode-fault errors. A low on this pin indicates that some other device in a multi-master system has become a master and trying to select the SPI MODULE as a slave. The SS input pin in a slave mode is used to enable transfer.

The SCKI pin is used when the SPI is configured as a slave. The input clock from a master synchronizes data transfer between a master and the slave devices. The slave device ignore the SCKI signal unless the SS (slave select) pin is active low.

The SCKO and SCKEN pins are used as the SPI clock signal reference in a master mode. When the master initiates a transfer eight clock cycles is automatically generated on the SCKO pin.

When the SPI is configured as a slave the SI pin is the slave input data line, and the SO is the slave output data line.

When the SPI is configured as a master, the MI pin is the master input data line, and the MO is the master output data line.

15.3.2 INTERNAL REGISTERS

● SPI Control Register

The control register may be read or written at any time, is used to configure the SPI System.

SPCR (0xEC)

Address/Name	R/W	Bit 7	Bit 6	Bit 5	Bit 4	Bit 3	Bit 2	Bit 1	Bit 0
ECh EIE	R/W	SPIE	SPE	SPR2	MSTR	CPOL	CPHA	SPR1	SPR0
Reset		0	0	0	0	0	1	0	0

SPIE : SPI interrupt enable

= 0, interrupts are disabled, polling mode is used

= 1, interrupts are enabled

SPE : SPI system enable

= 0, system is off

= 1, system is on

MSTR : Master/Slave mode select

= 0, slave

= 1, master

CPOL : Clock polarity select

= 0, high level; SCK idle low

= 1, low level; SCK idle high

CPHA : Clock phase.. Select one of two different transfer formats

SPR[2:0] : SPI clock rate select bits. See the table below

SPR2	SPR1	SPR0	System clock divided by
0	0	0	4
0	0	1	8
0	1	0	16
0	1	1	32
1	0	0	64
1	0	1	128
1	1	0	256
1	1	1	512

● Slave Select Control Register

The control register may be read or written at any time. It is used to configure which slave select output should be driven while SPI master transfer. Contents of SSCR register is automatically assigned on SS70-SS00 pins when SPI master transmission starts.

SSCR (0xEF)

Address/Name	R/W	Bit 7	Bit 6	Bit 5	Bit 4	Bit 3	Bit 2	Bit 1	Bit 0
EFh SSCR	R/W	SS7	SS6	SS5	SS4	SS3	SS2	SS1	SS0
Reset		1	1	1	1	1	1	1	1

SS7 – SS0

= 0, Pin SSxO assigned while Master Transfer

= 1, Pin SSxO is forced to logic 1

● SPI Status Register

SPSR (0xED)

Address/Name	R/W	Bit 7	Bit 6	Bit 5	Bit 4	Bit 3	Bit 2	Bit 1	Bit 0
EDh	R/W	SPIF	WCOL	-	MODF	-	-	-	SSCEN

EIE									
Reset		0	0	0	0	0	1	0	0

SPIF : SPI interrupt request. The flag is automatically set to one at the end of an SPI transfer.

WCOL : Write collision error status flag. The flag is automatically set if the SPDR is written while a transfer is in process.

MODF : SPI mode-fault error status flag

This flag is set if SS pin goes to active low while the SPI is configured as a master (MSTR = 1)

SSCEN :

= 1, auto SS assertions enabled

= 0, auto SS assertions disabled – SSO always shows contents of SSCR

SPI status register (SPSR) contains flags indicating the completion of transfer or occurrence of system errors. All flags are set automatically when the corresponding event occur and cleared by software sequence. SPIF and WCOL are automatically cleared by reading SPSR followed by an access of the SPDR. MODF flag is cleared by reading SPSR with MODF set followed by a write to SPCR.

The SSCSEN bit is a enable bit of automatic Slave Select Outputs assertion. When SSCEN is set ('1') then during master transmission the SSXO lines are automatically loaded with contents of SSCR register before each byte transfer, and deasserted when byte is transferred. When SSCEN bit is cleared the SSXO lines always shows contents of the SSCR register, regardless of the transmission is in progress or SPI MODULE is in IDLE state.

- Receiver and Transmitter Registers

The Transmitted Data Register consists of eight data bits, which will be sending on the bus due the next Send operation.

The first send bit is the D.7 (MSB).

SPDR (0xEE)

Address/Name	R/W	Bit 7	Bit 6	Bit 5	Bit 4	Bit 3	Bit 2	Bit 1	Bit 0
EEd SPDR	R/W	D.7	D.6	D.5	D.4	D.3	D.2	D.1	D.0
Reset		0	0	0	0	0	1	0	0

The Received Data Register consists of eight data bits, which were received on the bus due the last Receive operation.

SPDR (0xEE)

Address/Name	R/W	Bit 7	Bit 6	Bit 5	Bit 4	Bit 3	Bit 2	Bit 1	Bit 0
EEd SPDR	R/W	D.7	D.6	D.5	D.4	D.3	D.2	D.1	D.0
Reset		0	0	0	0	0	1	0	0

15.4 MASTER OPERATIONS

When the SPI MODULE core is configured as a SPI master, the transfer is initiated by write to the SPDR register. When the new byte is written to the SPDR register, SPI MODULE begins transfer on the nearest BAUD timer overflow. The serial clock SCK is generated by the SPI MODULE. In master mode the SPI MODULE activates the SCKEN to enable the SCK output driver.

The SPI MODULE in master mode can select one of the eight SPI slave devices, through the SSxO lines. The SSxO lines – Slave Select output lines are loaded with contents of the SSCR register (0x03). The SSCEN bit from the SPSR register select between automatic SSxO lines control and software control. When set the automatic Slave Select outputs assertion is enabled. With SSCEN bit set in master mode the SSXO lines are automatically loaded with contents of SSCR register before each byte transfer, and deasserted when byte is transferred. When SSCEN bit is cleared the SSXO lines are controlled by the software, and always shows contents of the SSCR register, regardless of the transmission is in progress or the SPI MODULE is in IDLE state.

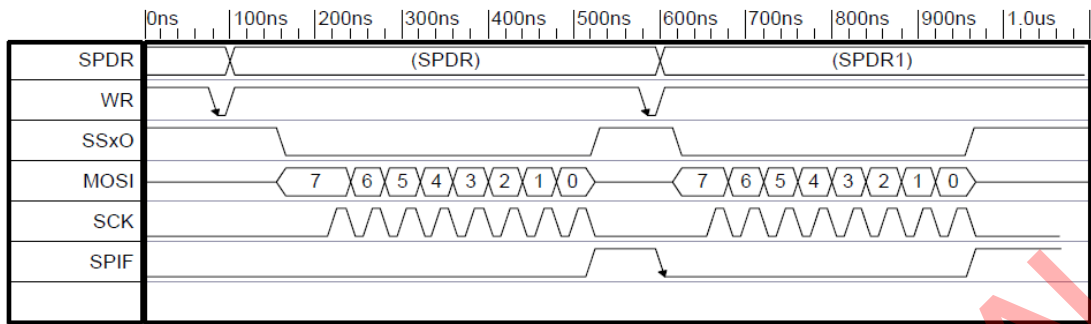

Figure15.3 Automatic slave select lines assertion

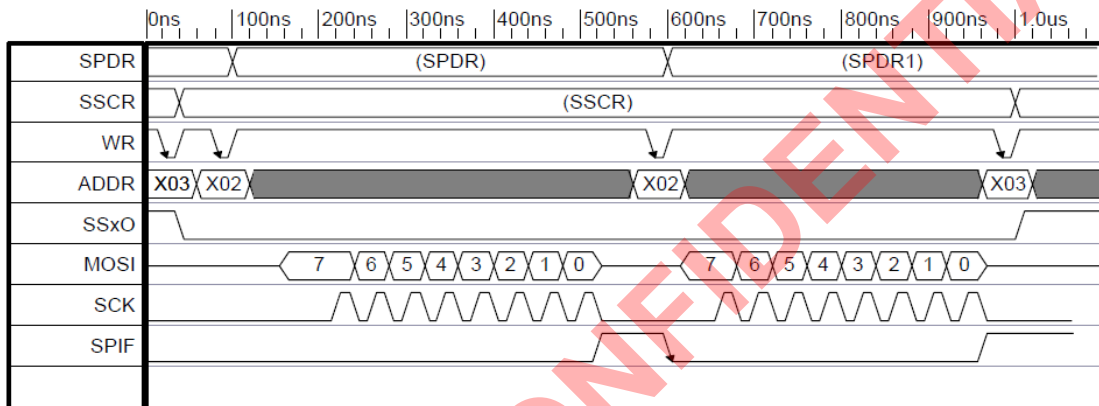

Figure15.4 Software controlled SSxO lines

15.4.1 MASTER MODE ERRORS

In master mode two system errors can be detected by the SPI MODULE. The first type of error arises in multiple-master system when more than one SPI device simultaneously tries to be a master. This error is called a Mode Fault. The second error type, a Write Collision, indicates that MCU tried to write the SPDR register while transfer was in progress.

◆ MODE FAULT ERROR

Mode fault error occurs when the SPI MODULE is configured as a master and some other SPI master device will select this device as if it were a slave. If a Mode Fault Error occur :

- ✧ The MSTR bit is forced to zero to reconfigure the SPI MODULE as a slave.
- ✧ The SPE bit is forced to zero to disable the SPI MODULE system
- ✧ The MODF status flag is set and an interrupt request is generated

The MODF flag is cleared by reading SPSR with MODF set followed by a write to SPCR

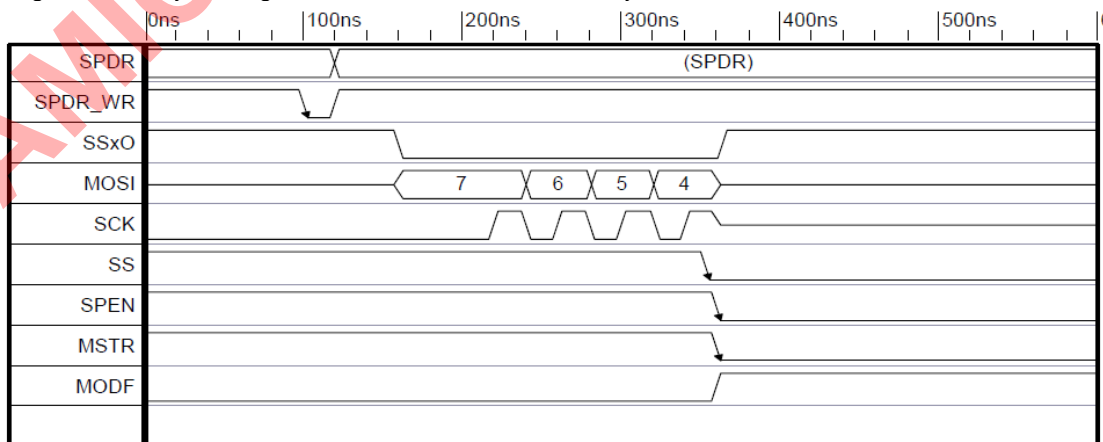

Figure15.5 Mode Fault Error generation

◆ WRITE-COLLISION ERROR

A write collision occurs if the SPI MODULE data register is written while a transfer is in progress. The transfer continues undisturbed, and the write data that caused the error is not written to the shifter. The Write Collision is indicated by the WCOL flag in SPSR (3) register.

The WCOL flag is set automatically by hardware, when the WCOL error condition occurs. To clear the WCOL bit, user should execute the following sequence:

- ✧ Read contents of the SPSR register
- ✧ Perform access to the SPDR register (read or write)

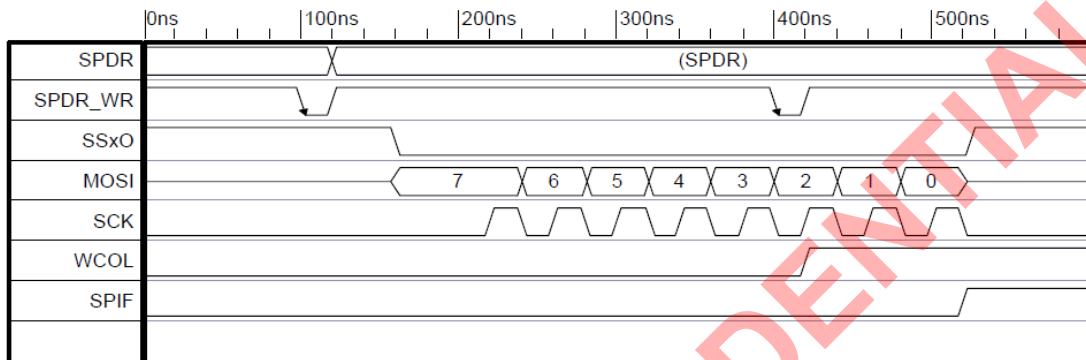

Figure15.6 Write Collision Error in SPI Master mode

15.5 SLAVE OPERATIONS

When configured as SPI Slave the SPI MODULE transfer is initiated by external SPI master module by assertion of the SPI MODULE Slave Select input, and generation of the SCK serial clock.

Before transfer starts, the SPI master has to assert the Slave Select line to determine which SPI slave will be used to exchange data. The SS is asserted (cleared = 0), the clock signal connected to the SXCK line will cause the SPI MODULE slave to shift into receiver shift register contents of the MOSI line, and drives the MISO line with contents of the Transmitter Shift register. When all eight bits are shifted in/out the SPI MODULE generates the Interrupt request by setting the IRQ output.

In SPI MODULE slave mode only one transfer error is possible – Write Collision Error.

15.5.1 SLAVE MODE ERRORS

In slave mode, only the Write Collision Error can be detected by the SPI MODULE.

The Write Collision Error occurs when the SPDR register write is performed while the SPI MODULE transfer is in progress.

In SLAVE mode when the CPHA is cleared, the write collision error may occur as long as the SS Slave Select line is driven low, even if all bits are already transferred. This is because there is not clearly specified the transfer beginning, and SS driven low after full byte transfer may indicate beginning of the next byte transfer.

◆ WRITE-COLLISION ERROR

A write collision occurs if the SPI MODULE data register is written while a transfer is in progress. The transfer continues undisturbed, and the write data that caused the error is not written to the shifter. The Write Collision is indicated by the WCOL flag in SPSR (3) register.

The WCOL flag is set automatically by hardware, when the WCOL error condition occurs. To clear the WCOL bit, user should execute the following sequence:

- ✧ Read contents of the SPSR register
- ✧ Perform access to the SPDR register (read or write)

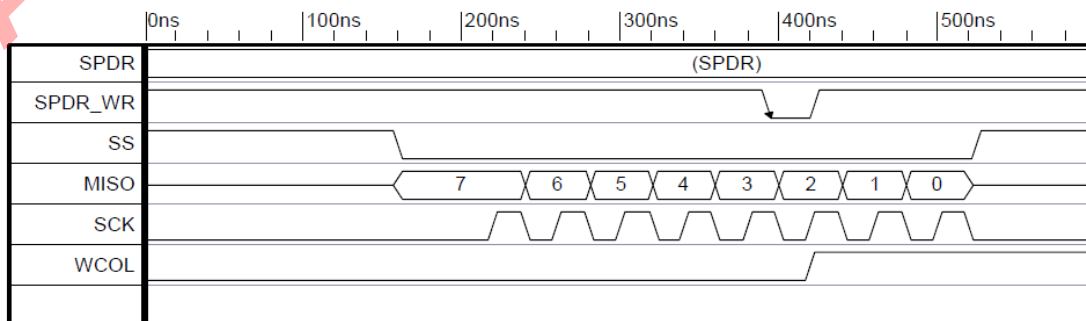

Figure15.7 Write Collision Error – SPI Slave mode – SPDR write during transfer

Figure below shows the WCOL generation, in case that the CPHA is cleared. As it is shown the WCOL generation is caused by any SPDR register write with SS line cleared. It is done even if the SPI master didn't generate the serial clock SCK. This is because there is not clearly specified the transfer beginning, and SS driven low after full byte transfer may indicate beginning of the next byte transfer.

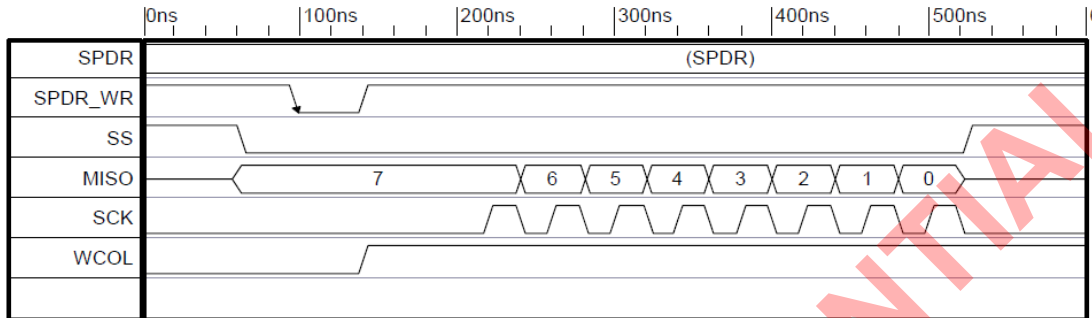

Figure 15.8 WCOL Error-SPI Slave mode-SPDR write when CPHA = 0 and SS = 0

15.6 CLOCK CONTROL LOGIC

15.6.1 SPI CLOCK PHASE AND POLARITY CONTROLS

Software can select any of four combinations of serial clock (SCK) phase and polarity using two bits in the SPI control register (SPCR). The clock polarity is specified by the CPOL control bit, which selects an active high or active low clock and has no significant effect on the transfer format. The clock phase (CPHA) control bit selects one of two fundamentally different transfer formats. The clock phase and polarity should be identical for the master SPI device and the communicating slave device. In some cases, the phase and polarity are changed between transfers to allow a master device to communicate with peripheral slaves having different requirements. The flexibility of the SPI system on the SPI MODULE allows direct interface to almost any existing synchronous serial peripheral.

15.6.2 SPI MODULE TRANSFER FORMATS

During an SPI transfer, data is simultaneously transmitted (shifted out serially) and received (shifted in serially). A serial clock line synchronizes shifting and sampling of the information on the two serial data lines. A slave select line allows individual selection of a slave SPI device; slave devices that are not selected do not interfere with SPI bus activities. On a master SPI device, the slave select line can optionally be used to indicate a multiple-master bus contention.

15.6.3 CPHA EQUALS ZERO TRANSFER FORMAT

Figure below shows a timing diagram of an SPI transfer where CPHA is 0. Two waveforms are shown for SCK: one for CPOL equals 0 and another for CPOL equals 1. The diagram may be interpreted as a master or slave timing diagram since the SCK, master in/slave out (MISO), and master out/slave in (MOSI) pins are directly connected between the master and the slave. The MISO signal is the output from the slave, and the MOSI signal is the output from the master. The SS line is the slave select input to the slave; the SS pin of the master is not shown but is assumed to be inactive. The SS pin of the master must be high. This timing diagram functionally depicts how a transfer takes place; it should not be used as a replacement for data-sheet parametric information.

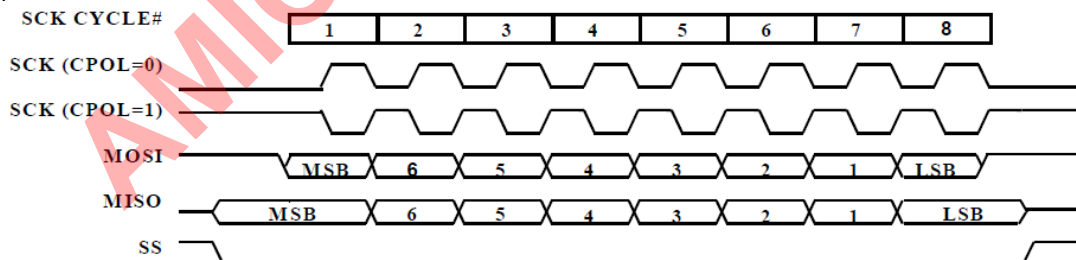

Figure 15.9 CPHA Equals Zero SPI Transfer Format

When CPHA = 0, the SS line must be deasserted and reasserted between each successive serial byte. Also, if the slave writes data to the SPI data register (SPDR) while SS is active low, a write-collision error results. When CPHA = 1, the SS line may remain active low between successive transfers (can be tied low at all times). This format is sometimes preferred in systems having a single fixed master and a single slave driving the MISO data line.

15.6.4 CPHA EQUALS ONE TRANSFER FORMAT

Figure below is a timing diagram of an SPI transfer where CPHA = 1. Two waveforms are shown for SCK: one for CPOL = 0 and another for CPOL = 1. The diagram may be interpreted as a master or slave timing diagram since the SCK, MISO, and

MOSI pins are directly connected between the master and the slave. The MISO signal is the output from the slave, and the MOSI signal is the output from the master. The SS line is the slave select input to the slave; the SS pin of the master is not shown but is assumed to be inactive. The SS pin of the master must be high or must be reconfigured as a general-purpose output not affecting the SPI.

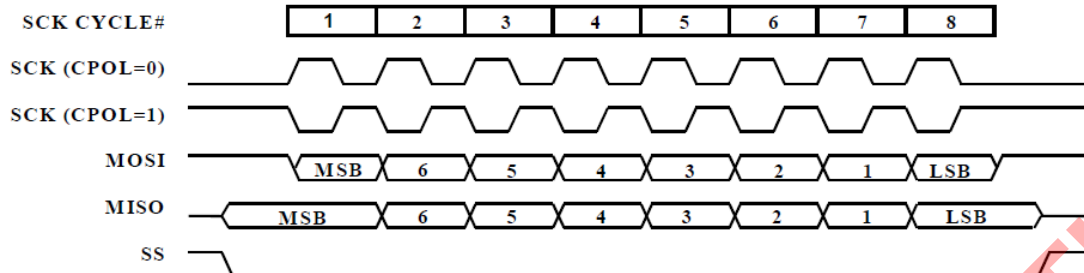

Figure15.10 CPHA Equals One SPI Transfer Format

15.7 SPI DATA TRANSFER

15.7.1 TRANSFER BEGINNING PERIOD (INITIATION DELAY)

All SPI transfers are started and controlled by a master SPI device. As a slave, the SPI MODULE considers a transfer to begin with the first SCK edge or the falling edge of SS, depending on the CPHA format selected. When CPHA = 0, the falling edge of SS indicates the beginning of a transfer. When CPHA = 1, the first edge on the SCK indicates the start of the transfer. In either CPHA format, a transfer can be aborted by taking the SS line high, which causes the SPI slave logic and bit counters to be reset. The SCK rate selected has no effect on slave operations since the clock from the master is controlling transfers.

When the SPI is configured as a master, transfers are started by a software write to the SPDR.

15.7.2 TRANSFER ENDING PERIOD

An SPI transfer is technically complete when the SPIF flag is set, but, depending on the configuration of the SPI system, there may be additional tasks. Because the SPI bit rate does not affect timing of the ending period, only the fastest rate is considered in discussions of the ending period. When the SPI is configured as a master, SPIF is set at the end of the eighth SCK cycle. When CPHA equals 1, SCK is inactive for the last half of the eighth SCK cycle.

When the SPI is operating as a slave, the ending period is different because the SCK line can be asynchronous to the MCU clocks of the slave and because the slave does not have access to as much information about SCK cycles as the master. For example, when CPHA = 1, where the last SCK edge occurs in the middle of the eighth SCK cycle, the slave has no way of knowing when the end of the last SCK cycle is. For these reasons, the slave considers the transfer complete after the last bit of serial data has been sampled, which corresponds to the middle of the eighth SCK cycle.

The SPIF flag is set at the end of a transfer, but the slave is not permitted to write new data to the SPDR while the SS line is still low.

15.8 TIMING DIAGRAMS

15.8.1 MASTER TRANSMISSION

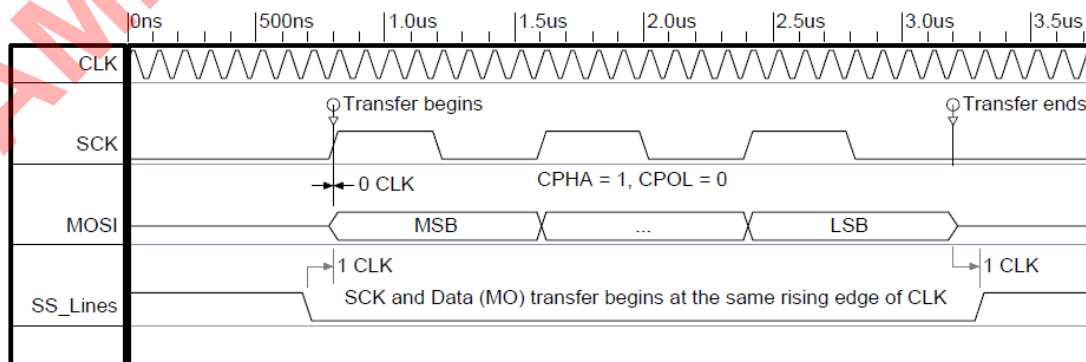

Figure15.11 Master mode timing diagram

15.8.2 SLAVE TRANSMISSION

At a beginning of transfer in Slave mode, the data on serial output (MISO) appears on first rising edge after falling edge on Slave Select (SS) line. Next bits of serial data are driving into MISO line on first rising edge of CLK after SKC active edge (in this case rising edge of SCK).

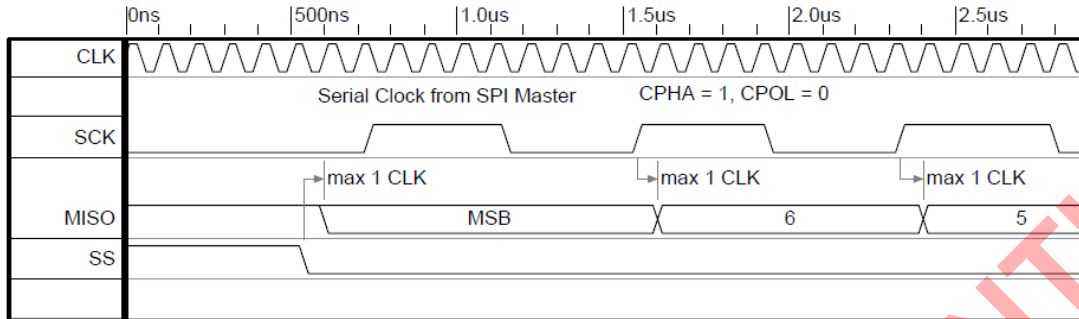

Figure 15.12 Slave mode timing diagram

15.9 SPI MODULE INTERRUPT GENERATION

When interrupt is enabled (SPIE bit in SPCR=1), SPI interrupt flag is automatically asserted when SPI transfer is completed or transfer error has occurred. SPIIF flag has to be cleared by software.

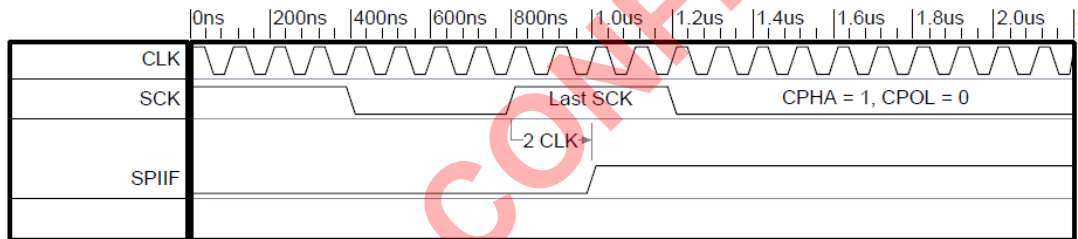

Figure 15.13 Interrupt generation

Interrupt flag	Function	Active level/edge	Flag resets	Vector	Natural priority
SPIIF	Internal, SPI	-	Software	0x73	15

Table 15.2 SPI interrupt summary

SPI related interrupt bits have been summarized below. The IE (0xA8) contains global interrupt system disable (0) / enable (1) bit called EA.

EIE (0xE8)

Address/Name	R/W	Bit 7	Bit 6	Bit 5	Bit 4	Bit 3	Bit 2	Bit 1	Bit 0
E8h EIE	R/W	EI2CS ESPI	EI2CM	EWDI	EKEYINT	ERFINT	EINT4	EINT3	EINT2
Reset		0	0	0	0	0	0	0	0

ESPI : Enable SPI Interrupts

EIP (0xF8)

Address/Name	R/W	Bit 7	Bit 6	Bit 5	Bit 4	Bit 3	Bit 2	Bit 1	Bit 0
F8h EIP	R/W	PI2CS PSPI	PI2CM	PWDI	PKEYINT	PRFINT	PINT4	PINT3	PINT2
Reset		0	0	0	0	0	0	0	0

PSPI : SPI priority level control (at 1-high-level)

EIF (0x91)

Address/Name	R/W	Bit 7	Bit 6	Bit 5	Bit 4	Bit 3	Bit 2	Bit 1	Bit 0
91h EIF	R/W	I2CSF SPIF	I2CMF	-	KEYINTF	RFINTF	INT4F	INT3F	INT2F
Reset		0	0	0	0	0	0	0	0

SPIIF : SPI interrupt flag

It must be cleared by software

AMICCOM CONFIDENTIAL

16. PWM

A8105 has two channels Pulse width modulator (PWM) output. Every channel PWM has an 8-bit counter with comparator, a control register (PWMxCON) and two setting registers (PWMxH and PWMxL). User can select clock source by setting PWMxCON. Enable PWM output and function by setting PWMxEN = 1; otherwise disable PWM output and function by setting PWMxEN = 0. When user set PWMxEN=0, it output LOW single and reload the PWMxL to itself. When the counter is enabled and matches the content of PWMxH, its output is asserted HIGH; when the counter is overflow, its output is asserted LOW and reload PWMxL to itself. The pulse frequency and the duty cycle for 8-bit PWM is given by the below equation

$$\text{Pulse frequency} = \text{System clock} / 2^{\text{pwxclock}+1} / (255-\text{PWMxL})$$

$$\text{Duty cycle} = (255-\text{PWMxH}) / 255-\text{PWMxL}$$

Noted: PWMxH must be larger then PWMxL. Otherwise, PWM output always is LOW.

16.1 PWM FUNCTIONALITY

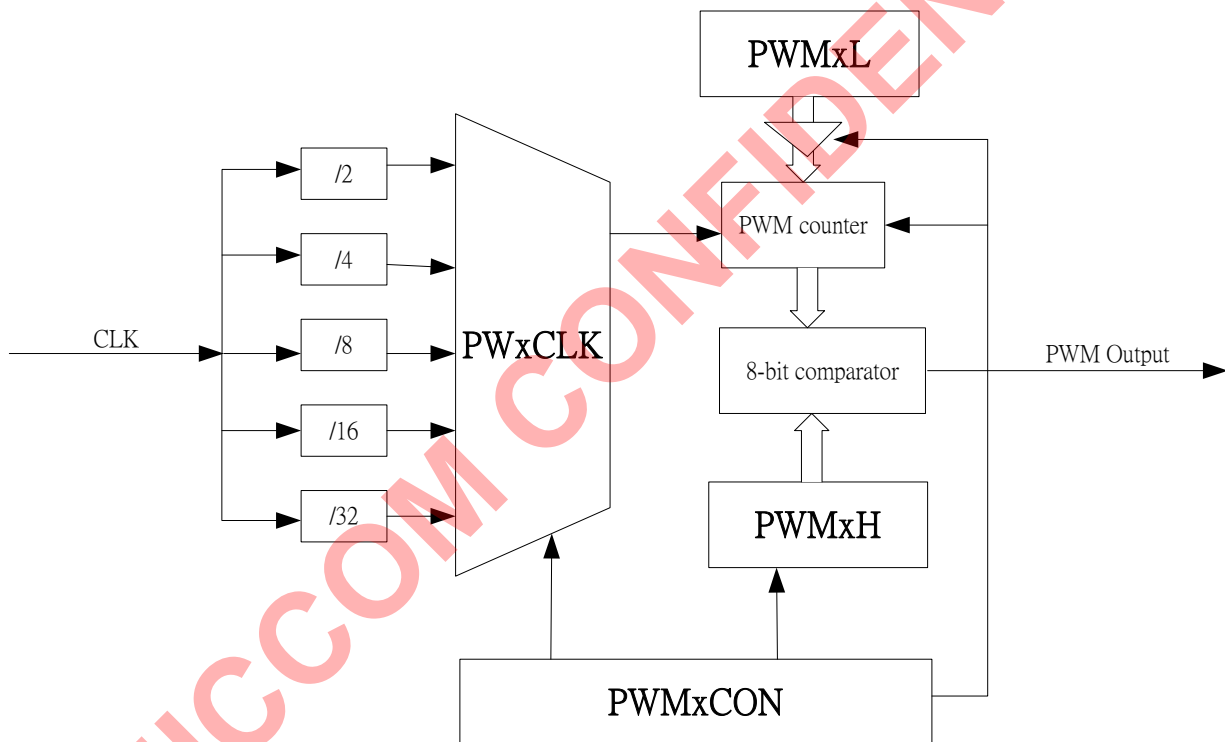

Figure 16.1 PWM Block Diagram

The PWM pins functionality is described in the following table. All pins are one directional.

PIN	ACTIVE	TYPE	DESCRIPTION
PWM0(P1.6)		OUTPUT	PWM 0 output
PWM1(P1.7)		OUTPUT	PWM 1 output

Table 16.1 PWM PIN define

16.1.1 PWM Registers

PWM0/1 is new design from AMICCOM. They can output pulse width modulation. User adjusts to duty cycle by setting PWMxH. PWM counter is up counter. PWM counter is not access directly by MCU. User can set or reset PWM counter by setting PWMxCON. When PWMxEN =1, PWM counter start to count. When PWMxEN=0, PWM counter stop counting and reload PWMxL to itself. PWxCLK is clock divider. It divide system clock to 2,4,8,16 ,32 and 64 by setting PWxCLK.

Address/Name	R/W	Bit 7	Bit 6	Bit 5	Bit 4	Bit 3	Bit 2	Bit 1	Bit 0

A9h PWM0CON	R/W	PWM0EN	-	-	-	-	PW0CLK2	PW0CLK1	PW0CLK0
Reset		0	0	0	0	0	0	0	0

PWM0CON: PWM channel 0 control register

PWM0EN: PWM Channel 0 Enable,

[0]: Disable. [1]: Enable.

PWM0CLK[2:0]: PWM Channel 0 Clock select

[000]: MCU Clock / 2

[001]: MCU Clock / 4

[010]: MCU Clock / 8

[011]: MCU Clock / 16

[100]: MCU Clock / 32

[101]: MCU Clock / 64

Address/Name	R/W	Bit 7	Bit 6	Bit 5	Bit 4	Bit 3	Bit 2	Bit 1	Bit 0
AAh PWM0H	R/W								
Reset		0	0	0	0	0	0	0	0

PWM0H: PWM channel 0 output HIGH register

Address/Name	R/W	Bit 7	Bit 6	Bit 5	Bit 4	Bit 3	Bit 2	Bit 1	Bit 0
ABh PWM0L	R/W								
Reset		0	0	0	0	0	0	0	0

PWM0L: PWM channel 0 frequency setting register

Address/Name	R/W	Bit 7	Bit 6	Bit 5	Bit 4	Bit 3	Bit 2	Bit 1	Bit 0
B0h PWM1CON	R/W	PWM1EN	-	-	-	-	PW1CLK2	PW1CLK1	PW1CLK0
Reset		0	0	0	0	0	0	0	0

PWM1CON: PWM channel 1 control register

PWM1EN: PWM Channel 1 Enable,

[0]: Disable. [1]: Enable.

PWM1CLK[2:0]: PWM Channel 1 Clock select

[000]: MCU Clock / 2

[001]: MCU Clock / 4

[010]: MCU Clock / 8

[011]: MCU Clock / 16

[100]: MCU Clock / 32

[101]: MCU Clock / 64

Address/Name	R/W	Bit 7	Bit 6	Bit 5	Bit 4	Bit 3	Bit 2	Bit 1	Bit 0
B1h PWM1H	R/W								
Reset		0	0	0	0	0	0	0	0

PWM1H: PWM channel 1 output HIGH register

Address/Name	R/W	Bit 7	Bit 6	Bit 5	Bit 4	Bit 3	Bit 2	Bit 1	Bit 0
B2h PWM1L	R/W								
Reset		0	0	0	0	0	0	0	0

PWM1L: PWM channel 1 frequency setting register

17. Watchdog Timer

A8105 has a special timer, called Watchdog Timer. It is a useful programmable clock counter that serves as a time-base generator, an event timer or system supervisor. User can use be a very long timer with disabled reset function.

17.1 Watchdog timer overview

As can be seen in the figure below, the watchdog timer is driven by the main system clock that is supplied to a series of dividers. The divider output is selectable and determines interval between timeouts. When the timeout is reached, an interrupt flag will cause an interrupt to occur if its individual enable bit is set and the global interrupt enable is set. The reset and interrupt are discrete functions that may be acknowledged or ignored, together or separately for various applications.

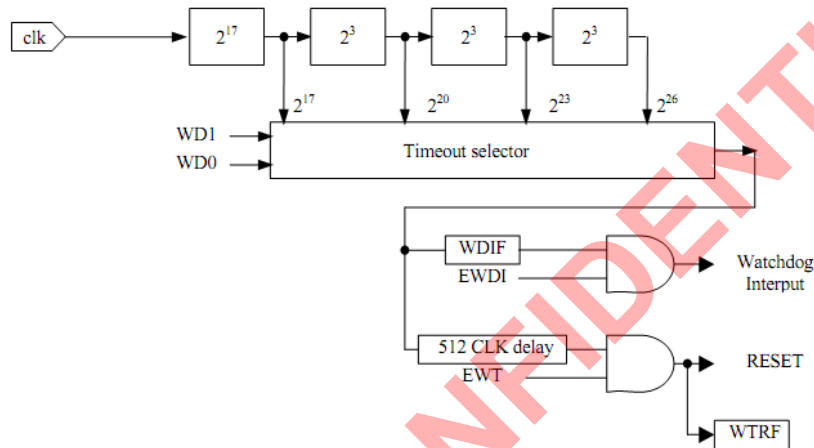

Figure 17.1 Watchdog Timer architecture

17.2 Watchdog interrupt

WATCHDOG interrupt related bits are shown below. An interrupt can be turned on/off by EIE register, and set into high/low priority group by EIP register. The IE contains global interrupt system disable (0) / enable (1) bit called EA.

IE register (0xA8)

Address/Name	R/W	Bit 7	Bit 6	Bit 5	Bit 4	Bit 3	Bit 2	Bit 1	Bit 0
A8h IE	R/W	EA	-	ET2	ES	ET1	EX1	ET0	EX0
Reset		0	0	0	0	0	0	0	0

EA : Enable global interrupts.

EIE (0xE8)

Address/Name	R/W	Bit 7	Bit 6	Bit 5	Bit 4	Bit 3	Bit 2	Bit 1	Bit 0
E8h EIE	R/W	EI2CS ESPI	EI2CM	EWDI	EKEYINT	ERFINT	EINT4	EINT3	EINT2
Reset		0	0	0	0	0	0	0	0

EWDI : Enable Watchdog interrupts

EIP (0xF8)

Address/Name	R/W	Bit 7	Bit 6	Bit 5	Bit 4	Bit 3	Bit 2	Bit 1	Bit 0
F8h EIP	R/W	PI2CS PSPI	PI2CM	PWDI	PKEYINT	PRFINT	PINT4	PINT3	PINT2
Reset		0	0	0	0	0	0	0	0

PWDI : Enable Watchdog priority level control (at 1-high-level)

Address/Name	R/W	Bit 7	Bit 6	Bit 5	Bit 4	Bit 3	Bit 2	Bit 1	Bit 0

D8h WDCON	R/W	-	-	-	-	WDIF	WTRF	EWT	RWT
Reset		0	0	0	0	0	0	0	0

WDIF : Watchdog Interrupt Flag. WDIF in conjunction with the Enable Watchdog Interrupt bit (EXIE.5), and EWT, indicates if watchdog timer event has occurred and what action should be taken. This bit must be cleared by software before exiting the interrupt service routine, or another interrupt is generated. Setting WDIF in software will generate a watchdog interrupt if enabled. Timed access registers procedure can be used to modify this bit.

All of bits that generate interrupts can be set or cleared by software, with the same result as if they had been set or cleared by hardware. That is, interrupts can be generated or pending interrupts can be cancelled by software. The Watchdog interrupt vector is located in 0x63. User can put interrupt service routine to take care watchdog interrupt event.

17.3 Watchdog Timer reset

The Watchdog Timer Reset function works as follows. After initializing the correct timeout interval, software first restarts the Watchdog using RWT and then enables the reset mode by setting the Enable Watchdog Timer Reset (WDCON.1) bit. At any time prior to reaching its user selected terminal value, software can set the Reset Watchdog Timer (WDCON.0) bit. If RWT is set before the timeout is reached, the timer will start over. If the timeout is reached without RWT being set, the Watchdog will reset the MCU. Hardware will automatically clear RWT after software sets it. When the reset occurs, the Watchdog Timer Reset Flag (WDCON.2) will automatically be set to indicate the cause of the reset, however software must clear this bit manually.

17.4 SIMPLE TIMER

The Watchdog Timer is a free running timer. When used as a simple timer with both the reset (EWT=0) and interrupt functions disabled (EWDI=0), the timer will continue to set the Watchdog Interrupt flag each time the timer completes the selected timer interval as programmed by WD[1:0]. Restarting the timer using the RWT bit, allows software to use the timer in a polled timeout mode. The WDIF bit is cleared by software or any reset. The Watchdog Interrupt is also available for applications that do not need a true Watchdog Reset but simply a very long timer. The interrupt is enabled using the Enable Watchdog Timer Interrupt (EIE.4) bit. When the timeout occurs, the Watchdog Timer will set the WDIF bit (WDCON.3), and an interrupt will occur if the global interrupt enable (EA) is set. **A potential Watchdog Reset is executed 512 clocks after setting of WDIF flag.** The Watchdog Interrupt Flag indicates the source of the interrupt, and software must clear WDIF flag. Proper use of the Watchdog Interrupt with the Watchdog Reset allows interrupt software to survey the system for errant conditions.

17.5 SYSTEM MONITOR

When using the Watchdog Timer as a system monitor, the Watchdog Reset function should be used. If the Interrupt function were used, the purpose of the watchdog would be defeated. For example, assume the system is executing errant code prior to the Watchdog Interrupt. The interrupt would temporarily force the system back into control by vectoring the MCU to the interrupt service routine. Restarting the Watchdog and exiting by an RETI or RET, would return the processor to the lost position prior to the interrupt. By using the Watchdog Reset function, the processor is restarted from the beginning of the program, and therefore placed into a known state.

17.6 WATCHDOG RELATED REGISTERS

The watchdog timer has several SFR bits that contribute to its operation. It can be enabled to function as either a reset source, interrupt source, software polled timer or any combination of the three. Both the reset and interrupt have status flags. The watchdog also has a bit that restarts the timer. A summary table showing the bit locations is below. A description follows.

Bit name	Register	Bit position	Description
EWDI	EIE	EIE.5	Enable Watchdog Timer Interrupt
PWDI	EIP	EIP.5	Priority of Watchdog Timer Interrupt
WD[1:0]	CKCON	CKCON.7-6	Watchdog Interval
RWT	WDCON	WDCON.0	Reset Watchdog Timer
EWT		WDCON.1	Enable Watchdog Timer Reset
WTRF		WDCON.2	Watchdog Timer Reset flag
WDIF		WDCON.3	Watchdog Interrupt flag

A Watchdog timeout reset will not disable the Watchdog Timer, but restarts the timer. In general, software should set the Watchdog to whichever state is desired, just to be certain of its state. Control bits that support Watchdog operation are described in next subchapters.

17.6.1. WATCHDOG CONTROL

Watchdog control bits are described below. Please note that access (write) to this register has to be performed using Timed access registers procedure.

Address/Name	R/W	Bit 7	Bit 6	Bit 5	Bit 4	Bit 3	Bit 2	Bit 1	Bit 0
D8h WDCON	R/W	-	-	-	-	WDIF	WTRF	EWT	RWT
Reset		0	0	0	0	0	0	0	0

WDIF : Watchdog Interrupt Flag.

WDIF in conjunction with the Enable Watchdog Interrupt bit (EXIE.5), and EWT, indicates if watchdog timer event has occurred and what action should be taken. This bit must be cleared by software before exiting the interrupt service routine, or another interrupt is generated. Setting WDIF in software will generate a watchdog interrupt if enabled. Timed access registers procedure can be used to modify this bit.

WTRF : Watchdog Timer Reset Flag.

When set by hardware, indicates that a watchdog timer reset has occurred. Set by software do not generate a watchdog timer reset. It is cleared by RESET pin, but otherwise must be cleared by software. The watchdog timer has no effect on this bit, when EWT bit is cleared.

EWT : Enable Watchdog Timer Reset.

The reset of microcontroller by watchdog timer is controlled by this bit. This bit has no effect on the ability of the watchdog timer to generate a watchdog interrupt. Timed Access procedure must be used to modify this bit.

0: watchdog timer timeout doesn't reset microcontroller

1: watchdog timer timeout resets microcontroller

RWT : Reset Watchdog Timer.

Setting RWT resets the watchdog timer count. Timed Access procedure must be used to set this bit before the watchdog timer expires, or a watchdog timer reset and/or interrupt will be generated if enabled.

17.6.2 CLOCK CONTROL

The Watchdog timeout selection is made using bits WD[1:0] as shown in the figure.

CKCON register (0x8E)

Address/Name	R/W	Bit 7	Bit 6	Bit 5	Bit 4	Bit 3	Bit 2	Bit 1	Bit 0
8Eh CKCON	R/W	WD1	WD0	T2M	T1M	T0M	MD2	MD1	MD0
Reset		0	0	0	0	0	0	0	0

Clock control register CKCON(0x8E) contains WD[1:0] bits select Watchdog timer timeout period. The Watchdog is clocked directly from CLK pin, and CKSE directly affects its timeout period. It is increased 256 times slower when the core is enabled CKSE. This allows the watchdog period to remain synchronized with device operation. Number of clocks needed for timeout does not depend on CKSE, and is constant as shown in table below. The Watchdog has four timeout selections based on the input CLK clock frequency as shown in the figure. The selections are a pre-selected number of clocks. Therefore, the actual timeout interval is dependent on the CLK frequency.

WD[1:0]	Watchdog interval	Number of clocks
00	2^{17}	131072
01	2^{20}	1048576
10	2^{23}	8388608
11	2^{26}	67108864

Note that the periods shown above are for the interrupt events. The Reset, when enabled, is generated 512 clocks later regardless of whether the interrupt is used. Therefore, the actual Watchdog timeout period is the number shown above plus 512 clocks (always CLK pin).

17.7 TIMED ACCESS REGISTERS

Timed Access registers have built in mechanism preventing them from accidental writes. TA is located at 0xEB SFR address. To do a correct write to such register the following sequence has to be applied:

```
CLR EA ;disable interrupt system
MOV TA, #0xAA
MOV TA, #0x55
```

; Any direct addressing instruction writing timed access register.
SETB EA ;Enable interrupt system

The time elapsed between first, second, and third operation does not matter (any number of Program Wait States is allowed). The only correct sequence is required. Any third instruction causes protection mechanism to be turned on. This means that time protected register is opened for write only for single instruction. Reading from such register is never protected. WDCON (D8h) is Timed Access register.

AMICCOM CONFIDENTIAL

18. ADC (Analog to Digital Converter)

A8105 has two built-in ADCs. One is 8-bits ADC do RSSI measurement as well as carrier detection function. The 8-bit ADC converting time is 20 x ADC clock periods. The other is 8-channel 12-bits SAR ADC.

18.1 8-bits ADC

Bit		Mode	
XADS	RSS	Standby	RX
0	1	None	RSSI / Carrier detect

Table 17.1 Setting of ADC function

Relative Control Register

Mode Control Register (Address: 0802h)

Bit	R/W	Bit 7	Bit 6	Bit 5	Bit 4	Bit 3	Bit 2	Bit 1	Bit 0
Name	R		ARSSI	AIF	CD	WWSE	FMT	FMS	ADCM
	W		ARSSI	AIF	DFCD	WWSE	FMT	FMS	ADCM
Reset			0	0	0	0	0	0	0

ADC Register (Address: 0821h)

Name	R/W	Bit 7	Bit 6	Bit 5	Bit 4	Bit 3	Bit 2	Bit 1	Bit 0
RSSI Threshold	R	ADC7	ADC6	ADC5	ADC4	ADC3	ADC2	ADC1	ADC0
	W	RTH7	RTH6	RTH5	RTH4	RTH3	RTH2	RTH1	RTH0
Reset		1	0	0	1	0	0	0	1

ADC Control Register (Address: 0822h)

Name	R/W	Bit 7	Bit 6	Bit 5	Bit 4	Bit 3	Bit 2	Bit 1	Bit 0
ADC Control	W	RSM1	RSM0	ERSS	FSARS	--	XADS	RSS	CDM
Reset		0	1	0	1	--	0	1	1

18.1.1 RSSI Measurement

A8105 supports 8-bits digital RSSI to detect RF signal strength. RSSI value is stored in ADC [7:0] (1Dh). Fig 17.1 shows a typical plot of RSSI reading as a function of input power. This curve is base on the current gain setting of A8105 reference code. A8105 automatically averages 8-times ADC conversion a RSSI measurement until A8105 exits RX mode. Therefore, each RSSI measuring time is (8 x 20 x F_{ADC}). Be aware RSSI accuracy is about ± 6dBm.

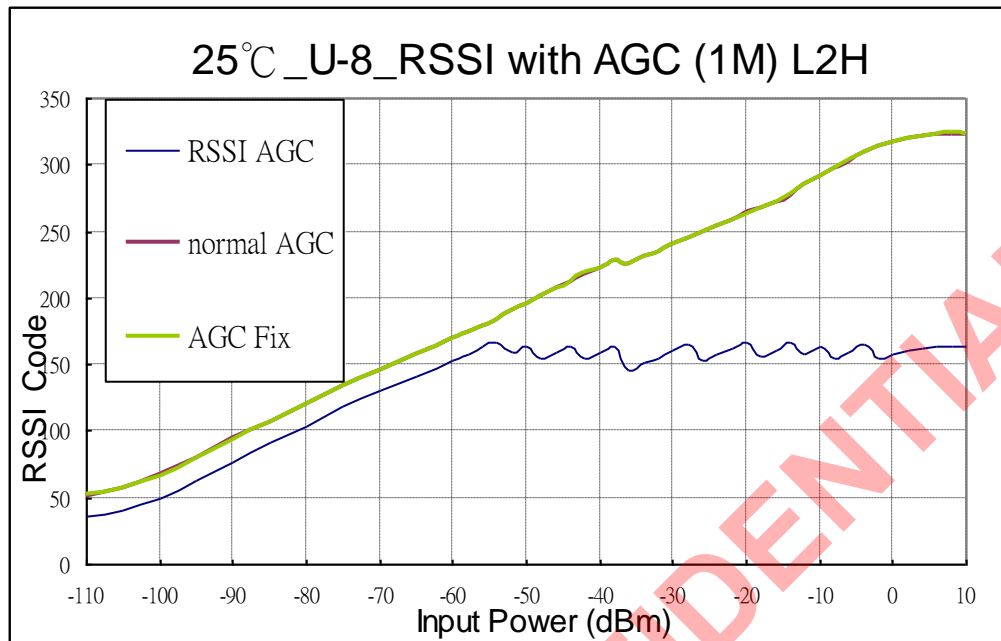

Figure 18.1 Typical RSSI characteristic.

Auto RSSI measurement for TX Power:

1. Set wanted F_{RXLO}
2. Set RSS= 1 (822h), FSARS= 1 (822h, 4MHz ADC clock).
3. Enable ARSSI= 1 (802h).
4. Send RX Strobe command.
5. In RX mode, 8-times average a RSSI measurement periodically.
6. Exit RX mode, user can read digital RSSI value from ADC [8:0] (1Dh) for TX power.

In step 6, if A8105 is set in direct mode, MCU shall let A8105 exit RX mode within 40 us to prevent RSSI inaccuracy.

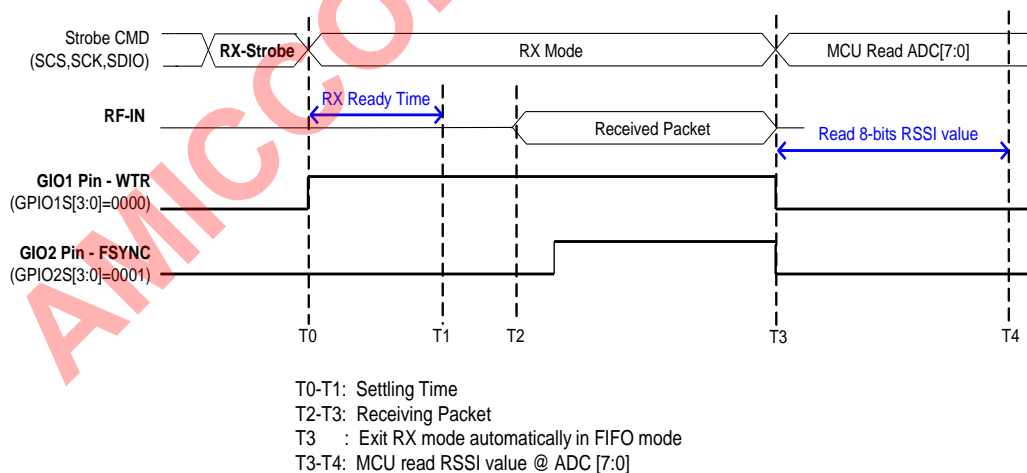
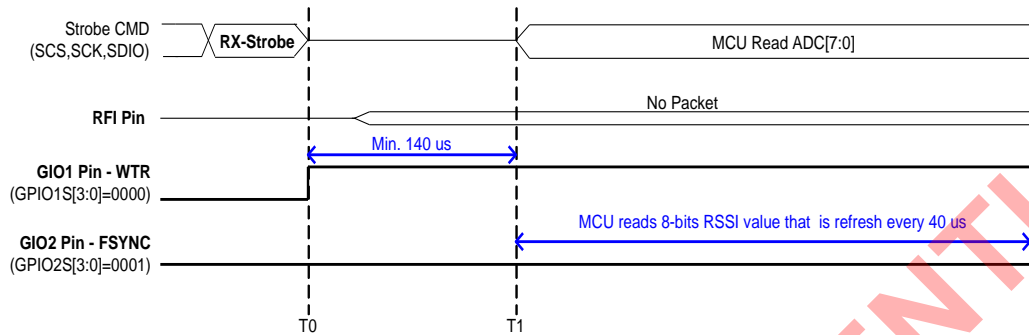

Figure 18.2 RSSI Measurement of TX Power.

Auto RSSI measurement for Background Power:

1. Set wanted F_{RXLO}
2. Set RSS= 1 (822h), FSARS= 0 (822h, 4MHz ADC clock).
3. Enable ARSSI= 1 (802h).
4. Send RX Strobe command.

5. MCU delays min. 140us.
6. Read digital RSSI value from ADC [8:0] (in 0x81DH and 0x821h) to get background power.
7. Send other Strobe command to let A8105 exit RX mode.



T0-T1: MCU Delay Loop from PLL to RX mode for RSSI measurement
 T1 : Auto RSSI Measurement is done by 8-times average.
 MCU can read RSSI value from ADC [7:0]

Figure 18.3 RSSI Measurement of Background Power.

18.1.2 Carrier Detect

Base on RSSI measurement, user can extend its application to do carrier detect (CD). In Carrier Detect mode, RSSI is refresh every 5 us without 8-times average. If RSSI level is below threshold level (RTH), CD is output high to GIO1 or GIO2 pin to inform MCU that current channel is busy.

Below is a reference procedure:

1. Set CDTH (0821h) for absolute RSSI threshold level (ex. RTH = 80d).
2. Set GIO2S = [0010] (080Eh) for Carrier Detect to GIO2 pin.
 - (2-1) Set wanted F_{RXLO}
 - (2-2) Set RSM= [11] (0822h, CDM =0 and hysteresis =6, or CDM =1 and hysteresis =12).
 - (2-3) Enable ARSSI= 1 (802h).
 - (2-4) Send RX Strobe command.
 - (2-5) MCU enables a timer delay (min. 100 us).
3. MCU checks GIO2 pin.
 - (3-1) If $ADC \geq CDTH$, GIO2 = 0.
 - (3-2) If $ADC \leq CDTH-CDM$, GIO2 = 1.
 - (3-3) If ADC locates in hysteresis zone, GIO2 = previous state.
4. Exit RX mode.

18.2 12-bits SAR ADC

A8105 includes a 12-bit successive approximation A/D converter which enables channel selection from 8 channels. The A/D converter has two operating modes: single mode and continuous mode. The 12-bits A/D converter can be used to perform the analog input of the specified channel or temperature sensor. Fig 18.5 shows a typical plot of temperature reading for 12-bit ADC.

Bit		Mode
DTMP	BUFS	
0	0	Analog Input
1	1	Temperature Sensor

Table 18.2 Setting of 12-bit ADC function

The conversion time in single mode can be determined as follows:

$$t_{conv} = \frac{1}{4MHz} \times \frac{1}{CKS[1:0]} \times 32$$

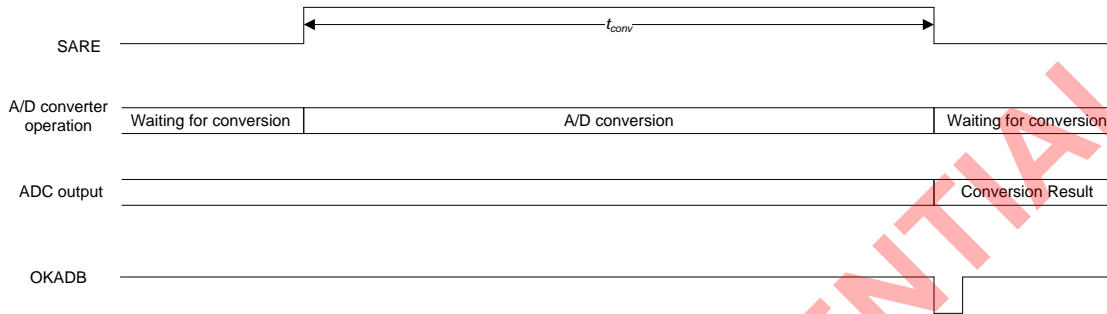

Figure 18.4 Single Mode for A/D Conversion.

Measurement for Analog Input:

1. Set ADCCH (0xBCh) for selecting ADC channel.
2. Set ENADC (0x85Bh) to enable the SAR ADC.
3. Set MODE (0x85Ah) to select single mode or continuous mode.
4. Enable ADCE = 1 (0x85Ah)

Measurement for Temperature:

1. Set ENADC (0x85Bh) to enable the SAR ADC.
2. Set BUFS = 1 (0x85Ah)
3. Set DTMP = 1 (0x85B) to enable the temperature sensor for 12-bit ADC.
4. Set MODE (0x85Ah) to select single mode or continuous mode.
5. Enable ADCE = 1 (0x85Ah)

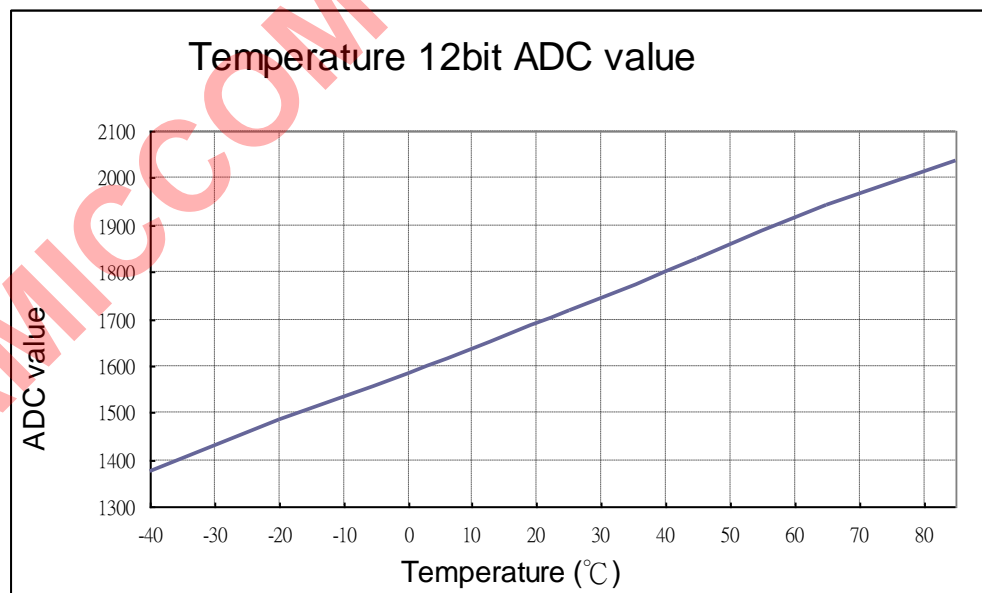

Figure 18.5 Typical 12-bit ADC temperature sensor characteristic curve.

19. Battery Detect

A8105 has a built-in battery detector to check supply voltage (REGI pin). The detecting range is 1.8V ~ 2.5V in 8 levels.

Relative Control Register

Battery detect Register (Address: 082Bh)

Name	R/W	Bit 7	Bit 6	Bit 5	Bit 4	Bit 3	Bit 2	Bit 1	Bit 0
Battery detect	W	RGS	RGV1	RGV0	PACTL	BVT2	BVT1	BVT0	BDS
	R	--	RGV1	RGV0	BDF	BVT2	BVT1	BVT0	BDS
Reset		0	0	0	0	0	1	1	0

BVT[1:0]: Battery detection threshold.

[000]: 1.8V. [001]: 1.9V. [010]: 2.0V. [011]: 2.1V.

[100]: 2.2V. [101]: 2.3V. [110]: 2.4V. [111]: 2.5V.

When REGI < Threshold, BDF= low.

When REGI > Threshold, BDF= high.

Below is the procedure to detect low voltage input (ex. below 2.1V):

1. Set A8105 in standby or PLL mode.
2. Set BVT[2:0] (082Bh) = [011] and enable BDS (082Bh) = 1.
3. After 5 us, BDE is auto clear.
4. MCU reads BDF (082Bh).
If REGI pin > 2.1V,
BDF = 1 (battery high). Else, BDF = 0 (battery low).

AMICCOM CONFIDENTIAL

20 Power Management

The power consumption of A8105 comes from two parts. One is RF part and the other is digital part (includes MCU core and peripherals). In the RF part, the idle mode use the minimum power and the TX or RX mode use the maximum power consumptions. Use changes RF status by setting the strobe control, register(0800h). For more detail information, please refer chapter 21.1. In this chapter only introduces digital parts. Low power operation is enabled through different power modes setting. A8105 has various operating mode are referred as normal mode, PM1, PM2, and PM3 (power manager mode 3). Table 20.1 shows the impact of different power modes on systems operation. There are two registers to setting power manager. One is power control register (PCON, 0x87h) and the other is power control extend register (PCONE, 0xB9h).

In normal mode, user selects different clock be MCU core clock.in CLKSEL[2:0] (PCONE, 0xB9h) then enable CKSE (PCON, 0x87h). User adjusts MCU clocks depends on the required power consumption. CLKSEL[2:0] = 001 ~ 110b, the MCU core clock is the clock sources divide 2 ~ 64. User could adjust the MCU speed to trade-off between the performance and the power consumption. **BEWARE, please choice CLKSEL firstly then enable CKSE to avoid glitch. Please refer the reference code or contact AMICCOM's FAE for more details.**

User can enable STOP to freeze MCU core clock and all digital peripherals also stop. MCU can be waked up by hardware reset, KEY wake up, KEYINT or sleep timer (WOR /TWOR). User set sleep timer, WOR or TWOR before enter STOP mode. In this condition, it is called PM1. In PM1, all digital circuitry is stop and RF circuitry is active by WOR

Note: Please don't enable STOP and CKSE at the same time.

PCON (087h) Power control

Address/Name	R/W	Bit 7	Bit 6	Bit 5	Bit 4	Bit 3	Bit 2	Bit 1	Bit 0
87h PCON	R/W	SMOD	-	-	PWE	-	SWB	STOP	CKSE
Reset		0	0	0	0	0	0	0	0

SWB (Switchback enable)

[1]: Enable

[0]: Disable

STOP (Stop mode)

[1]: Enable

[0]: Disable

CKSE (Clock select enable)

[1]: Enable clock select

[0]: Disable clock select

PCONE(0xB9h) Power control extend

Address/Name	R/W	Bit 7	Bit 6	Bit 5	Bit 4	Bit 3	Bit 2	Bit 1	Bit 0
B9h PCONE	R/W	-	-	QD	REGAE	PM2F	CLKSEL2	CLKSEL1	CLKSEL0
Reset		0	0	0	0	0	0	0	0

QD (Quick discharge) : Reserved for internal usage

REGAE(RegA Enable) : Reserved for internal usage

PM2F (Power Mode 2 flag) : Reserved for internal usage

CLKSEL[2:0] (Clock Select), Select clock source when enable clock select.

[000]: Clock source div 64 as MCU clock

[001]: Clock source div 2 as MCU clock

[010]: Clock source div 4 as MCU clock

[011]: Clock source div 8 as MCU clock

[100]: Clock source div 16 as MCU clock

[101]: Clock source div 32 as MCU clock

[110]: Clock source div 64 as MCU clock

[111]: Select RTC as CPU clock when CKSE=0; RTC div 2 as CPU clock when CKSE=1

	MCU speed	16MHz	RAM	Back to Normal	LVR	RF
Normal CKSE=0	16MHz	ON	ON	X	X	X
Normal CKSE=1 (Low speed)	8/4/2/1 MHz IRC/RTC	ON	ON	X	X	X
Idle (PM1)	OFF	OFF	ON	H/W reset / KEYINT / Sleep timer	X	OFF
Sleep (PM2)	OFF	OFF	ON	H/W reset / wakeup key / Sleep timer	X	OFF
Deep Sleep (PM3)	OFF	OFF	256K OFF 2K ON	H/W reset / wakeup key / Sleep timer	OFF	OFF

Table 20.1 Power manager

X: don't care, it can turn on or off by user setting
 Note: PM mode setting refer to chapter 9.2.101

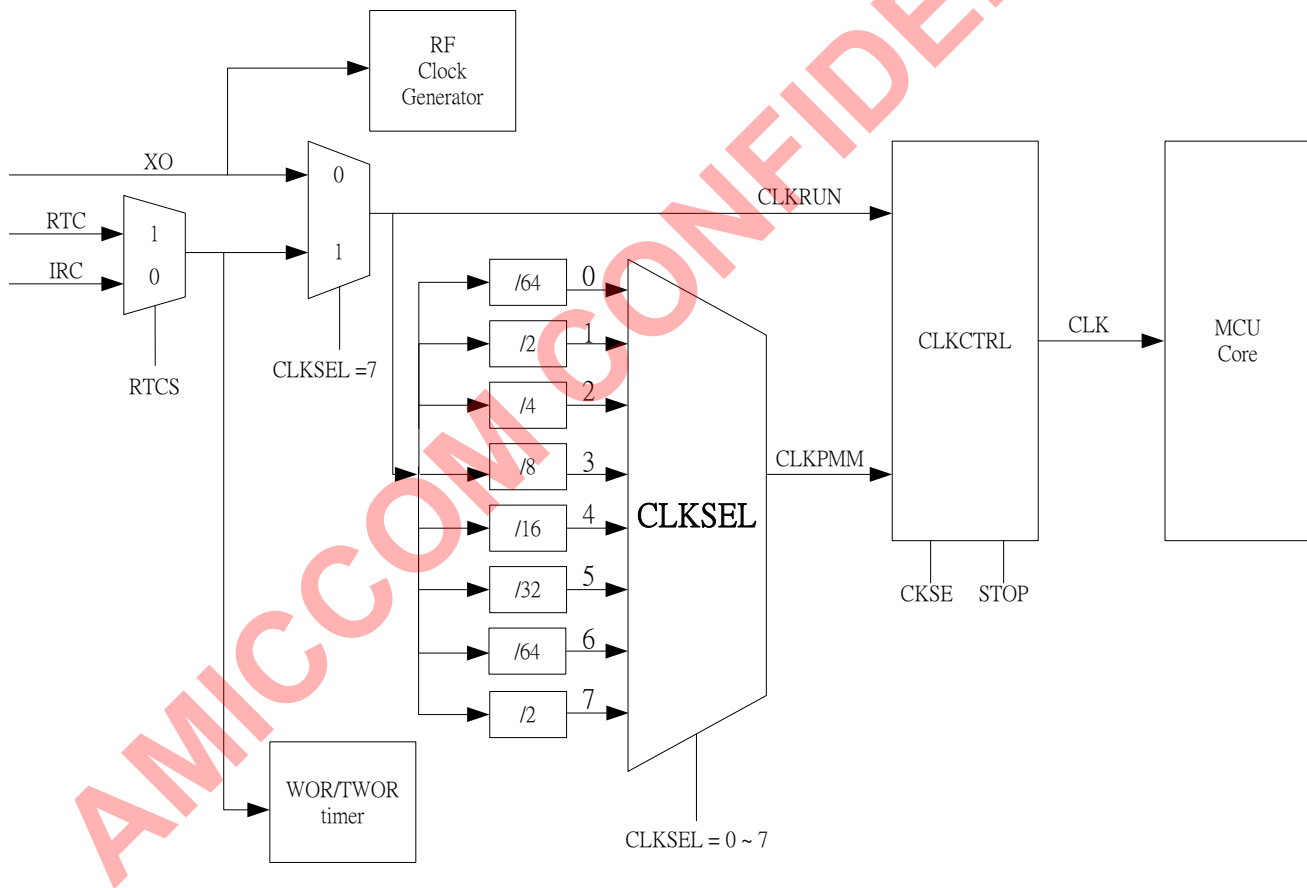

Figure 20.1 Whole chip clock sources

21 A8105 RF

A8105 integrate 2.4 Ghz GFSK transceiver and use Strobe control register (0800h) to control RF state. There are 6 Strobe commands to control internal state machine for RF operations. These modes include Sleep mode, Idle mode, Standby mode, PLL mode, RX mode and TX mode. There are 64Bytes FIFO for data transmitting, receiving. Sleep timer is used for WOR (Wake On Rx) and time-slotted mode operation.

21.1 Mode Control Register 1 (Address: 0x801h)

Name	R/W	Bit 7	Bit 6	Bit 5	Bit 4	Bit 3	Bit 2	Bit 1	Bit 0
MODEC1	W	STRB7	STRB6	STRB5	STRB4	STRB3	STRB2	STRB1	STRB0
Reset		1	0	1	0	0	0	0	0

Use strobe command control RF state.

STRB[7:0]: Strobe command register.

0x80: Sleep mode.

0x90: Idle mode.

0xA0: Standby mode.

0xB0: PLL mode.

0xC0: TX mode.

0xD0: RX mode.

Mode Register (Address: 0x800h)

Name	R/W	Bit 7	Bit 6	Bit 5	Bit 4	Bit 3	Bit 2	Bit 1	Bit 0
Mode	W	RESETN	FWPRN	FRPRN	ADC12RN		BFCRN		
	R	-	FECF	CRCF	CER	XER	PLLER	TRSR	TRER
Reset		--	--	--	--	--	--	--	--

In A8105, user can read the RF state from mode register

CER: RF chip enable status.

[0]: RF chip is disabled. **[1]:** RF chip is enabled.

XER: Internal crystal oscillator enabled status.

[0]: Crystal oscillator is disabled. **[1]:** Crystal oscillator is enabled.

PLLE: PLL enabled status.

[0]: PLL is disabled. **[1]:** PLL is enabled.

TRER: TRX state enabled status.

[0]: TRX is disabled. **[1]:** TRX is enabled.

TRSR: TRX Status Register.

[0]: RX state. **[1]:** TX state.

In A8105, user control RF mode as well as read/write ram. By DPTR access and MOVX instruction, user change RF mode and know RF status.

21.1.1 Strobe Command - Sleep Mode

Refer to Strobe Control Register, user can write 0x80 to Strobe Control Register directly to set RF into Sleep mode.

21.1.2 Strobe Command - Idle Mode

Refer to Strobe Control Register, user can write 0x90 to Strobe Control Register directly to set RF into Idle mode.

21.1.3 Strobe Command - Standby Mode

Refer to Strobe Control Register, user can write 0xA0 to Strobe Control Register directly to set RF into Standby mode.

21.1.4 Strobe Command - PLL Mode

Refer to Strobe Control Register, user can write 0xB0 to Strobe Control Register directly to set RF into PLL mode.

21.1.5 Strobe Command - RX Mode

Refer to Strobe Control Register, user can write 0xC0 to Strobe Control Register directly to set RF into RX mode.

21.1.6 Strobe Command - TX Mode

Refer to Strobe Control Register, user can write 0xD0 to Strobe Control Register directly to set RF into TX mode.

21.2 RF Reset Command

In addition to power on reset (POR), A8105 could issue software reset (80h) to RF by setting Mode Register (0800h). A8105 generates an internal signal "RESETN" to initial RF circuit. After reset command, RF state is in standby mode and re-calibration is necessary.

21.3 FIFO Accessing Command

Before TX delivery, user only needs to write wanted data into TX FIFO (0x900 ~ 0x93F) in advance. Similarly, user can read RX FIFO (0x900 ~ 0x93F) once payload data is received. It is easy to delivery data to air. Below is the procedure of writing TX FIFO.

- Step1: Send (n+1) bytes TX data in sequence by Data Byte 0, 1, 2 to n.
- Step2: Send TX Strobe command for transmitting.

There are similar steps to read RX FIFO.

- Step1: Send RX Strobe command for receiving data.
- Step2: Read RX data from RX FIFO in sequence by Data Byte 0, 1, 2 to n.

A8105 supports separated 64-bytes TX and RX FIFO. To use A8105's FIFO mode, user just needs to enable FMS =1 (01h). For FIFO accessing, TX FIFO (write-only) and RX FIFO (read-only) share the same register address 05h. TX FIFO represents transmitted payload. On the other hand, RX circuitry synchronizes ID Code and stores received payload into RX FIFO.

21.4 Packet Format of FIFO mode

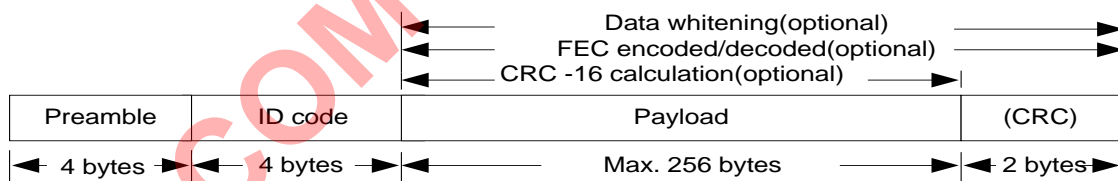

Figure 21.1 Packet Format of FIFO mode

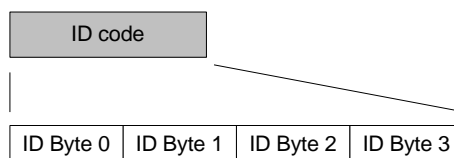

Figure 21.1 ID Code Format

Preamble:

The packet is led by preamble composed of alternate 0 and 1. If the first bit of ID code is 0, preamble shall be 0101...0101. In the contrast, if the first bit of ID code is 1, preamble shall be 1010...1010. Preamble length is recommended to set 4 bytes by PML [1:0] (20h).

ID code:

ID code is recommended to set 4 bytes by IDL=1 (20h). ID Code is sequenced by Byte 0, 1, 2 and 3. If RX circuitry checks the ID code correct, payload will be written into RX FIFO. In special case, ID code could be set error tolerance (0~ 3bit error) by ETH [1:0] (21h) for ID synchronization check.

Payload:

Payload length is programmable by FEP [7:0] (03h). The physical FIFO depth is 64 bytes. A8105 also supports logical FIFO extension up to 256 bytes. See section 16.5 for details.

CRC (option):

In FIFO mode, if CRC is enabled (CRCS=1, 20h), 2-bytes of CRC value is transmitted automatically after payload. In the same way, RX circuitry will check CRC value and show the result to CRC Flag (00h).

21.5 Transceiver Frequency

A8105 is a half-duplex transceiver with embedded PA and LNA. The receiver is a low-IF architecture consisting of a LNA, down conversion mixers, polyphase channel filters and IF limiting amplifiers with RSSI. The transmitter is direct modulation architecture with 6 dBm maximum output power and 35 dB power control range. For TX or RX frequency setting, user just needs to set up one register, CHN (0811h), for frequency agility.

A8105's main PLL features are:

- Fractional-N to generate RX/TX frequencies for all ISM 2.4 GHz channels
- Autonomous calibration loops for stable operation within the operating range
- Fast PLL settling to support frequency hopping

During receive operation, the frequency synthesizer works as a local oscillator. During transmit operation, the voltage-controlled oscillator (VCO) is directly modulated to generate the RF transmit signal. The frequency synthesizer is implemented as a fractional-N PLL.

$F_{LO} = 2400 + (CHN \times 0.5)$ in [MHz], where CHN is the channel number, addr 0Fh.

A8105's LO frequency $F_{LO} = F_{LO_BASE} + F_{OFFSET}$. Therefore, A8105 is very easy to implement frequency hopping by **ONE register setting, (CHN, 0Fh)**. In general, user can plan the wanted channels by a CHN Look-Up-Table between master and slaves for two-way frequency hopping. Below is the LO frequency block diagram.

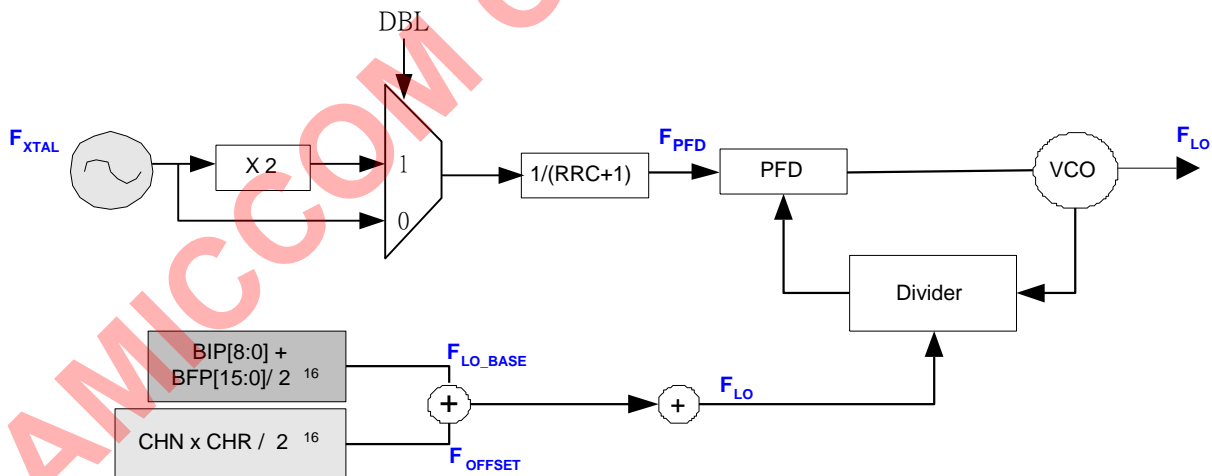

Figure 21.2 Block Diagram of Local Oscillator

21.5.1 RF Clock

The master clock of A8105 ($F_{CCLK} = 32/64$ MHz) is generated by the PLL clock generator which reference frequency ($F_{CGR} = 2/4$ MHz) is derived from frequency divider of crystal oscillator.

$$F_{CGR} = \frac{F_{XREF}}{(GRC[3:0] + 1)}, \text{ where } GRC [3:0] (0Eh) \text{ is the divide number to get } F_{CGR} \text{ from crystal oscillator.}$$

Below is block diagram of system clock where F_{XTAL} is the crystal frequency. User can set XS, GRC, CGS to get $F_{CSCK} = 32/64\text{MHz}$. F_{XREF} is a reference clock to generate F_{CGR} and F_{SPLL} . After delay circuitry, F_{CSCK} (32/64MHz) is derived. And with BWS setting, the system clock F_{SYCK} can be fixed to 8MHz.

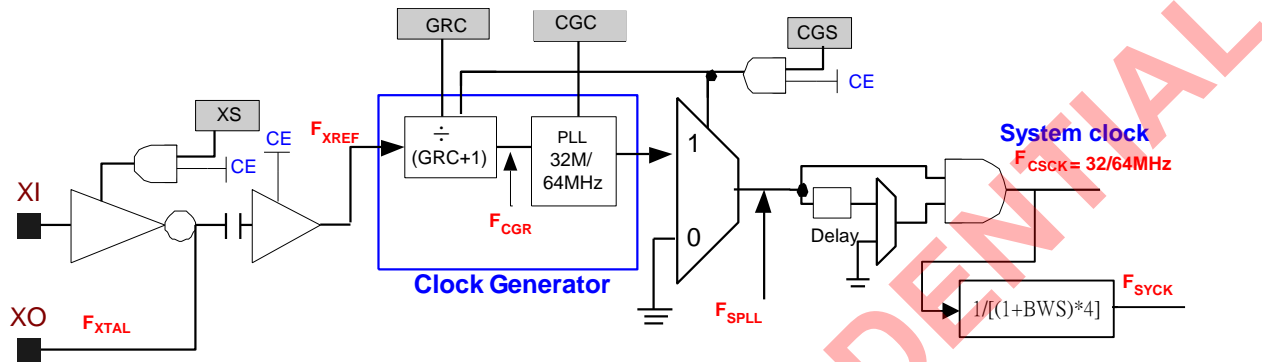

Figure 21.3 RF Clock Block Diagram

Below is the setting table of system clock for both 1MHz and 2MHz data rate

Data rate	F _{XTAL}	F _{XREF}	F _{CGR}	GRC [3:0]	XS	CGS	CGC	BWS	F _{CSCK}	F _{SYCK}
1M	16 MHz	16 MHz	2 MHz	[0111]	1	1	0	0	32MHz	8MHz
2M	16 MHz	16 MHz	2 MHz	[0011]	1	1	1	1	64MHz	8MHz

21.5.2 LO Frequency Setting

To set up 2.4GHz LO Frequency (F_{LO}), user can refer to below 4 steps.

1. Set the base frequency (F_{LO_BASE}) by PLL Register II (0812h) and III (0813h). Recommend to set $F_{LO_BASE} \sim 2400.001\text{MHz}$.
2. Set channel step $F_{CHSP} = 500\text{kHz}$ by PLL Register IV (0814h).
3. Set CHN [7:0] to get offset frequency by PLL Register I (0811h). $F_{OFFSET} = \text{CHN [7:0]} * F_{CHSP}$
4. LO frequency is equal to base frequency plus offset frequency. $F_{LO} = F_{LO_BASE} + F_{OFFSET}$



21.5.2.1 How to set F_{LO_BASE}

Regarding to LO frequency setting, Table 21.1 shows 2400.001 MHz base frequency by 16MHz Xtal.

STEP	ITEMS	VALUE	NOTE
1	F _{XTAL}	16 MHz	Crystal Frequency
2	BIP[7:0]	0x96	To get F _{LO_BASE} = 2400 MHz
3	BFP[15:0]	0x0004	To get F _{LO_BASE} ~ 2400.001 MHz
4	F _{LO_BASE}	~2400.001 MHz	LO Base frequency

Table 21.1 How to configure F_{LO_BASE}

21.5.2.2 How to set F_{LO} = F_{LO_BASE} + F_{OFFSET}

Regarding to frequency offset scheme, Table 21.2 shows Channel 11 (2405.001 MHz) by 16MHz Xtal.

STEP	ITEMS	VALUE	NOTE
1	F _{LO_BASE}	~2400.001 MHz	After cofigure BIP and BFP
2	CHR[14:0]	0x0800	To get F _{CHSP} = 500 KHz
3	CHN[7:0]	0x0A	To set channel number = 10
4	F _{OFFSET}	5 MHz	To get F _{OFFSET} = 500 KHz * (CHN) = 5MHz
5	F _{LO}	~2405.001 MHz	To get F _{LO} = F _{LO_BASE} + F _{OFFSET}

Table 21.2 How to configure F_{LO}

21.6 State machine

In chapter 9.2 and chapter 21.1, user can learn both accessing A8105's control registers as well as issuing Strobe commands.

21.6.1 Key states

A8105 supports 6 key operation states. Those are,

- (1) Standby mode
- (2) Sleep mode
- (3) Idle mode
- (4) PLL mode
- (5) TX mode
- (6) RX mode

After power on reset or software reset or deep sleep mode, user has to do calibration process because all control registers are in initial values. The calibration process of A8105 is very easy, user only needs to issue Strobe commands and enable calibration registers. After calibration, A8105 is ready to do TX and RX operation. User can start wireless transmission.

Strobe Command								Description
b7	b6	b5	b4	b3	b2	b1	b0	
1	0	0	0	x	x	x	x	Sleep mode
1	0	0	1	x	x	x	x	Idle mode
1	0	1	0	x	x	x	x	Standby mode
1	0	1	1	x	x	x	x	PLL mode
1	1	0	0	x	x	x	x	RX mode
1	1	0	1	x	x	x	x	TX mode

Mode	RF Register retention	RF Regulator	Xtal Osc.	VCO	PLL	RX	TX	Strobe Command
Sleep	Yes	ON	OFF	OFF	OFF	OFF	OFF	(1000-xxxx)b
Idle	Yes	ON	OFF	OFF	OFF	OFF	OFF	(1001-xxxx)b
Standby	Yes	ON	ON	OFF	OFF	OFF	OFF	(1010-xxxx)b
PLL	Yes	ON	ON	ON	ON	OFF	OFF	(1011-xxxx)b
TX	Yes	ON	ON	ON	ON	OFF	ON	(1101-xxxx)b
RX	Yes	ON	ON	ON	ON	ON	OFF	(1100-xxxx)b

Remark: x means “don't care”

Table 21.3 Operation mode and strobe command

21.6.2 FIFO mode

This mode is suitable for the requirements of general purpose applications and can be chosen by setting FMS = 1. After calibration, user can issue Strobe command to enter standby mode where write TX FIFO or read RX FIFO. From standby mode to packet data transmission, only one Strobe command is needed. Once transmission is done, A8105 is auto back to standby mode. Figure 21.4 and Figure 21.5 are TX and RX timing diagram respectively. Figure 21.6 illustrates state diagram of FIFO mode.

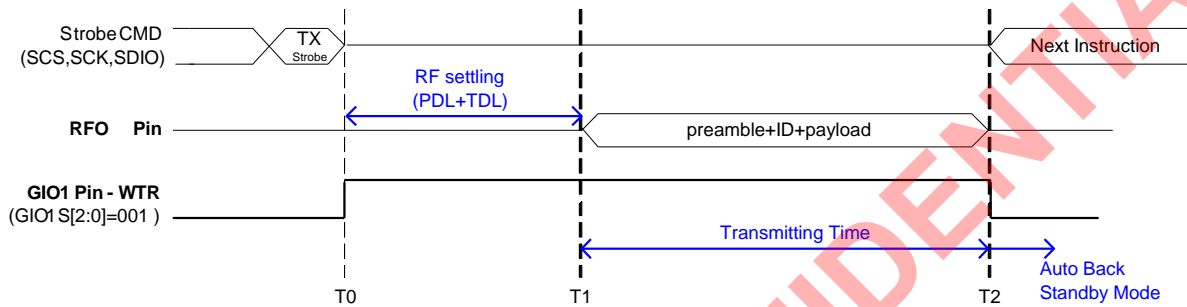

Figure 21.4 TX timing of FIFO Mode

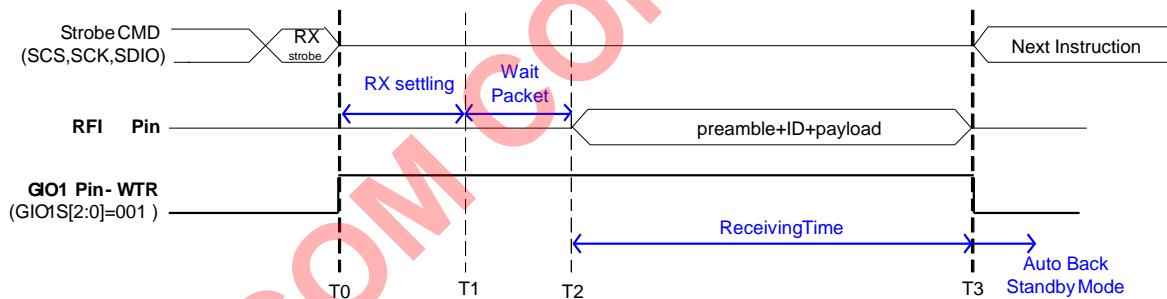

Figure 21.5 RX timing of FIFO Mode

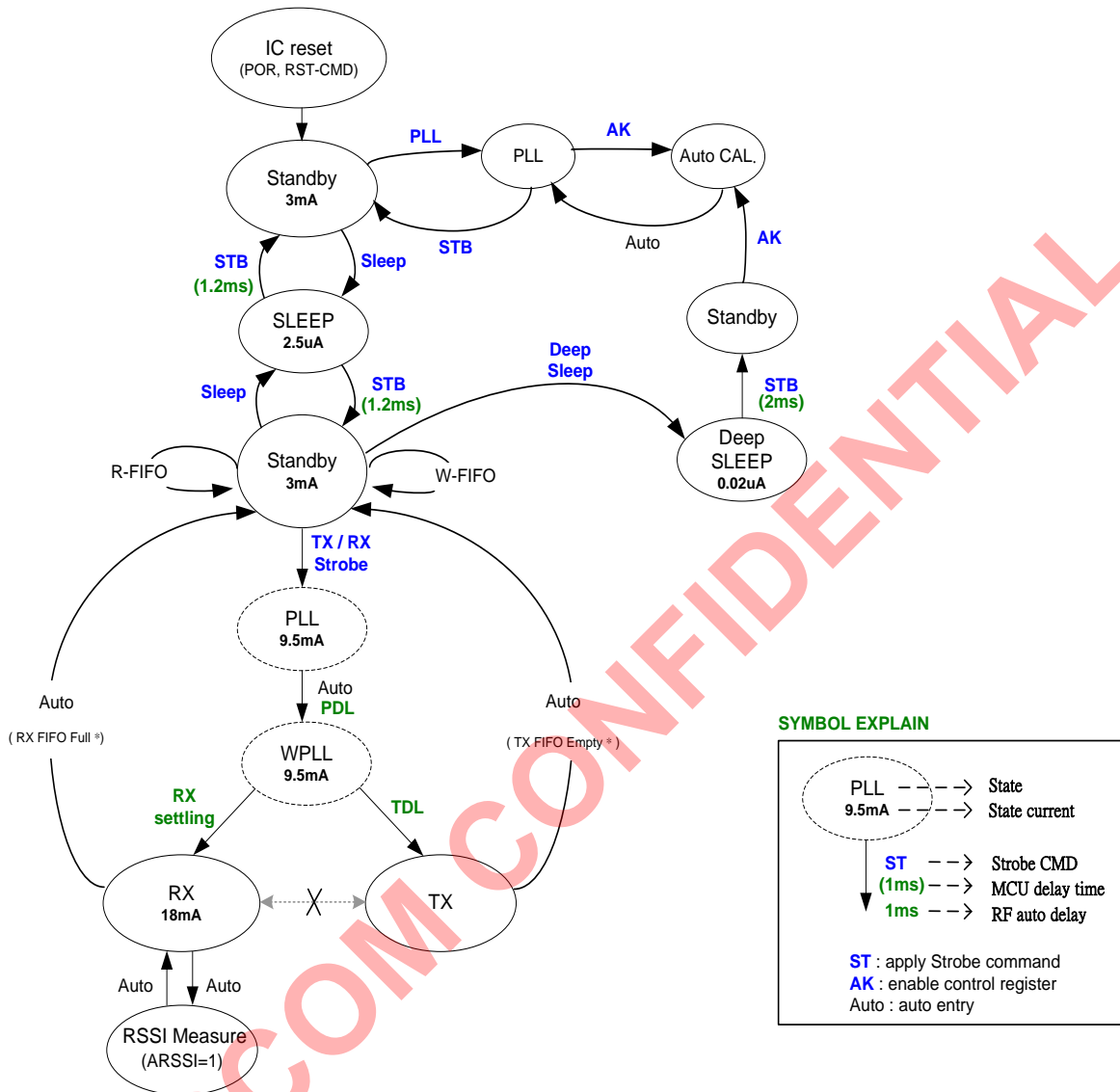

Figure 21.6 State diagram of FIFO Mode

22. Encryption and Authentication

For Bluetooth Low Energy application, it uses AES-128 link layer encryption block with Counter Mode CBC MAC defined in IETF RFC 3610. A8105 32Kbytes version (A8105F5) integrates AES-128 encryption core for user to encrypt data using AES algorithm with 128-bits key. The AES core also supports CBC-MAC for authentication.

22.1 AES

AES (Advanced Encryption Standard) is a symmetric block cipher on 128-bits data blocks, it consists 10 encryption rounds during encryption process. Figure 22.1 shows the structure of the AES encryption. AES can be divided into four basic operation block where data are treated at either byte or bit level. The array of bytes organized as a 4x4 matrix is also called "state" and those four basic steps, AddRoundKey, SubBytes, ShiftRows, and MixColumns. These four steps describe one round of the AES operation. The number of rounds is depended on the key length, i.e., 10, 12, and 14 rounds for the key length of 128, 192, and 256 bits respectively. The block diagram of the AES with 128 bit data is shown below in Figure 22.1.

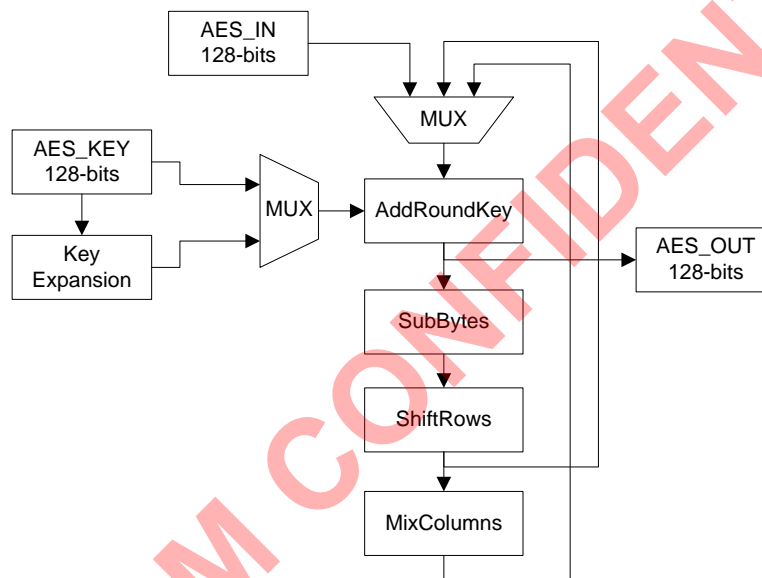

Figure 22.1 Structure of the AES-128 Core.

22.1.1 AddRoundKey

Each byte of the array is added to a byte of the corresponding array of round subkeys. Excluding the first and the last round, the AES with 128-bits round key proceeds for 9 iterations. Round keys are generated by a procedure called round key expansion or key scheduling. Those sub-keys are derived from the original key by XOR the two previous columns. For columns that are in multiples of four, the process involves round constants addition, S-Box and shift operations.

22.1.2 SubBytes

This operation is a non-linear byte substitution. It composes of two sub-transformations; multiplicative inverse and affine transformation. In most implementations, these two sub-steps are combined into a single table lookup called S-Box.

22.1.3 ShiftRows

This step is a simple permutation process, operates on individual rows, i.e. each row of the array is rotated by a certain number of byte positions.

22.1.3 MixColumns

The MixColumns transformation is a substitution step that makes of arithmetic over $GF(2^8)$. Column vector is multiplied by a fixed matrix where bytes are treated as a polynomial of degree less than 4.

22.2 CCM

CCM is an authenticated encryption algorithm designed to provide both authentication and confidentiality. It is only defined for block ciphers with a block length of 128 bits. It uses encryption algorithm to generate encrypted and authenticated data at the same time. The AES-CCM process is shown in Figure 22.2.

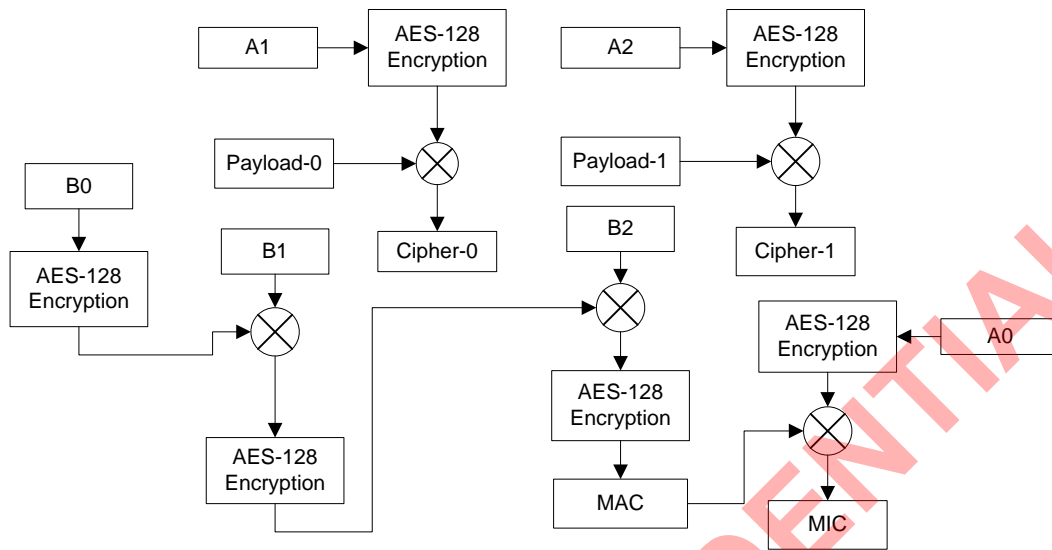

Figure 22.2 CCM Encryption Procedure.

CCM authentication starts by defining a sequence of blocks B_0 , B_1 , and B_2 and thereafter CBC-MAC is applied to those blocks so that the authentication field MIC can be obtained. CCM uses the A_0 , A_1 , and A_2 blocks to generate key-stream that is used to encrypt the MIC and the payload. Block A_0 is always used to encrypt and decrypt the MIC. A_1 and A_2 blocks are generated as needed for encryption or decryption of the payload.

23. Flash memory controller

SFR RELATED REGISTERS

FLASH memory is controlled using PCON(0x87)'s PWE bit, FLSHCTRL(0x9A) and FLSHTMR (0x9B), FLSHTPG(0x9C) and FLSHTER(0x9D). An SFR register named FLASHCTRL (0x9A) is used to control communication between CPU and flash. FLSHCTRL(0x9A) is consisted of 6bits used to control all FLASH related operations. Lower five bits of FLSHTMR (0x9B) named FREQ[4:0] determine real CLK frequency with 1MHz step resolution. FREQ[4:0] after reset is set to 20MHz by default, provides optimal timing for flash macro. Please contact AMICCOM FAE for more details flash operation reference code.

Address/Name	R/W	Bit 7	Bit 6	Bit 5	Bit 4	Bit 3	Bit 2	Bit 1	Bit 0
9Ah FLSHCTRL	R/W	CTRL.7	CTRL.6	CTRL.5	CTRL.4	CTRL.3	CTRL.2	CTRL.1	CTRL.0
Reset		0	0	0	0	0	0	0	0

Address/Name	R/W	Bit 7	Bit 6	Bit 5	Bit 4	Bit 3	Bit 2	Bit 1	Bit 0
9Bh FLSHTMR	R/W				Fewq.4	Fewq.3	Fewq.2	Fewq.1	Fewq.0
Reset		0	0	0	0	0	0	0	0

FREQ[4:0]	Frequency MHz
0x00	-
0x01	1
0x02	2
...	...
0x14	20

Table 3. FREQ intervals

Address/Name	R/W	Bit 7	Bit 6	Bit 5	Bit 4	Bit 3	Bit 2	Bit 1	Bit 0
9Ch FLSHTPG	R/W								
Reset		0	0	1	0	0	1	1	1

Address/Name	R/W	Bit 7	Bit 6	Bit 5	Bit 4	Bit 3	Bit 2	Bit 1	Bit 0
9Dh FLSHTER	R/W								
Reset		1	1	1	1	1	0	0	1

Setting higher clock frequency is not supported since given Flash macro has limited its clock frequency up to 20MHz by T_{kp} read cycle time. FLASHCTRL register is write protected by TA enable procedure listed below:

CLR EA ;disable interrupt system

MOV TA, #0xAA

MOV TA, #0x55

MOV FLASHCTRL,#<value> ; Any direct addressing instruction writing FLASHCTRL register.

SETB EA ;Enable interrupt system

The Program Write Enable (PWE) bit, located in PCON register, is used to enable/ disable PRGROMWR and PRGRAMWR pin active during MOVX instructions.

PCON (087h) Power control

Address/Name	R/W	Bit 7	Bit 6	Bit 5	Bit 4	Bit 3	Bit 2	Bit 1	Bit 0
87h PCON	R/W	SMOD	-	-	PWE	-	SWB	STOP	CKSE
Reset		0	0	0	0	0	0	0	0

When PWE bit is set to logic 1, the MOVX @DPTR,A instruction writes data located in accumulator register in to Program Memory addressed by DPTR register (active: DPH:DPL). The MOVX @ Rx,A instruction writes data located in accumulator register into program memory addressed by P2 register (bit 15:8) and Rx register (bit 7:0). Program Memory can be read by MOVX only regardless of PWE bit.

CHIP ERASE OPERATION

Chip erase operation is enabled by setting CTRL[5:0]=0x04 of FLSHCTRL register according to MCU TA enable procedure. PCON.PWE bit must be also set, then first MOVX instruction writing to program memory space at address belong to certain FLASH macro begins sector erase operation. During erase operation MCU is halted by asserting FLASHBUSY pin. When FLASH macro is blank and ready for new programming. To erase another FLASH macro, the whole procedure needs to be repeated with change MOVX address pointing to certain FLASH macro. Preprogramming of whole FLASH macro is executed automatically without any interaction with user, before real chip erase. It extends lifecycle of FLASH macro.

SECTOR ERASE OPERATION

The 16KB Flash macro has 129 sectors (128Bytes each) which can be erased separately. Sector erase operation is enabled by setting CTRL[5:0] = 0x22 of FLSHCTRL register according to MCU TA enable procedure. PCON.PWE bit must be also set. The first MOVX instruction writing to program memory space at selected sector address begins sector erase operation. During sector erase operation, MCU is halted by asserting FLASHBUSY pin. When sector has been erased, FLASHBUSY pin is deactivated and FNOP is automatically written. MCU executes next instruction. Selected FLASH macro sector(s) is blank and ready for new programming. To erase another sectors whole procedure needs to be repeated. Programming of whole sector is executed automatically without any interaction with user, before real erase. It extends lifecycle of FLASH macro.

PROGRAM OPERATION

Word program operation is enabled by setting CTRL[5:0]=0x01 of FLSHCTRL register according to MCU TA enable procedure. PCON.PWE bit must be set too, then each write to program memory space by MOVX instruction addressing odd bytes begins word program operation. During program operation MCU is halted by asserting FLASHBUSY pin. When word has been programmed FLASHBUSY pin is deactivated. MCU executes next instruction which can be (i) programming of next memory word (ii) CTRL[5:0] = 0x00 according to MCU TA enable procedure. Number of programmed bytes must be always even number(2,4,6...) . For example to program byte at address 0x003, first must be written byte at address 0x002 then second MOVX instruction write at address 0x003 begins physical write to FLASH macro. When number of programmed bytes is not even then it must be filled with extra neutral byte. The neutral bytes does not program any bit in a FLASH macro. **Note: Flash memory can programmed once. Please erase sector firstly if change the content in the flash memory.**

24 In Circuit Emulator (ICE)

A8105 support In Circuit Emulator on chip. It is a real-time hardware debugger as a non-intrusive system. It doesn't need to occupy any hardware resource such as the UART and Timer. User develops firmware complete producing code without any modification using ICE. It helps user to track down hidden bugs within the application running with microcontroller. The ICE with Hardware USB dongle provides a powerful SOC development tool with silicon using 2-wire protocol. The ICE fully supports Keil uVision2/3/4 interface to hardware debuggers. It allows Keil software user to work with uvision2/3/4. For more detail information, please reference Application note.

24.1 PIN define

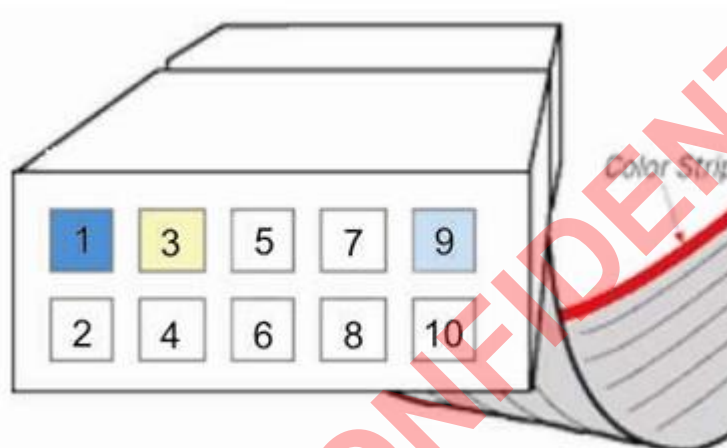

Fig 24.1 The USB connectors

Pin	Signal name	Description	Pin	Signal name	Description
1	ttck	Clock signal (in)	2	GND	Signal Ground
3	ttdio	Data (io)	4	VCCIO	Used to VCCIO detection
5	NU	Do not use	6	NU	Do not use or connect
7	NU	Do not use	8	NU	Do not use or connect
9	rsto	Reset output (od)	10	GND	Signal Ground

Fig22.2 The Pin define within USB connector

Note: RSTO pin is open drain (od) type active low. It forces logic zero to issue reset. When RSTO is inactive its output is floating, and should be connected to global system reset with pull-up resistor. This pin can be left unconnected.

There are 10 pin in the ICE connectors. 2-wire ICE only use 2 pins (PIN1 and PIN3). The PIN9 is optional and it can connect reset signal. PIN2 and PIN10 are GND pin. PIN4 is VCCIO pin. The recommended circuit shows as the below figure. (Fig21.3). There is a resistor (100 ohm) between A8510 and pin connected the connector.

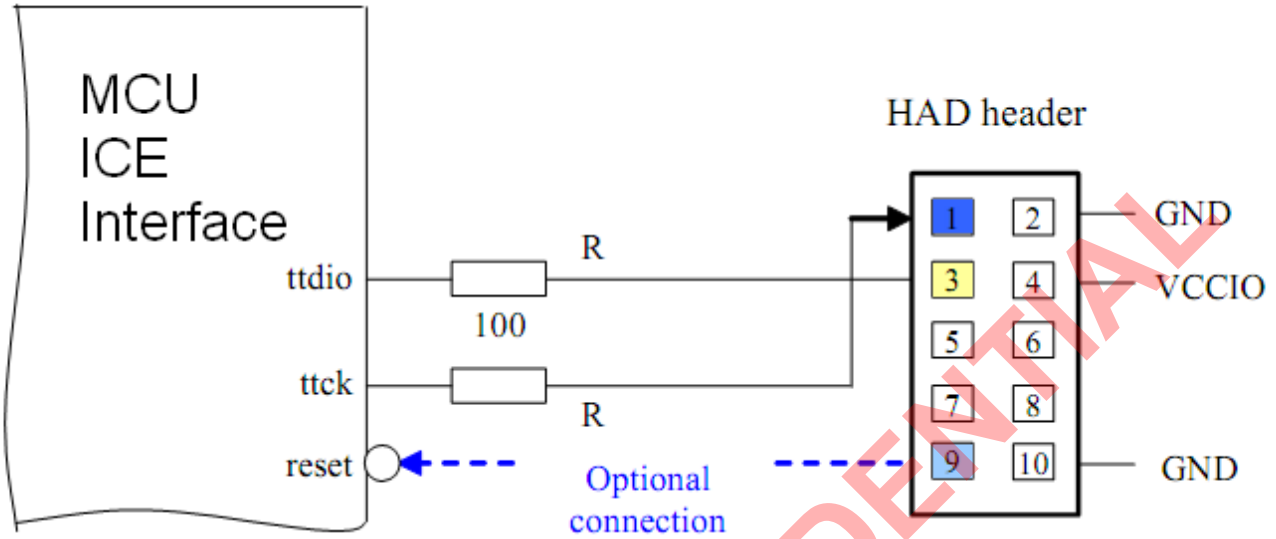

Fig 24.3 The connections between A8105 and USB connectors

24.2 ICE Key feature

The ICE supports source level debugging, 2 hardware breakpoint, auto refresh of all register and In System Programming (ISP). User can use ICE to download firmware by Keil software or AMICCOM tool.

AMICCOM CONFIDENTIAL

25. Application circuit

Below are AMICCOM's ref. design circuits. For more details, please refer AMICCOM standard module , MD8105-Axx.

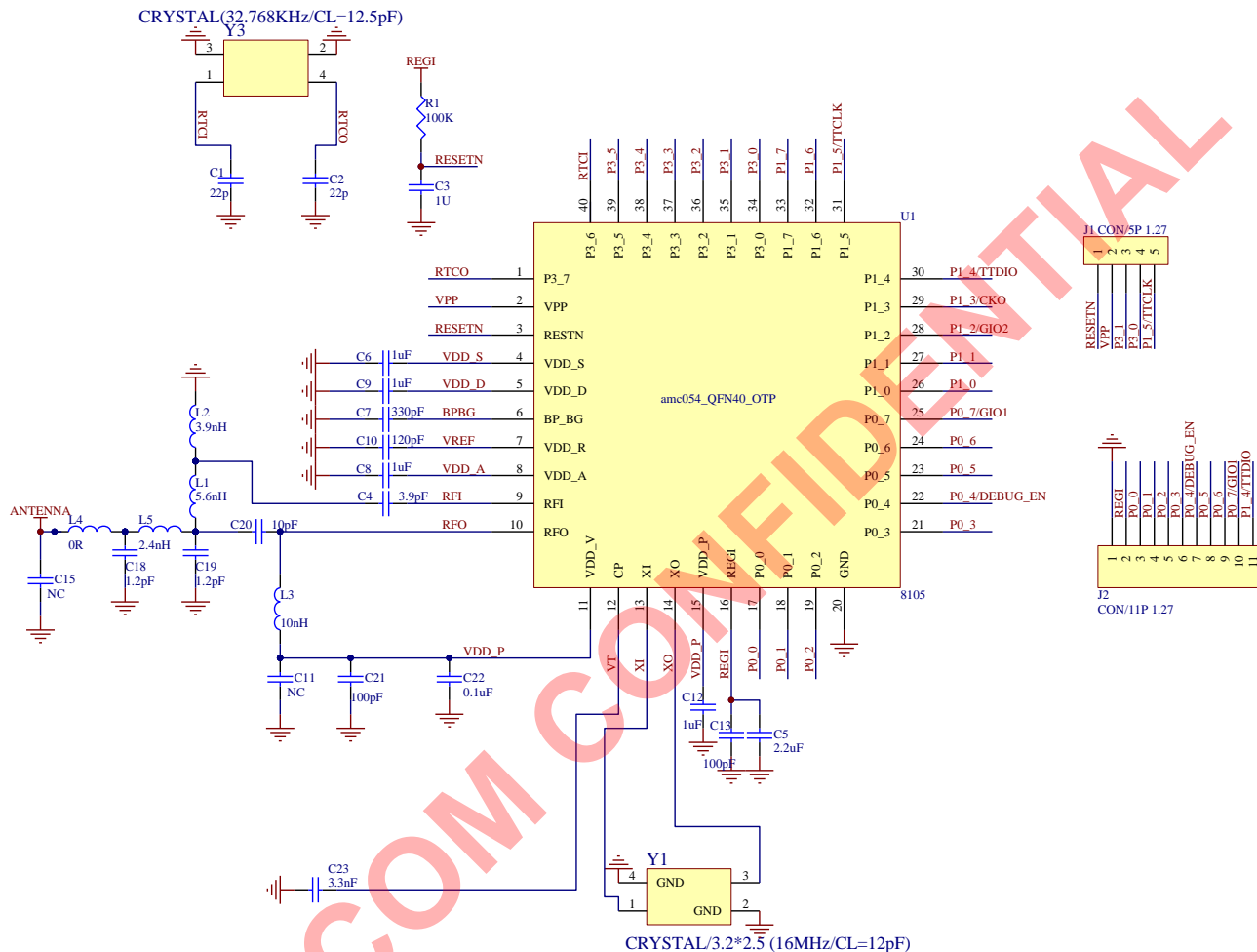

26. Abbreviations

ADC	Analog to Digital Converter
AIF	Auto IF
FC	Frequency Compensation
AGC	Automatic Gain Control
BER	Bit Error Rate
BW	Bandwidth
CD	Carrier Detect
CHSP	Channel Step
CRC	Cyclic Redundancy Check
DC	Direct Current
FEC	Forward Error Correction
FIFO	First in First out
FSK	Frequency Shift Keying
ID	Identifier
ICE	In Circuit Emulator
I ² C	Inter-Integrated Circuit
IF	Intermediate Frequency
ISM	Industrial, Scientific and Medical
LO	Local Oscillator
MCU	Micro Controller Unit
PFD	Phase Frequency Detector for PLL
PLL	Phase Lock Loop
POR	Power on Reset
PWM	Pulse width modulation
RX	Receiver
RXLO	Receiver Local Oscillator
RSSI	Received Signal Strength Indicator
SPI	Serial to Parallel Interface
SYCK	System Clock for digital circuit
TX	Transmitter
TXRF	Transmitter Radio Frequency
UART	Universal Asynchronous Receiver/Transmitter
VCO	Voltage Controlled Oscillator
XOSC	Crystal Oscillator
XREF	Crystal Reference frequency
XTAL	Crystal

AMICCOM CONFIDENTIAL

27. Ordering Information

Part No.	Package	Units Per Reel / Tray
A8105F5 (32KB)		
A81X05F5009AQ6C/Q	QFN48L, Pb Free, Tape & Reel, -40°C ~ 85°C	3K
A81X05F5009AQ6C	QFN48L, Pb Free, Tray, -40°C ~ 85°C	490EA
A81X05F5001AQ5A/Q	QFN40L, Pb Free, Tape & Reel, -40°C ~ 85°C	3K
A81X05F5001AQ5A	QFN40L, Pb Free, Tray, -40°C ~ 85°C	490EA
A81X05F5001AH	Die form, -40°C ~ 85°C	100EA
A8105F4 (16KB)		
A81X05F4001AQ5A/Q	QFN40L, Pb Free, Tape & Reel, -40°C ~ 85°C	3K
A81X05F4001AQ5A	QFN40L, Pb Free, Tray, -40°C ~ 85°C	490EA
A81X05F4001AH	Die form, -40°C ~ 85°C	100EA

AMICCOM CONFIDENTIAL

28. Package Information

QFN6*6 48L Outline Dimensions

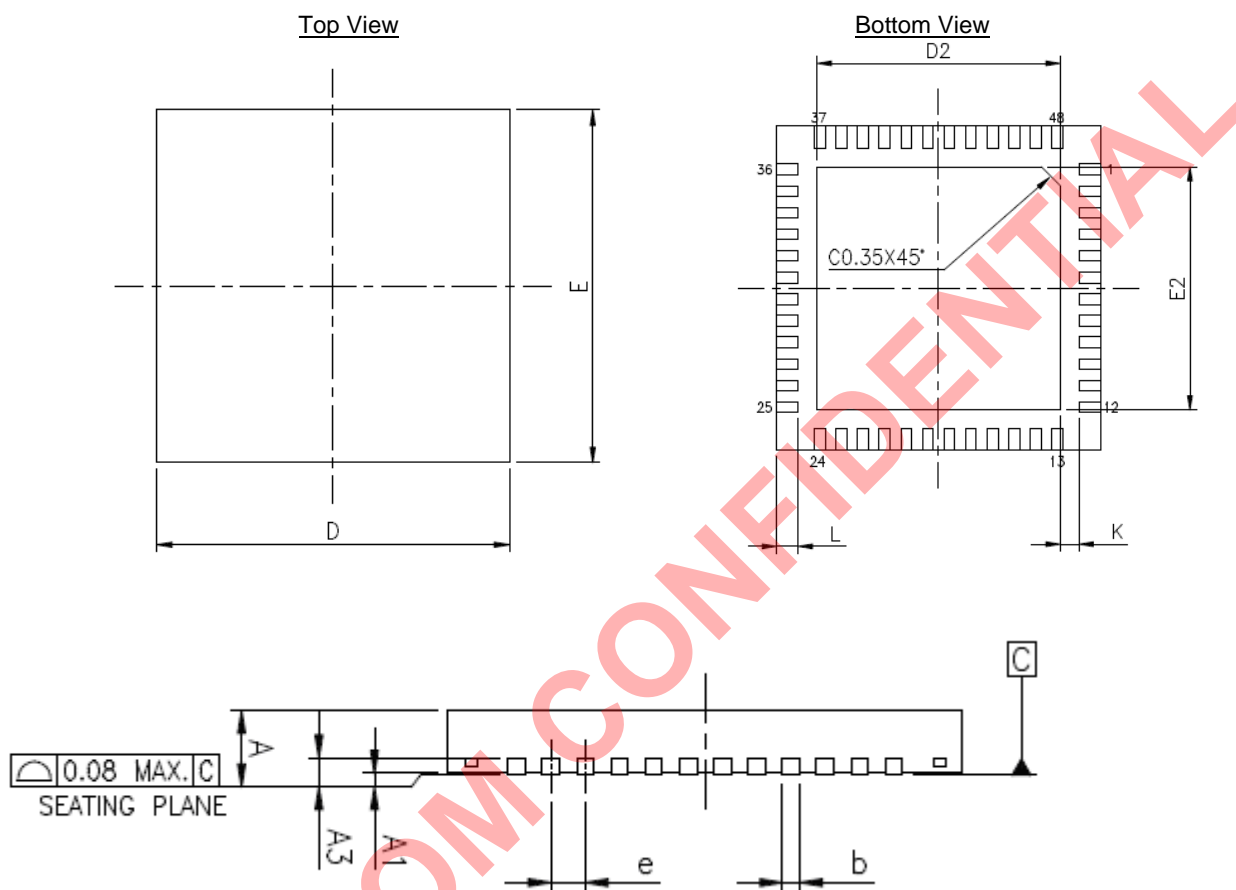

Symbol	Dimensions in inches			Dimensions in mm		
	Min	Nom	Max	Min	Nom	Max
A	0.028	0.030	0.031	0.7	0.75	0.8
A ₁	0	0.001	0.002	0.00	0.02	0.05
A ₃	0.009 REF.			0.23REF.		
b	0.006	0.008	0.010	0.15	0.2	0.25
D	0.240			6.0 BSC		
D ₂	0.146	0.177	0.179	3.70	4.50	4.55
E	0.240			6.0BSC		
E ₂	0.146	0.177	0.179	3.70	4.50	4.55
e	0.016BSC			0.4BSC		
L	0.013	0.016	0.020	0.32	0.4	0.48
k	0.008			0.2		

QFN5*5 32L Outline Dimensions

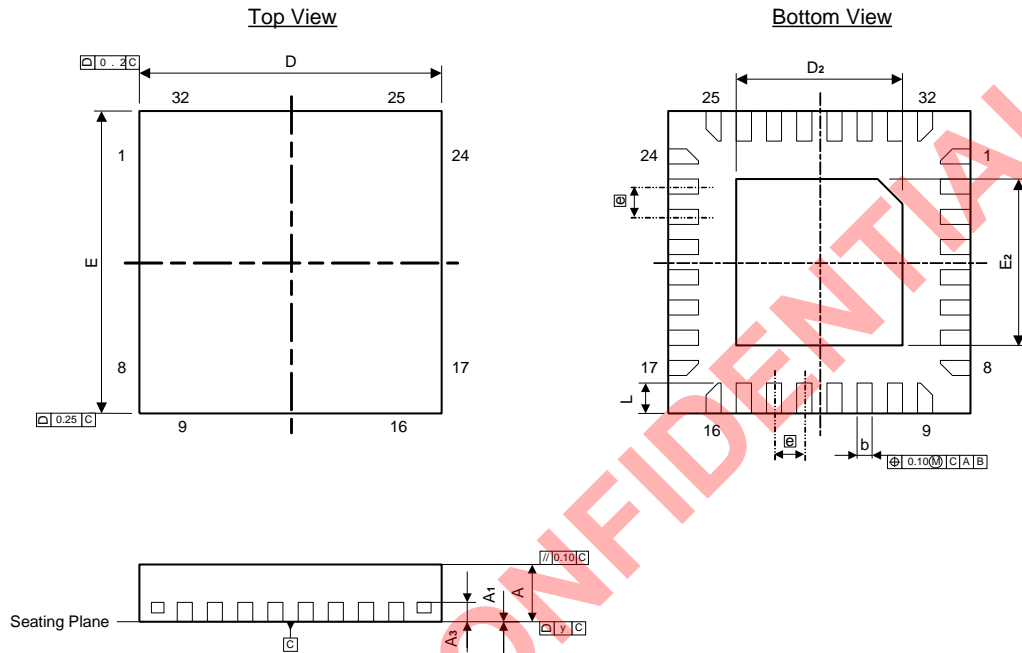

Symbol	Dimensions in inches			Dimensions in mm		
	Min	Nom	Max	Min	Nom	Max
A	0.028	0.030	0.036	0.70	0.75	0.90
A1	0.000	0.001	0.002	0.00	0.02	0.05
A3	0.010 REF			0.20 REF		
b	0.007	0.010	0.012	0.18	0.25	0.30
D	0.193	0.197	0.200	4.90	5.00	5.10
D2	0.049	0.106	0.141	1.25	2.70	3.60
E	0.193	0.197	0.200	4.90	5.00	5.10
E2	0.049	0.106	0.141	1.25	2.70	3.60
e	0.020 BSC			0.50 BSC		
L	0.012	0.016	0.020	0.30	0.40	0.50
y	0 - 0.004			0 - 0.10		

29. Top Marking Information

- Part No. : **A81X05F5009AQ6C**
- Pin Count : **48**
- Package Type : **QFN**
- Dimension : **6*6 mm**
- Mark Method : **Laser Mark**
- Character Type : **Arial**

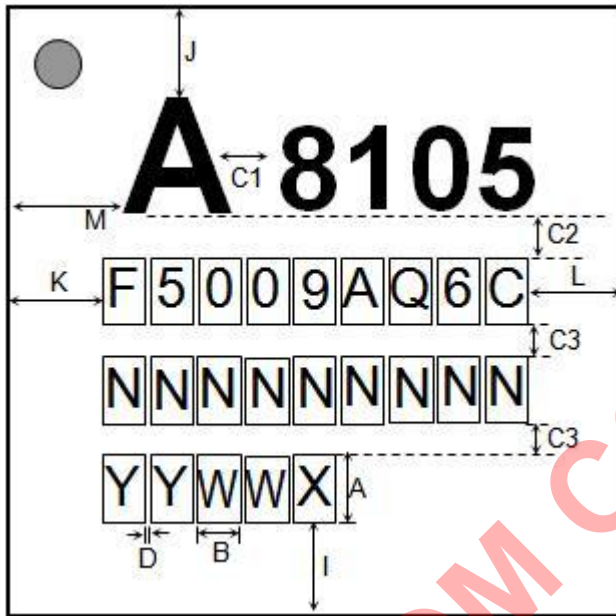

❖ CHARACTER SIZE : (Unit in mm)

A : 0.65
B : 0.45
C1 : 0.3 C2 : 0.4 C3 : 0.3
D : 0.03
M : 1.5

YYWW

: DATECODE

X

: PKG HOUSE ID

NNNNNNNNNN

: LOT NO.
(max. 9 characters)

I=J
K=L

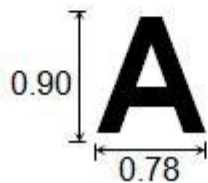

- Part No. : **A81X05F4001AQ5A**
- Pin Count : **40**
- Package Type : **QFN**
- Dimension : **5*5 mm**
- Mark Method : **Laser Mark**
- Character Type : **Arial**

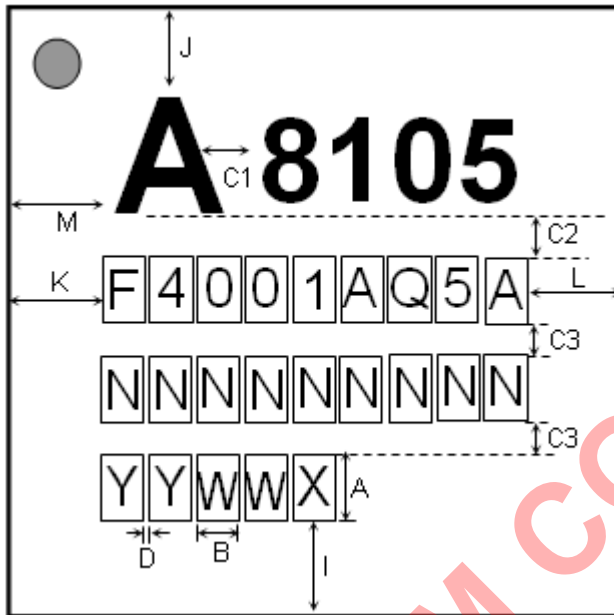

◆ CHARACTER SIZE : (Unit in mm)

A : 0.55
B : 0.36
C1 : 0.25 C2 : 0.3 C3 : 0.2
D : 0.03
M : 1.5

YYWW

: DATECODE

X

: PKG HOUSE ID

NNNNNNNNNN

: LOT NO.
(max. 9 characters)

I=J
K=L

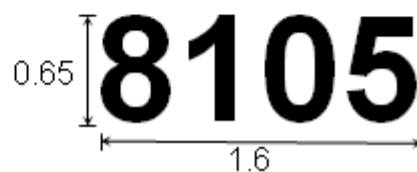
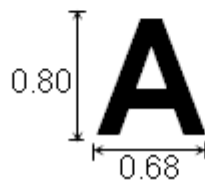

- Part No. : **A81X05F5001AQ5A**
- Pin Count : **40**
- Package Type : **QFN**
- Dimension : **5*5 mm**
- Mark Method : **Laser Mark**
- Character Type : **Arial**

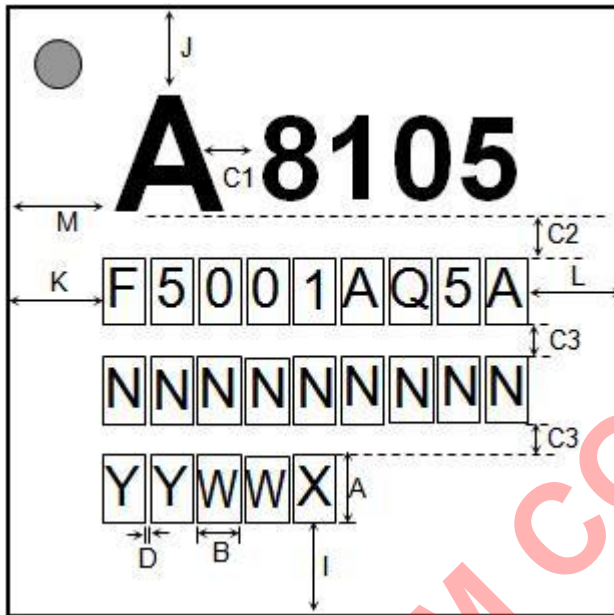

◆ CHARACTER SIZE : (Unit in mm)

A : 0.55
B : 0.36
C1 : 0.25 C2 : 0.3 C3 : 0.2
D : 0.03
M : 1.5

YYWW

: DATECODE

X

: PKG HOUSE ID

NNNNNNNNNN

: LOT NO.
(max. 9 characters)

I=J
K=L

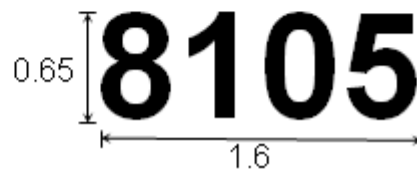
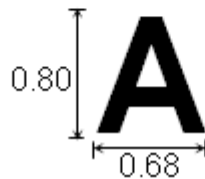

30. Reflow Profile

LEAD FREE (GREEN) PROFILE :

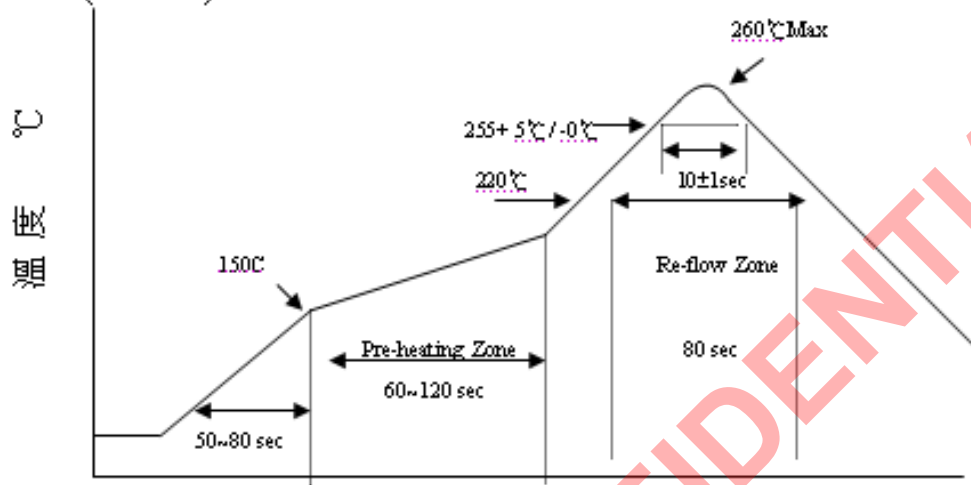

Actual Measurement Graph



31. Tape Reel Information

Cover / Carrier Tape Dimension

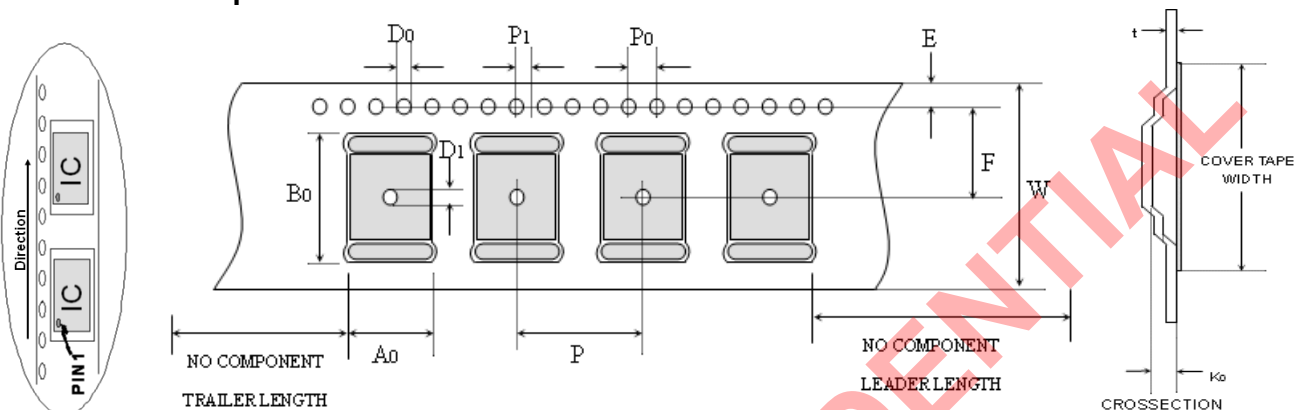

Unit: mm

TYPE	P	A0	B0	P0	P1	D0	D1	E	F	W	K0	t	Cover tape width
QFN 3*3	8±0.1	3.2 5±0.1	3.25 ±0.1	4±0.2	2±0.1	1.5±0.1	1.5	1.75 ±0.1	5.5 ±0.05	12±0.3	1.25 ±0.1	0.3 ±0.05	9.3±0.1
QFN 4*4	8±0.1	4.35 ±0.1	4.35 ±0.1	4±0.2	2±0.1	1.5±0.1	1.5	1.75 ±0.1	5.5 ±0.05	12±0.3	1.2 5±0.1	0.3 ±0.05	9.3±0.1
QFN 5*5	8±0.1	5.25 ±0.1	5.25 ±0.1	4±0.2	2±0.1	1.5±0.1	1.5	1.75 ±0.1	5.5 ±0.05	12±0.3	1.25 ±0.1	0.3 ±0.05	9.3±0.1
QFN 6*6	12±0.1	6.3±0.1	6.3±0.1	4±0.2	2±0.1	1.5±0.1	1.5±0.5	1.75 ±0.1	7.5 ±0.1	16±0.3	1.15 ±0.2	0.3 ±0.05	13.3± 0.1

REEL DIMENSIONS

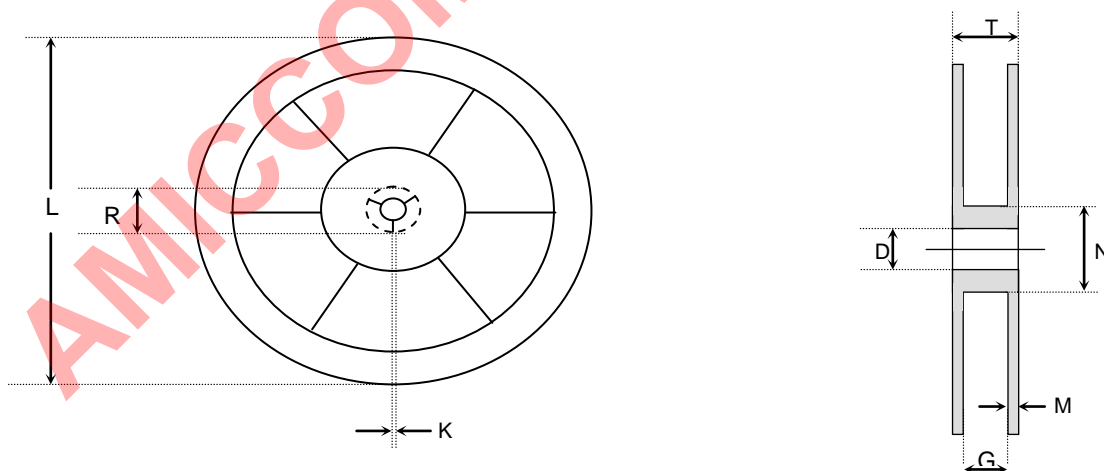

Unit: mm

TYPE	G	N	M	D	K	L	R
QFN3*3/4*4/5*5	12.9±0.5	102 REF±2.0	2.3±0.2	13.15±0.35	2.0±0.5	330±3.0	19.6±2.9
QFN6*6	17±0.5	102 REF±2.0	2.3±0.2	13.15±0.35	2.0±0.5	330±3.0	19.6±2.9

32. Product Status

Data Sheet Identification	Product Status	Definition
Objective	Planned or Under Development	This data sheet contains the design specifications for product development. Specifications may change in any manner without notice.
Preliminary	Engineering Samples and First Production	This data sheet contains preliminary data, and supplementary data will be published at a later date. AMICCOM reserves the right to make changes at any time without notice in order to improve design and supply the best possible product.
No Identification	Noted Full Production	This data sheet contains the final specifications. AMICCOM reserves the right to make changes at any time without notice in order to improve design and supply the best possible product.
Obsolete	Not In Production	This data sheet contains specifications on a product that has been discontinued by AMICCOM. The data sheet is printed for reference information only.

RF ICs AMICCOM



Headquarter

A3, 1F, No.1, Li-Hsin 1st Rd., Hsinchu Science Park,
Hsinchu, Taiwan 30078
Tel: 886-3-5785818

Shenzhen Office

Rm., 2003, DongFeng Building, No. 2010,
Shennan Zhonglu Rd., Futian Dist., Shenzhen, China
Post code: 518031

Web Site

<http://www.amiccom.com.tw>

