

CJT1117B-XXX

FEATURES

- Low Dropout Voltage: 1.15V(typ.) at 1A Output Current
- Trimmed Current Limit
- On-Chip Thermal Shutdown
- Three-Terminal Adjustable or Fixed 1.25V, 1.8V, 2.5V, 3.3V, 5V
- Operation Junction Temperature: -40°C to 125°C

GENERAL DESCRIPTION

The CJT1117B-XXX is a series of low dropout three-terminal regulators with a dropout of 1.15V(typ.) at 1A output current.

The CJT1117B-XXX series provides current limiting and thermal shutdown. Its circuit includes a trimmed bandgap reference to assure output voltage accuracy to be within 1.5%. Current limit is trimmed to ensure specified output current and controlled short-circuit current. On-chip thermal shutdown provides protection against any combination of overload and ambient temperature that would create excessive junction temperature.

The CJT1117B-XXX has an adjustable version, that can provide the output voltage from 1.25V to 5V with only 2 external resistors.

APPLICATIONS

- PC Motherboard
- LCD Monitor
- Graphic Card
- DVD-Video Player
- NIC/Switch
- Telecom Modem
- ADSL Modem
- Printer and Other Peripheral Equipment

MARKING

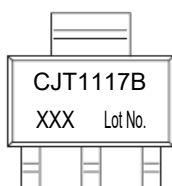

CJT1117B = Device code

XXX: output voltage

SOT -223

1. ADJ/GND
2. OUTPUT
3. IN

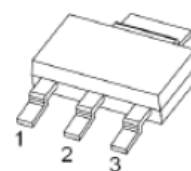

MAXIMUM RATINGS

ORDERING INFORMATION

Package	Operating Junction Temperature Range	Part NO.
SOT-223	-40 to 125°C	CJT1117B-ADJ
		CJT1117B-1.8
		CJT1117B-2.5
		CJT1117B-3.3
		CJT1117B-5.0

ABSOLUTE MAXIMUM RATINGS ($T_a=25^\circ\text{C}$ unless otherwise noted)

Parameter	Symbol	Value	Unit
Input Voltage	V_i	20	V
Thermal Resistance from Junction to Ambient	$R_{\theta JA}$	100	$^\circ\text{C}/\text{W}$
Junction Temperature	T_j	150	$^\circ\text{C}$
Storage Temperature	T_{stg}	-55~+150	$^\circ\text{C}$
Lead Temperature (Soldering, 10s)	T_L	260	$^\circ\text{C}$
ESD Voltage (Machine Model)	V_{ESD}	400	V

Note: Stresses greater than those listed under "Absolute Maximum Ratings" may cause permanent damage to the device. These are stress ratings only, and functional of the device at these or any other conditions beyond those indicated under "Recommended Operating Conditions" is not implied. Exposure to "Absolute Maximum Ratings" for extended periods may affect device reliability.

RECOMMENDED OPERATING CONDITIONS

Parameter	Symbol	Value	Unit
Input Voltage	V_i	15	V
Operating Junction Temperature	T_j	-40~+125	$^\circ\text{C}$

ELECTRICAL CHARACTERISTICS

$V_{IN} \leq 10V$, $T_J = 25^\circ C$ unless otherwise specified.

Parameter	Symbol	Part NO.	Test conditions	Min	Typ	Max	Unit
Reference Voltage	V_{IROC}	CJT1117B-ADJ	$I_{OUT} = 10mA$, $V_{IN} = 3.23V$	1.231	1.250	1.269	V
			$10mA \leq I_{OUT} \leq 1A$, $2.75V \leq V_{IN} - V_{OUT} \leq 13.25V$	1.225	1.250	1.275	
Output Voltage	V_O	CJT1117B-1.8	$I_{OUT} = 10mA$, $V_{IN} = 3.8V$	1.773	1.8	1.827	V
			$10mA \leq I_{OUT} \leq 1A$, $3.3V \leq V_{IN} \leq 12V$	1.764	1.8	1.836	
		CJT1117B-2.5	$I_{OUT} = 10mA$, $V_{IN} = 4.5V$	2.463	2.5	2.538	
			$10mA \leq I_{OUT} \leq 1A$, $4V \leq V_{IN} \leq 12V$	2.450	2.5	2.550	
		CJT1117B-3.3	$I_{OUT} = 10mA$, $V_{IN} = 5.3V$	3.251	3.3	3.350	
			$10mA \leq I_{OUT} \leq 1A$, $4.8V \leq V_{IN} \leq 12V$	3.234	3.3	3.366	
		CJT1117B-5.0	$I_{OUT} = 10mA$, $V_{IN} = 7.0V$	4.925	5.0	5.075	
			$10mA \leq I_{OUT} \leq 1A$, $6.5V \leq V_{IN} \leq 12V$	4.9	5.0	5.1	
Line Regulation	LNR	CJT1117B-ADJ	$I_{OUT} = 10mA$, $1.5V \leq V_{IN} - V_{OUT} \leq 12V$			0.2	%
		CJT1117B-1.8	$I_{OUT} = 10mA$, $1.5V \leq V_{IN} - V_{OUT} \leq 10.2V$			7	mV
		CJT1117B-2.5	$I_{OUT} = 10mA$, $1.5V \leq V_{IN} - V_{OUT} \leq 9.5V$			7	
		CJT1117B-3.3	$I_{OUT} = 10mA$, $1.5V \leq V_{IN} - V_{OUT} \leq 8.7V$			7	
		CJT1117B-5.0	$I_{OUT} = 10mA$, $1.5V \leq V_{IN} - V_{OUT} \leq 7V$			10	
Load Regulation	LDR	CJT1117B-ADJ	$V_{IN} - V_{OUT} = 1.5V$, $10mA \leq I_{OUT} \leq 1A$			0.4	%
		CJT1117B-1.8				7.2	mV
		CJT1117B-2.5				10	
		CJT1117B-3.3				13.2	
		CJT1117B-5.0				20	
Dropout Voltage	V_D		$\Delta V_{REF} = 1\%$, $I_{OUT} = 1.0A$			1.3	V
Adjust Pin Current					60	120	μA
Minimum Load Current	I_L		$1.5V \leq V_{IN} - V_{OUT} \leq 12V$ (ADJ only)		1.7	5	μA
Quiescent Current	I_q		$V_{IN} = V_{OUT} + 1.25V$ (ADJ except)			10	mA
Ripple Rejection	RR		$f = 120Hz$, $C_{OUT} = 22\mu F$ Tantalum, $V_{IN} - V_{OUT} = 3V$, $I_{OUT} = 1A$	60	75		dB
Temperature Stability					0.5		%
Long-Term Stability			$T_A = 125^\circ C$, 1000hrs		0.3		%
RMS Output Noise (% of VOUT)			$T_A = 25^\circ C$, $10Hz \leq f \leq 10kHz$		0.003		%
Thermal Shutdown Hysteresis					25		$^\circ C$

FUNCTIONAL BLOCK DIAGRAM

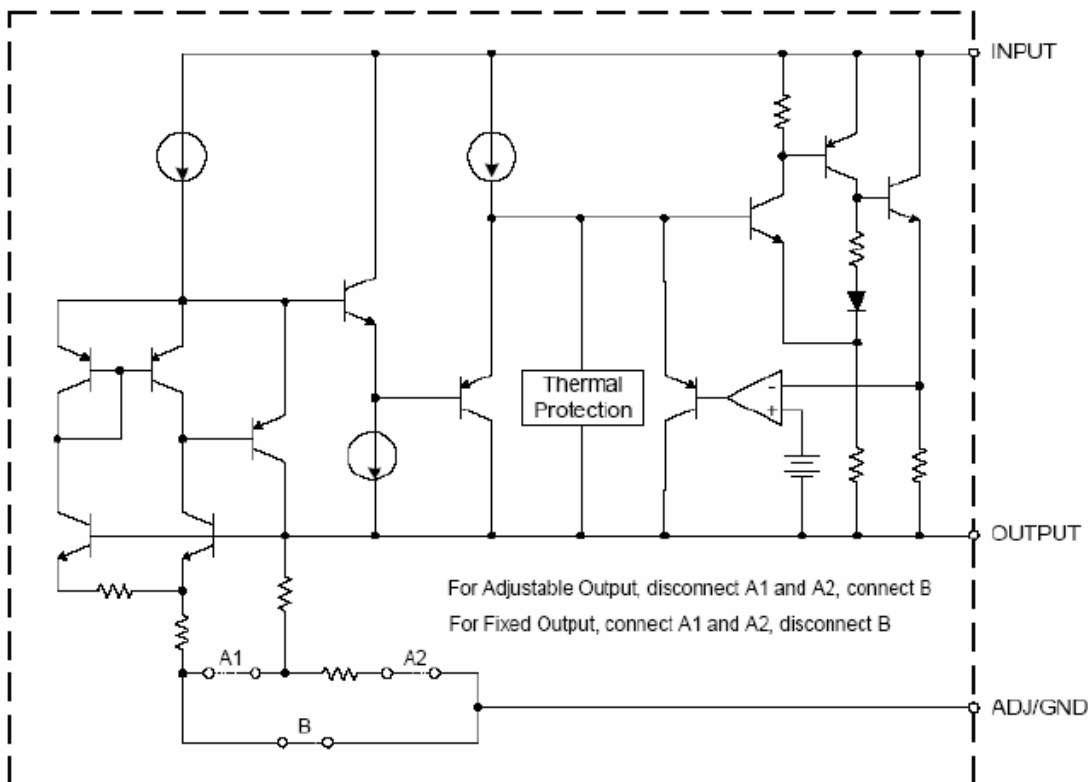

TYPICAL APPLICATION CIRCUIT

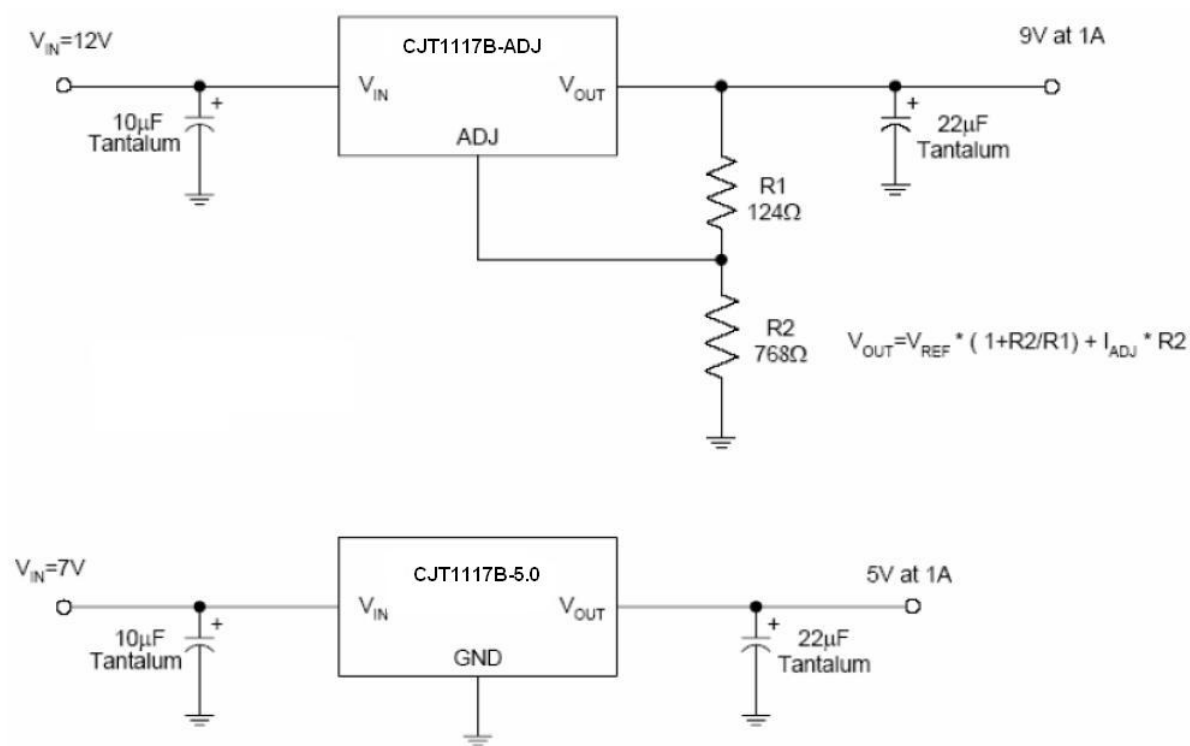

Typical Characteristics

Dropout Voltage vs. Output Current

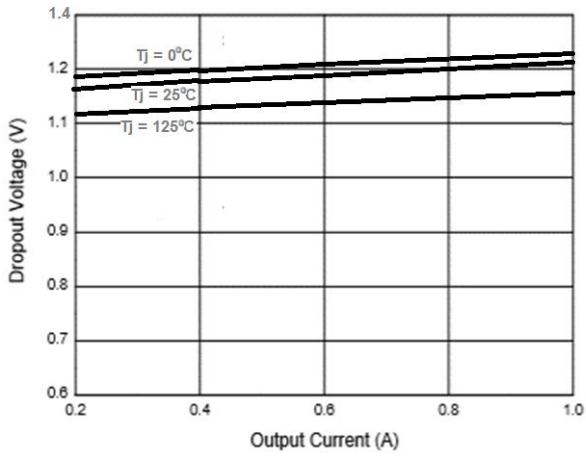

Dropout Voltage vs. Junction Temperature

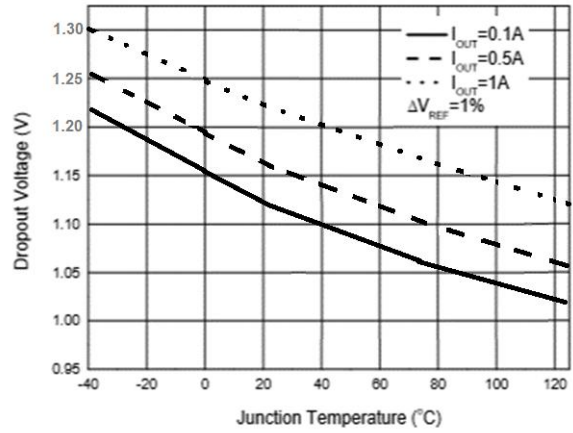

Load Regulation vs. Junction Temperature

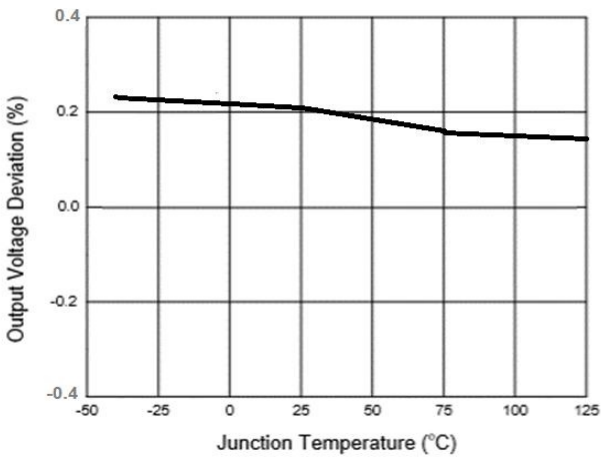

Reference Voltage vs. Junction Temperature

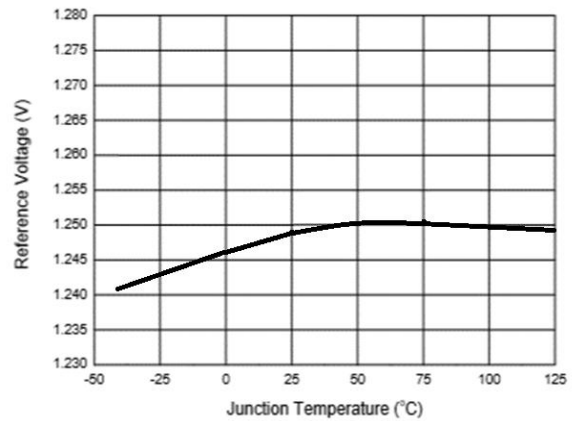

Output Voltage vs. Junction Temperature

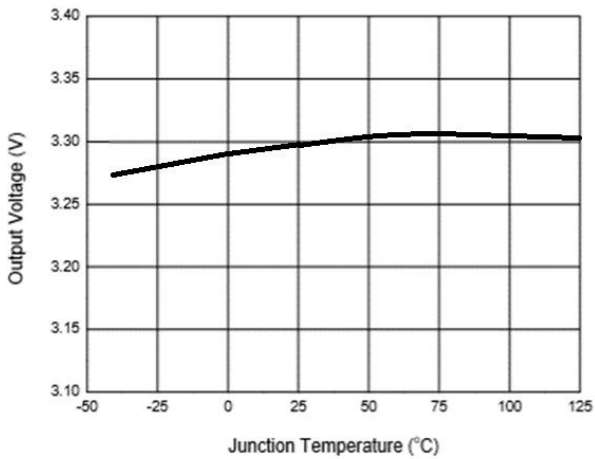

Minimum Load Current vs. Junction Temperature

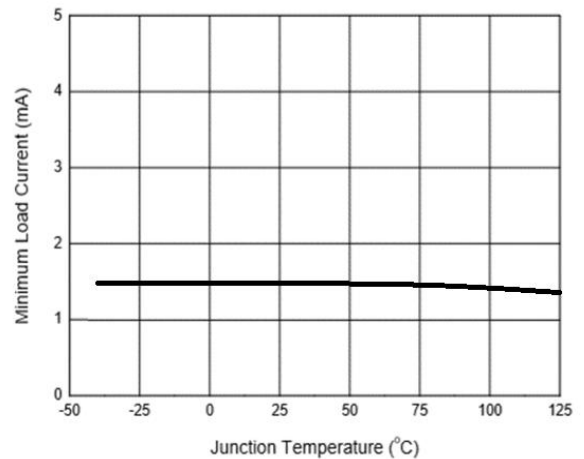

Typical Characteristics

Adjust Pin Current vs. Junction Temperature

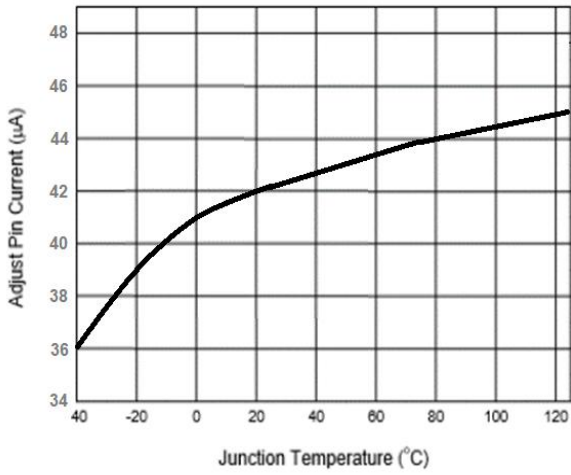

Short-circuit Current vs. Junction Temperature

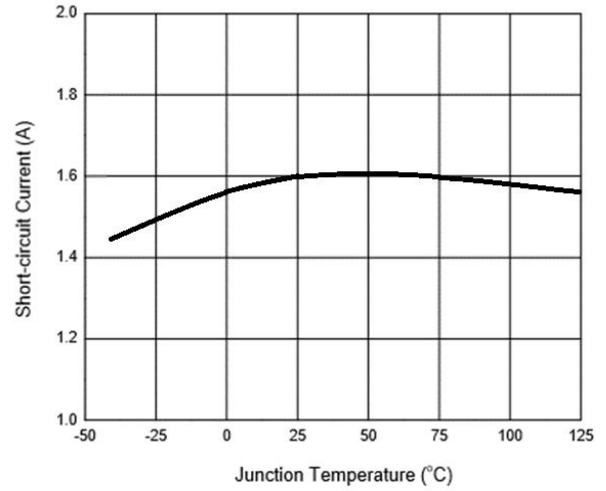

PSRR Vs. Frequency

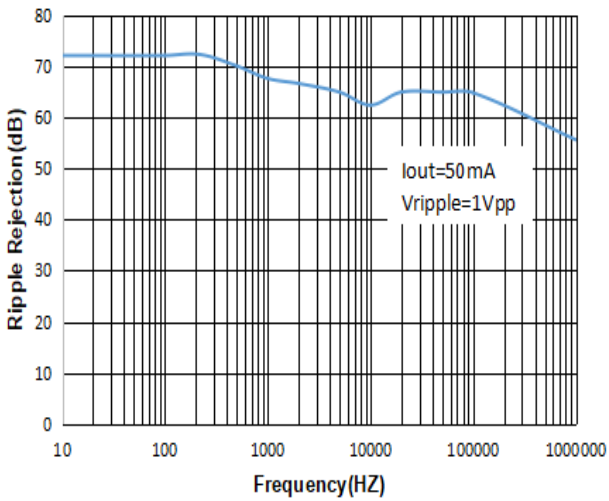

SOT-223 Package Outline Dimensions

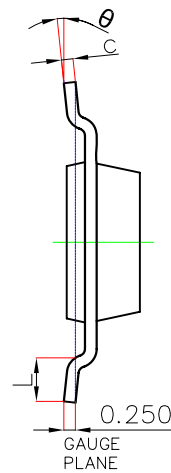
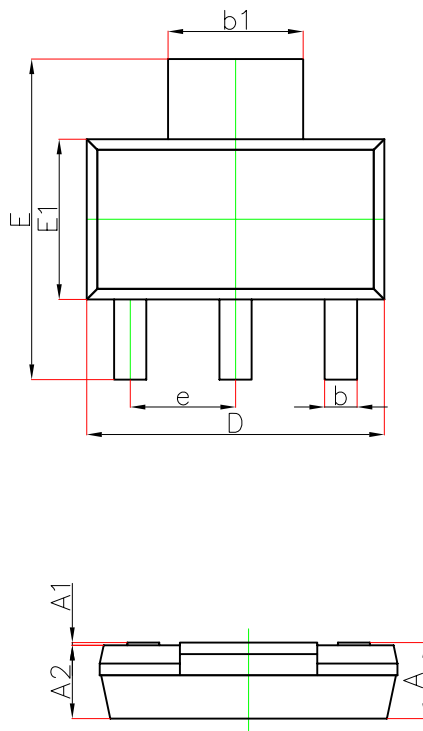

Symbol	Dimensions In Millimeters		Dimensions In Inches	
	Min.	Max.	Min.	Max.
A	—	1.800	—	0.071
A1	0.020	0.100	0.001	0.004
A2	1.500	1.700	0.059	0.067
b	0.660	0.840	0.026	0.033
b_1	2.900	3.100	0.114	0.122
c	0.230	0.350	0.009	0.014
D	6.300	6.700	0.248	0.264
E	6.700	7.300	0.264	0.287
E_1	3.300	3.700	0.130	0.146
e	2.300(BSC)		0.091(BSC)	
L	0.750	—	0.030	—
θ	0°	10°	0°	10°

SOT-223 Suggested Pad Layout

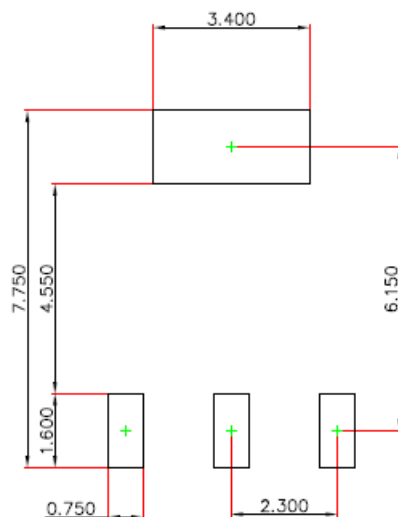

Note:

1. Controlling dimension: in millimeters.
2. General tolerance: ± 0.050 mm.
3. The pad layout is for reference purposes only.

NOTICE

JSCJ reserves the right to make modifications, enhancements, improvements, corrections or other changes without further notice to any product herein. JSCJ does not assume any liability arising out of the application or use of any product described herein.

SOT-223 Tape and Reel

SOT-223 Embossed Carrier Tape

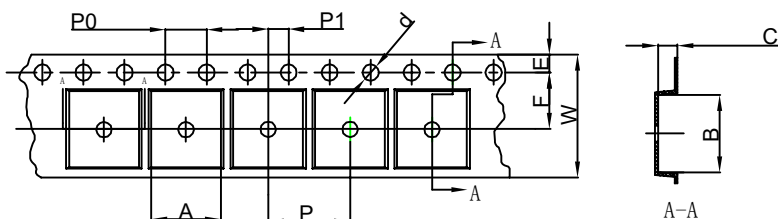

Packaging Description:

SOT-223 parts are shipped in tape. The carrier tape is made from a dissipative (carbon filled) polycarbonate resin. The cover tape is a multilayer film (Heat Activated Adhesive in nature) primarily composed of polyester film, adhesive layer, sealant, and anti-static sprayed agent. These reeled parts in standard option are shipped with 2,500 units per 13" or 33.0cm diameter reel. The reels are clear in color and is made of polystyrene plastic (anti-static coated).

Dimensions are in millimeter										
Pkg type	A	B	C	d	E	F	P0	P	P1	W
SOT-223	6.765	7.335	1.88	Ø1.50	1.75	5.50	4.00	8.00	2.00	12.00

SOT-223 Tape Leader and Trailer

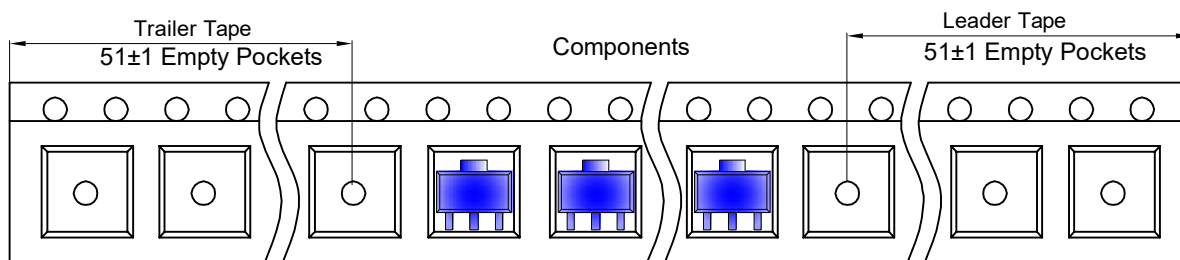

SOT-223 Reel

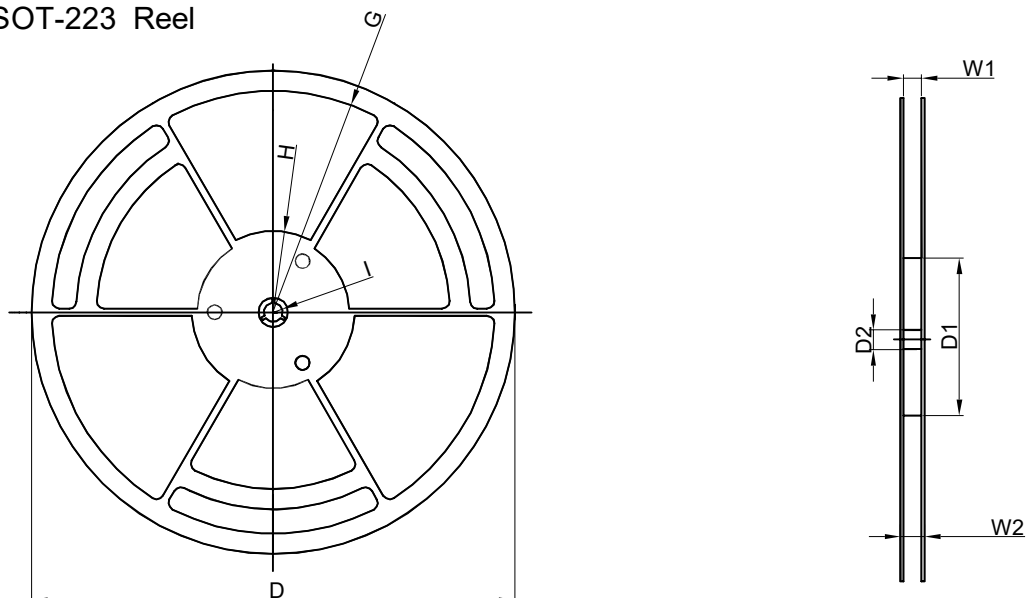

Dimensions are in millimeter								
Reel Option	D	D1	D2	G	H	I	W1	W2
13" Dia	Ø330.00	100.00	13.00	R151.00	R56.00	R6.50	12.40	17.60

REEL	Reel Size	Box	Box Size(mm)	Carton	Carton Size(mm)	G.W.(kg)
2,500 pcs	13 inch	2,500 pcs	336×336×48	20,000 pcs	445×355×365	