

Ultralow Noise Microphone with Top Port and Analog Output

DESCRIPTION

The ZTS6216 is a high quality, low cost, low power analog output Top-ported omni-directional MEMS microphone. ZTS6216 consists of a MEMS microphone element and an preamplifier. ZTS6216 has a high SNR and flat wideband frequency response, resulting in natural sound with high intelligibility. Extra EMI filter for RF noise attenuation is built inside. Due to the built-in filter, ZTS6216 shows high immunity to EMI.

The ZTS6216 is available in a thin 2.75mm × 1.85mm × 1.00mm surface-mount package. It is reflow solder compatible with no sensitivity degradation. The ZTS6216 is halide Halogen and Lead free.

APPLICATIONS

- Mobile telephones
- Smart phones
- PDAs
- Digital video cameras
- Portable media devices with audio input

ORDERING INFORMATION

PART	RoHS	Ship, Quantity
ZTS6216	Yes	Tape and Reel, 5.2K

FEATURES

- 2.75mm X 1.85mm X 1.00mm surface-mounted small-sized package
- Flat Frequency Response SNR of 65dBA
- Sensitivity of -38dBV/Pa
- Low Current
- Max RF protection
- Ultra-Stable Performance
- Standard SMD Reflow
- Omni-directional

Pins Configuration and Description

Bottom view

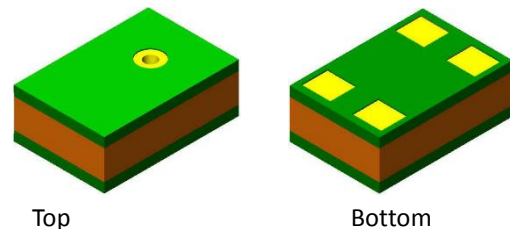
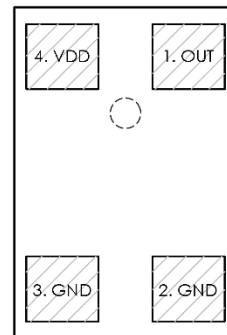

Typical Applications

The ZTS6216 output can be connected to a codec microphone input or to a high input impedance gain stage. A dc-blocking capacitor is required at the output of the microphone.

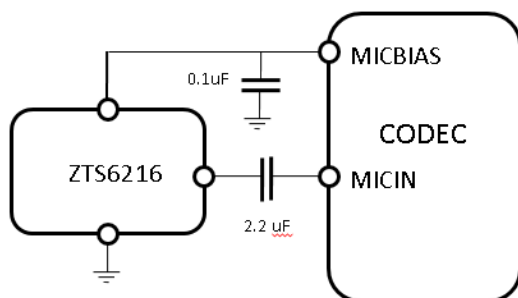

Connect to Audio OPAM

Note:

All Ground pins must be connected to ground.

Capacitors near the microphone should not contain Class 2 dielectrics.

Absolute Maximum Ratings

V_{DD} to Ground-0.5V to +5V
 OUT to Ground.....-0.3V to V_{DD}+0.3V
 Input Current to Any Pin.....± 5 mA
 Temperature Range.....-40°C to +125°C

CAUTION: Stresses above those listed in “Absolute Maximum Ratings” may cause permanent damage to the device. This is a stress only rating and operation of the device at these or any other conditions above those indicated in the operational sections of this specification is not implied.

Functional Block Diagram

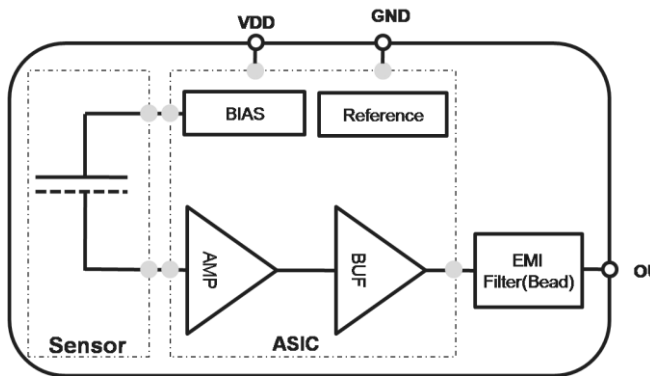

Electro-Static Discharge Sensitivity



This integrated circuit can be damaged by ESD. It is recommended that all integrated circuits be handled with proper precautions. Failure to observe proper handling and installation procedures can cause damage. ESD damage can range from subtle performance degradation to complete device failure.

Pins Description

Pin	Symbol	Description
1	OUT	Analog output signal.
2	GND	Ground
3	GND	Ground
4.	VDD	Power Supply.

Specifications

(TEST CONDITIONS: 23 ±2°C, 55±20% R.H., $V_{DD}(\min) \leq V_{DD} \leq V_{DD}(\max)$, no load, unless otherwise indicated.)

PARAMETER	Symbol	CONDITIONS	MIN	TYP	MAX	UNIT
Supply Voltage ¹	V_{DD}		1.5	-	3.6	V
Supply Current ^{1,2}	I_{DD}		-	120	150	μA
Sensitivity ¹	S	94 dB SPL @ 1 kHz	-39	-38	-37	dBV/Pa
Signal to Noise Ratio	SNR	94 dB SPL @ 1 kHz, A-weighted	63	65	-	dB(A)
Total Harmonic Distortion	THD	94 dB SPL @ 1 kHz	-	0.2	1	%
Acoustic Over load Point	AOP	10% THD @ 1 kHz		125	-	dB SPL
Power Supply Rejection Ratio	PSRR	200mVpp sinewave @ 1 kHz, $V_{DD} = 1.8V$	-	65	-	dB
Power Supply Rejection	PSR	100 mVpp square wave @ 217 Hz, $V_{DD} = 1.8V$, A-weighted	-	-90	-	dBV(A)
DC Output		$V_{DD} = 1.5V$	-	0.9	-	V
Output Impedance	Z_{OUT}	@ 1 kHz	-	100	-	
Directivity			Omni-directional			
Polarity		Increasing sound pressure	Increasing output pressure			

Note:

¹ 100% tested

² Maximum specifications are measured at maximum V_{DD} . Typical specifications are measured at $V_{DD} = 1.8V$.

Typical Performance Characteristics

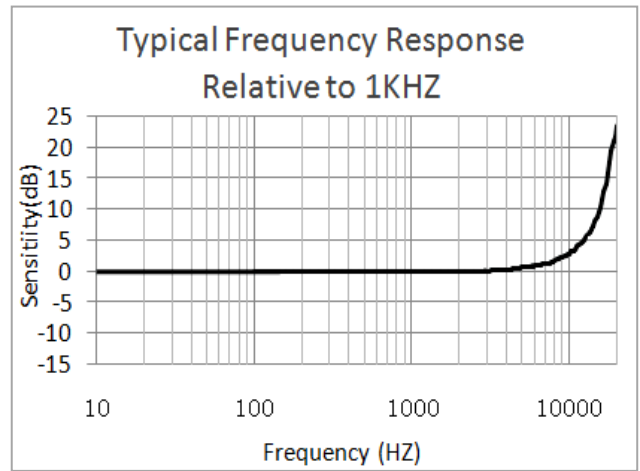
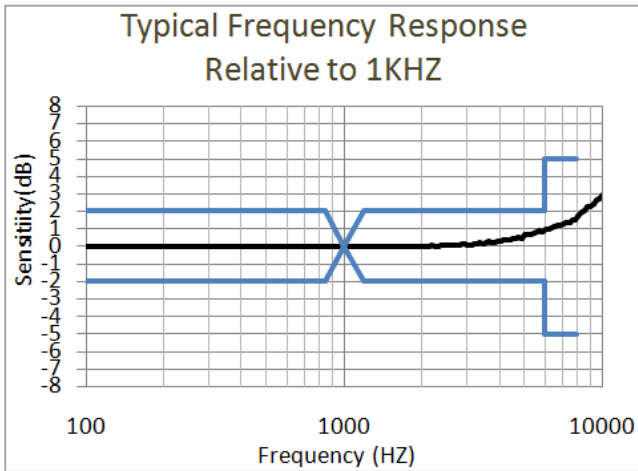

Reliability Specifications

The microphone sensitivity after stress must deviate by no more than $\pm 3\text{dB}$ from the initial value.

1. Heat Test, Operational	Temperature: $125\pm 3^{\circ}\text{C}$ Duration: 1000 hours Voltage: Applied
2. Cold Test, Operational	Temperature: $-40\pm 3^{\circ}\text{C}$ Duration: 1000 hours Voltage: Applied
3. Heat Test, Non-Operational	Temperature: $125\pm 3^{\circ}\text{C}$ Duration: 1000 hours Voltage: Not Applied
4. Cold Test, Non-Operational	Temperature: $-40\pm 3^{\circ}\text{C}$ Duration: 1000 hours Voltage: Not Applied
5. Thermal Shock Test, Non-Operational	Temperature: $-40\pm 3^{\circ}\text{C}$ and $125\pm 3^{\circ}\text{C}$ Duration: 30 minutes each, during 5 minutes ramp, 256 cycles Voltage: Not applied
6. Temperature humidity storage	Temperature: $85\pm 3^{\circ}\text{C}$ Humidity: $85\pm 3\% \text{RH}$ Duration: 1000 hours
	Temperature: $65\pm 3^{\circ}\text{C}$ Humidity: $95\pm 3\% \text{RH}$ Duration: 168 hours
7. Free Fall Test 1.5m	Placed inside test fixture and dropped on concrete from height 1.5m. 4 times by each surface and corner
8. Vibration	4 cycles of 20 to 2000 Hz sinusoidal sweep with 20G peak acceleration lasting 12 minutes in X, Y, and Z directions
9. Mechanical Shock	5 pulses of 10000g in each of the $\pm X$, $\pm Y$, and $\pm Z$ directions
10. Electrostatic Discharge Test	Capacitance: 150pF Resistance: 330Ω Duration: 10 times Air Discharge: Level 4 ($\pm 15\text{kV}$) Direct contact discharge: Level 4 ($\pm 8\text{kV}$)
11. Human Body Mode	± 2000 Volt
12. Charged-Device Model	± 250 Volt
13. Reflow	5 reflow cycles with peak temperature of 260°C
14. Solderability	$245\pm 5^{\circ}\text{C}$, 5sec, 95% Tin on pad surface
15. Tumble test	300 tumbles from a height of 1m onto a steel base.
16. HAST	Temperature: $130\pm 3^{\circ}\text{C}$ Humidity: $85\pm 3\% \text{RH}$ Duration: 96 hours Voltage: Applied
17. Air Blow	0.45MPa, distance 3cm, time 10s

MECHANICAL SPECIFICATIONS

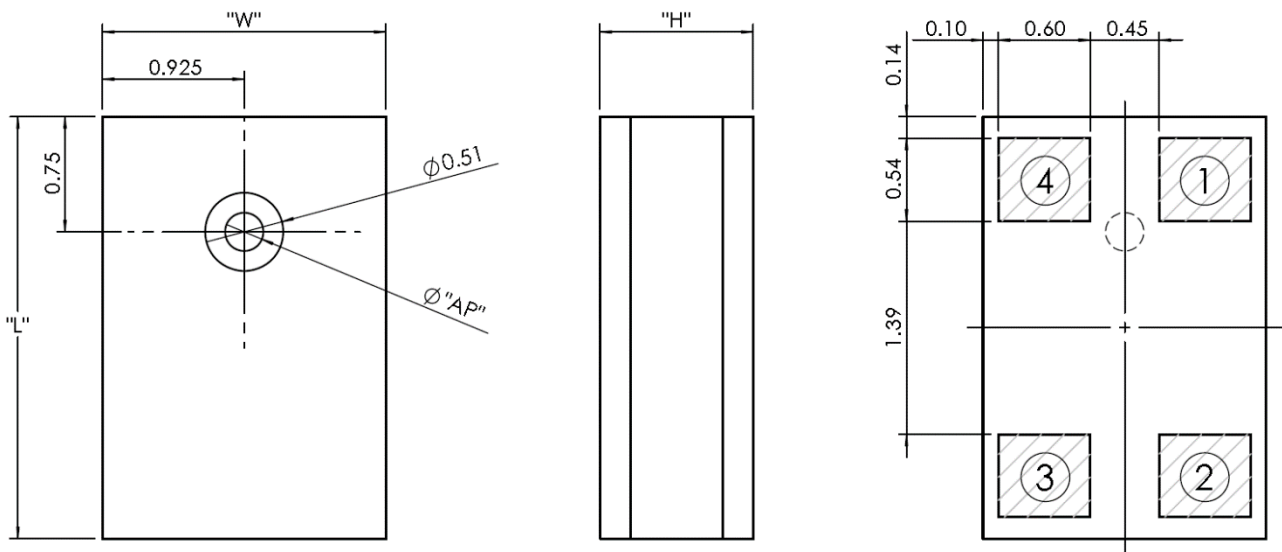

Item	Dimension	Tolerance
Length (L)	2.75	±0.100
Width (W)	1.85	±0.100
Height (H)	1.00	±0.100
Acoustic Port (AP)	Ø0.50	±0.050

RECOMMENDED CUSTOMER LAND PATTERN

The recommended PCB land pattern for the ZTS6117 should have a 1:1 ratio to the solder pads on the microphone package. Care should be taken to avoid applying solder paste to the sound hole in PCB. The dimensions of suggested solder paste pattern refer to the land pattern **which should be shrunk by 0.025 per side**.

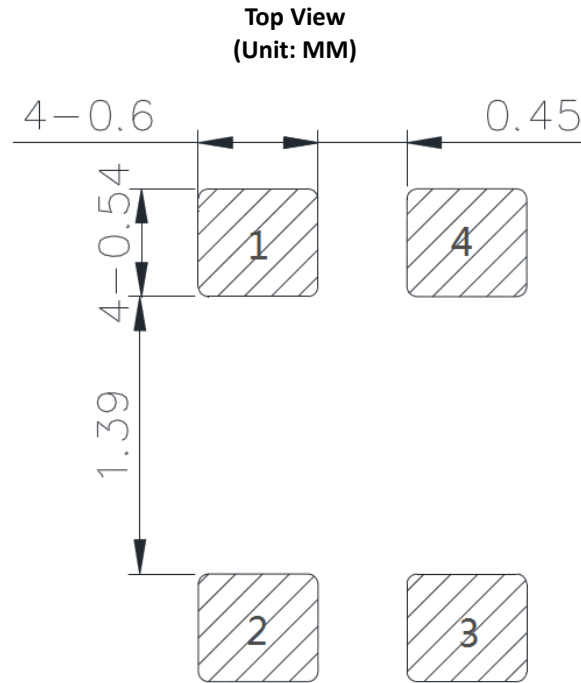

SOLDER FLOW PROFILE

The reflow profile specified in this section describes expected maximum heat exposure of components during the reflow process of NMP product PWBs. Temperature is measured on top of component. All components have to tolerate at least this profile five times (5x) without affecting electrical performance, mechanical performance or reliability.

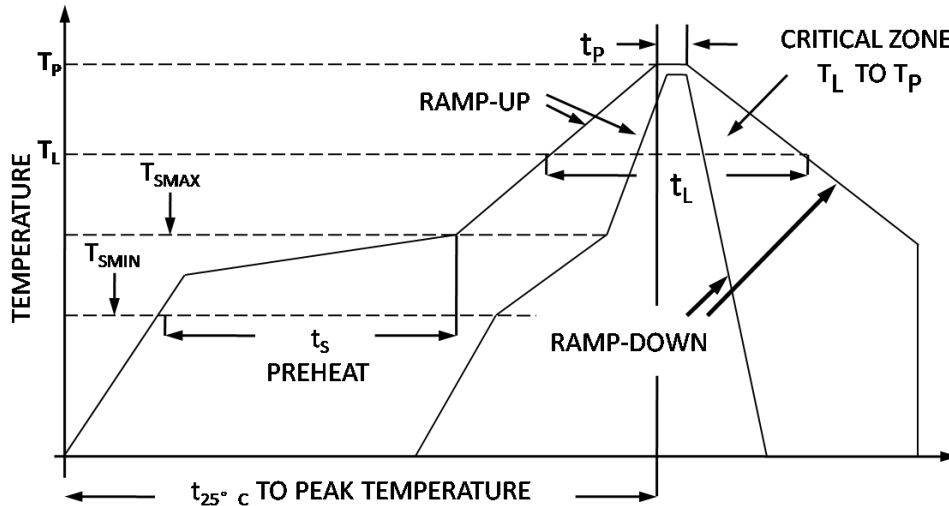

Pb-free and Sn63/Pb37 reflow profile requirements for soldering heat resistance:

Parameter	Reference	Pb-Free	Sn63/Pb37
Average Ramp Rate	T _L to T _P	1.25°C/sec max	1.25 °C /sec max
Prehear	Minimum Temperature	100°C	100 °C
	Maximum Temperature	200°C	150 °C
	Time	T _S MIN to T _S MAX	60sec to 120sec
Ramp-Up Rate	T _S MAX to T _L	1.25°C/sec	1.25 °C /sec
Time Maintained Above Liquidous	t _L	60sec to 150sec	60sec to 150sec
Liquidous Temperature	T _L	217°C	183 °C
Peak Temperature	T _P	260°C +0°C/-5°C	215 °C +3 °C /-3 °C
Time Within +5°C of Actual Peak Temperature	t _p	20 sec to 30 sec	20 sec to 30 sec
Ramp-Down Rate	T _{peak}	6°C/sec max	6 °C /sec max
Time +25°C (t _{250c}) to Peak Temperature		8 min max	6 min max

PACKAGING

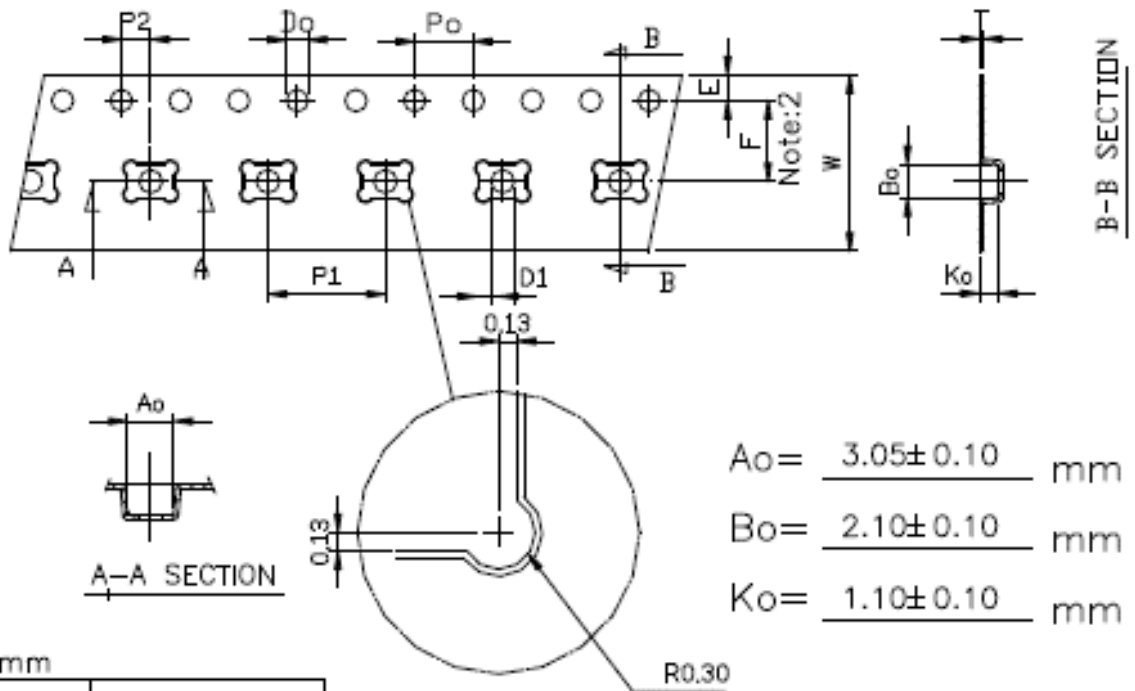

Unit: mm

Symbol	Spec.
Po	4.0±0.10
P1	8.0±0.10
P2	2.0±0.10
Do	1.50 ^{+0.1} ₋₀
D1	1.50 ^{+0.1} ₋₀
E	1.75±0.10
F	5.50±0.10
10Po	40.0±0.10
W	12.0±0.30
T	0.30±0.05

Notice:

1. 10 Sprocket hole pitch cumulative tolerance is ±0.1mm
2. Pocket position relative to sprocket hole measured as true position of pocket not pocket hole.
3. Ao & Bo measured on a place 0.3mm above the bottom of the pocket to top surface of the carrier.
4. Ko measured from a plane on the inside bottom of the pocket to the top surface of the carrier.
5. Carrier camber shall be not than 1mm per 100mm through a length of 250mm.

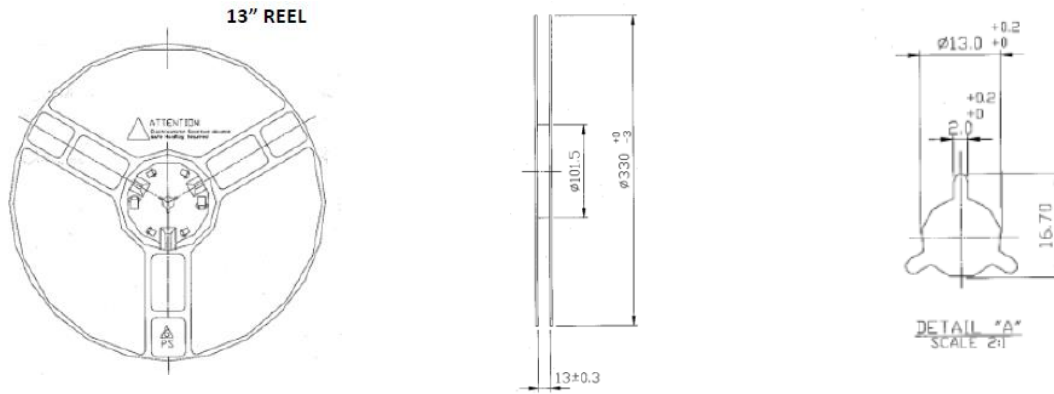

Part NO.	Reel Diameter	Quantity Per Reel	Quantity Per Inner Box	Quantity Per Outer Box
ZTS6216	13"	5,200	5,200	46,800

Dimensions for Inner Box

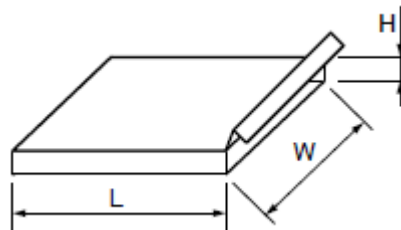

Unit : mm

L	W	H
335	339	45

Dimensions for Outer Box

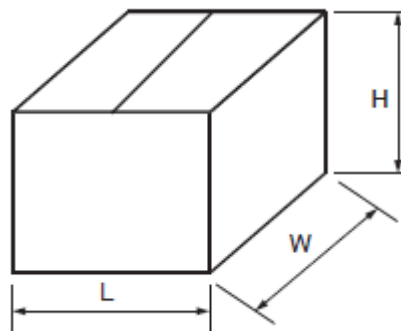

Unit : mm

L	W	H
445	360	372