



TAI-SAW TECHNOLOGY CO., LTD.

No. 3, Industrial 2nd Rd., Ping-Chen Industrial District,
Taoyuan, 324, Taiwan, R.O.C.

TEL: 886-3-4690038 FAX: 886-3-4697532

E-mail: tstsales@mail.taisaw.com Web: www.taisaw.com

Product Specifications Approval Sheet

Product Description: Crystal Unit SMD 2.0x1.6 16.0MHz

TST Part No.: TZ2486A

Customer Part No.: _____

Customer signature required
Company: _____
Division: _____
Approved by : _____
Date: _____

Checked by: _____ Derick Lin *Derick*

Approved by: _____ Kelly Huang *Kelly Huang*

Date: _____ 06/16/2015

1. Customer signed back is required before TST can proceed with sample build and receive orders.
2. Orders received without customer signed back will be regarded as agreement on the specifications.
3. Any specifications changes must be approved upon by both parties and a new revision of specifications shall be released to reflect the changes.



TAI-SAW TECHNOLOGY CO., LTD.

Crystal Unit SMD 2.0x1.6 16.0MHz

MODEL NO.: TZ2486A

REV. NO.: 3

Revise:

Rev.	Rev. Page	Rev. Account	Date	Ref. No.	Revised by
1	N/A	Initial release	12/6/2012'	N/A	Stephen Wei
2	4	Update base higher	02/23/2013	ECN-201300064	Stephen Wei
3	3	Change ESR Spec	06/16/15'	ECN-201500165	Derick Lin
3	7	Revise RA table	06/16/15'	WI-76Q01	Derick Lin



TAI-SAW TECHNOLOGY CO., LTD.

Crystal Unit SMD 2.0x1.6 16.0MHz

MODEL NO.: TZ2486A

REV. NO.: 3

Features:

- Surface Mount Hermetic Package
- Excellent Reliability Performance
- Good Frequency Perturbation and Stability over temperature
- Ultra Miniature Package

RoHS Compliant
Lead free
Lead-free soldering

Description and Applications:

Surface mount 2.0mmx1.6mm crystal unit for use in wireless communications devices, especially for a need of ultra miniature package for mobility.

Electrical Specifications:

TZ2486A	Specification
Nominal Frequency	16.000000 MHz
Mode of Oscillation	Fundamental
Storage Temperature Range	-40°C to +90°C
Operating Temperature Range	-20°C to +80°C
Frequency Stability over Operating Temperature Range	+/-20 ppm (referred to the value at 25°C)
Frequency Make Tolerance (FL)	+/-10 ppm @ 25°C +/- 3°C
Equivalent Series Resistance (ESR)	150 Ω max
Nominal Drive Level	10uW typical and 100uW max
Shunt Capacitance (Co)	5.0 pF max
Load Capacitance (CL)	8 pF
Aging	+/-1ppm/year
Insulation Resistance	500 MΩ min./DC 100V
Marking	Laser Marking
Unit Weight	5.7mg+/-0.5mg

Mechanical Dimensions (mm):

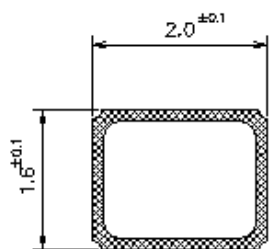

Internal Connections
(Top View)

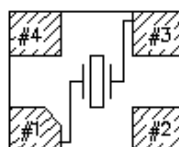

[NOTE] #2, #4 is connected with a metal cover

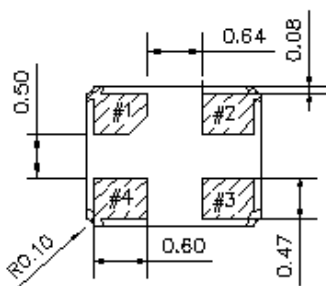

	Pin connection
#1 Pin	IN/OUT
#2 Pin	NC
#3 Pin	IN/OUT
#4 Pin	GND

Recommended Land Pattern: (unit: mm)

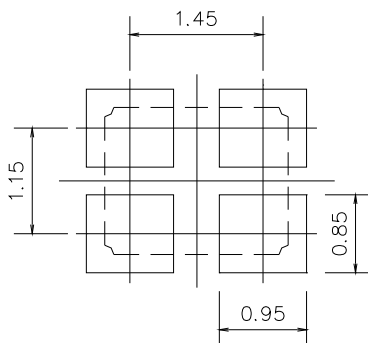

Recommended Land Pattern

Marking:

Line 1: XX; Frequency (16)

Line 2: T; Traceable Code + D; date Code of Year/Month

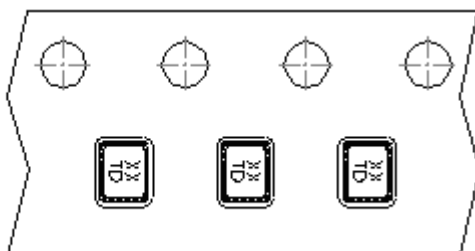
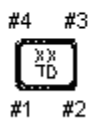

Date Code Table: Year/Month

Year/Month	1	2	3	4	5	6	7	8	9	10	11	12
2009	n	p	q	r	s	t	u	v	w	x	y	z
2010	A	B	C	D	E	F	G	H	J	K	L	M
2011	N	P	Q	R	S	T	U	V	W	X	Y	Z
2012	a	b	c	d	e	f	g	h	i	j	k	m
2013	n	p	q	r	s	t	u	v	w	x	y	z
2014	A	B	C	D	E	F	G	H	J	K	L	M
2015	N	P	Q	R	S	T	U	V	W	X	Y	Z
2016	a	b	c	d	e	f	g	h	i	j	k	m
2017	n	p	q	r	s	t	u	v	w	x	y	z
2018	A	B	C	D	E	F	G	H	J	K	L	M
2019	N	P	Q	R	S	T	U	V	W	X	Y	Z
2020	a	b	c	d	e	f	g	h	i	j	k	m
2021	n	p	q	r	s	t	u	v	w	x	y	z

Reel Dimensions (mm):

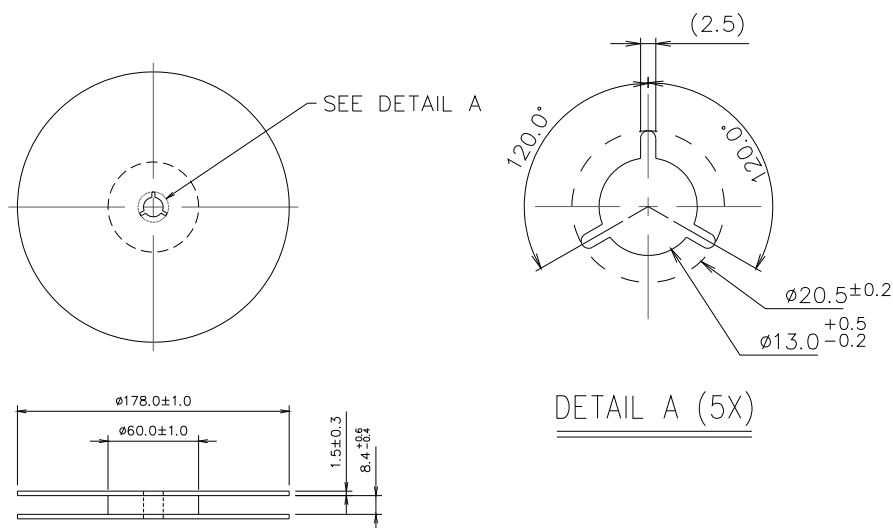

Tape Dimensions (mm):

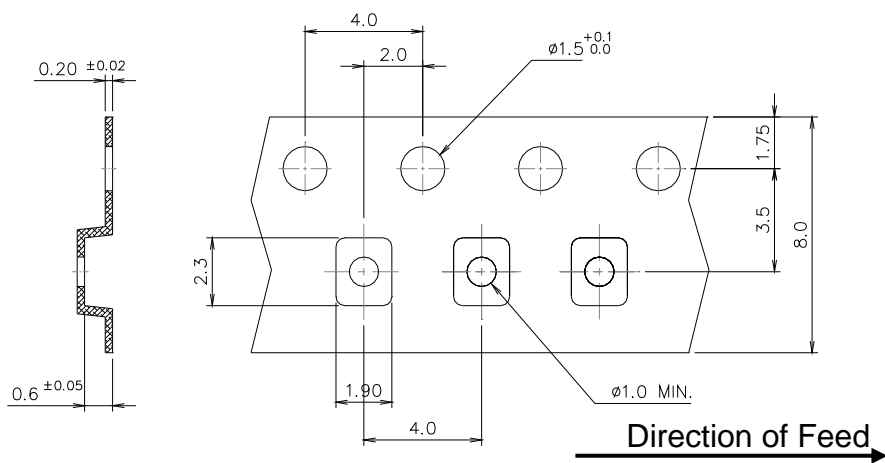

[NOTE]:

1. Unless otherwise specified tolerance on dimension +/-0.1 mm.
2. Material: conductive polystyrene with color black.
3. 10 pitch cumulative tolerance +/-0.2 mm.

Packing Quantity/Packing:

3K pcs maximum per reel

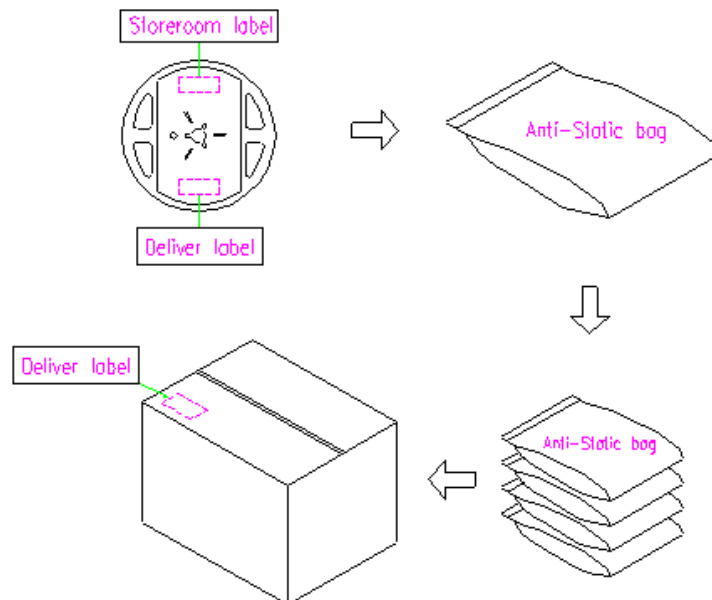

Reflow Profile:

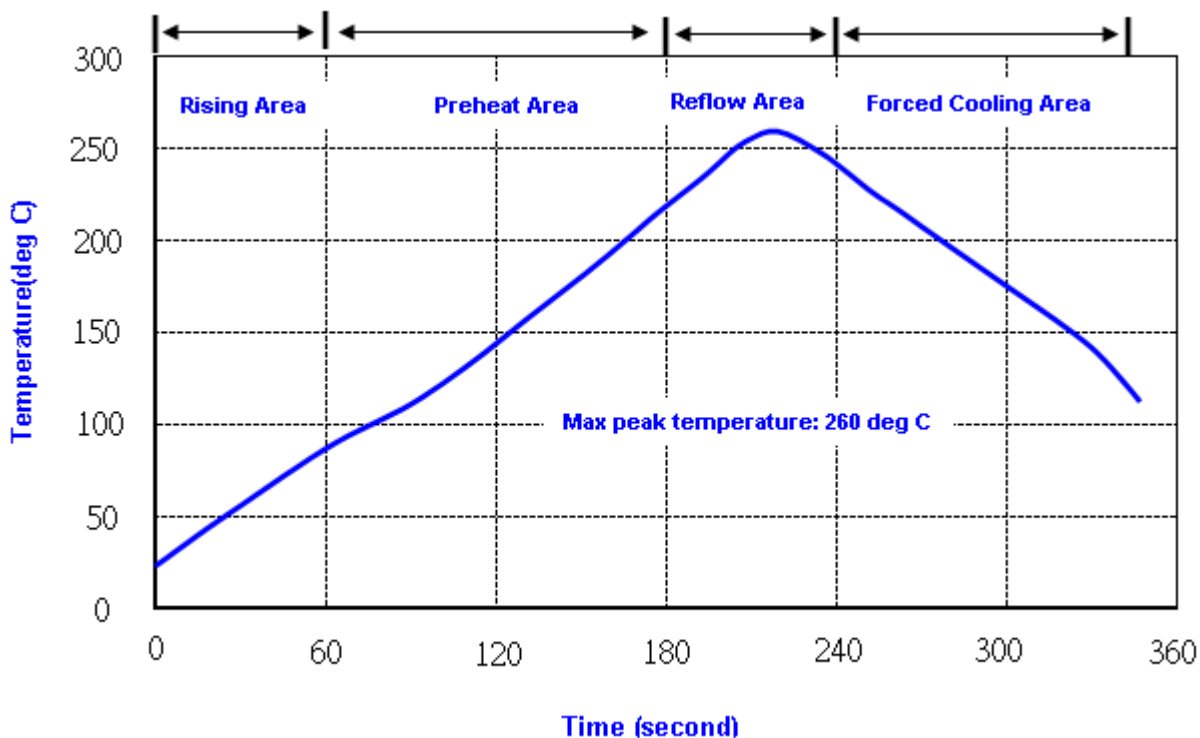

Note: 1. Max peak temperature: 260+/-5 deg C; Time: 10+/-2 sec

2. Temperature: 217+/-5 deg C; Time: 90~100 sec

Reliability Specifications

Test name	Test process / method
Mechanical characteristics	
resistance to Soldering heat (IR reflow)	Temp./ Duration : 265°C /10sec x2 times Total time : 4min.(IR-reflow)
Vibration	Total peak amplitude : 1.5mm Vibration frequency : 10 to 2000 Hz Sweep period : 20 minute Vibration directions : 3 mutually perpendicular Duration : 2 hr / direc.
Mechanical Shock	directions : 3 impacts per axis Acceleration : 6000g's, +20/-0 % Duration : 0.3 ms (total 18 shocks) Waveform : Half-sine
Solderability	Solder Temperature:265±5°C Duration time: 5±0.5 seconds.
Environmental characteristics	
Thermal Shock	Heat cycle conditions -55 °C (30min) ↔ 125 °C (30min) * cycle time : 10 times
Humidity test	Temperature : 85 ± 2 °C Relative humidity : 85% Duration : 96 hours
Dry heat (Aging test)	Temperature : 125 ± 2 °C Duration : 168 hours
Cold resistance (Low Temp Storage)	Temperature : -40 ± 3 °C Duration : 96 hours
PCT test	Pressure: 2.06kg/cm ² (2.03*10 ⁵ pa) Temperature : 121 ± 2 °C Relative humidity : 100% Duration : 24 hours