



# APPROVAL SHEET

Approval Specification	Customer's Approval Certificate
TO:	Checked & Approved by:
Part No.:	Date:
Customer's Part No.:	Please return this copy as a certification of your approval

## BEIJING ZHONGXUN SIFANG SCIENCE & TECHNOLOGY CO.,LTD.

Tel: +86-010-58937383  
Fax: +86-010-58937263  
E-mail: [zxsf\\_sales@163.com](mailto:zxsf_sales@163.com)  
QQ: 3037058772  
Website: <http://www.bjzxsf.net> <http://www.sfsaw.com>  
Add: No 201, Block A. Building 3. Yongjie Beilu  
Yongfeng high-tech industrial base  
Haidian District Beijing city



Part No.	:	SFR304D
Pages	:	7
Date	:	2015/11/17
Revision	:	1.0

Prepared by:	
Checked by:	
Approved by:	



Features

- 1-port Resonator
- Ceramic Package for **Surface Mounted Technology (SMT)**
- **RoHS** compatible
- Package size 5.00x5.00x1.50mm<sup>3</sup>
- Package Code QCC8C
- **Electrostatic Sensitive Device(ESD)**

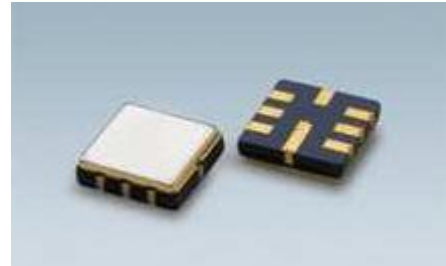

Application

Typical Low-Power Transmitter Application

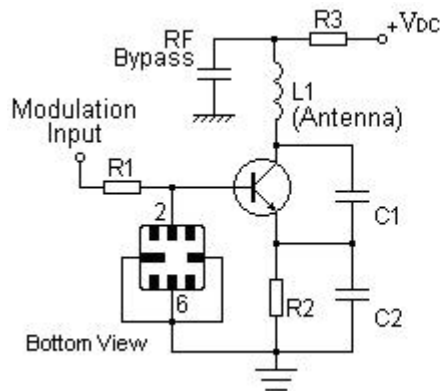

Typical Local Oscillator Application

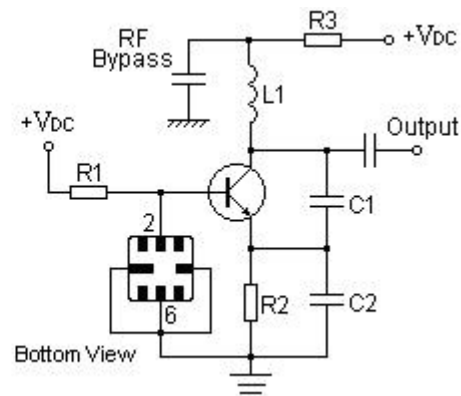

Package Dimensions (QCC8C)

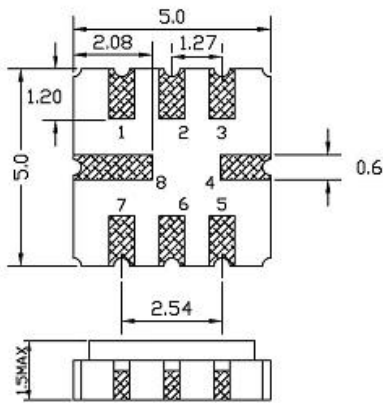

Pin Configuration

2	Input/ Output
6	Output/ Input
1,3,5,7	To be Grounded
4,8	Case Ground

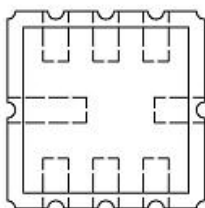

## Marking Description

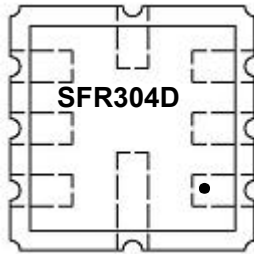

●	Pin 4
R	SAW Resonator
340.3	Part Number

## Test Circuit

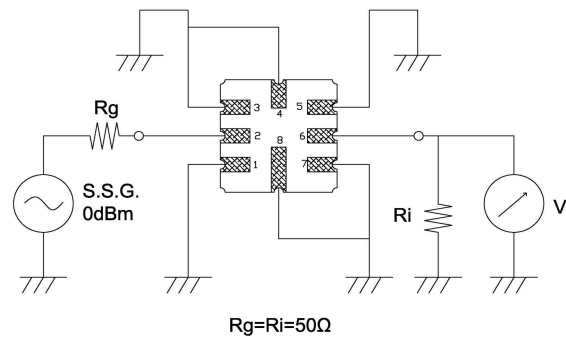

## Equivalent LC Model

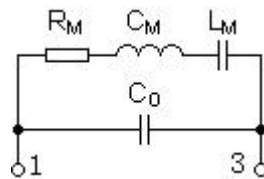

## Performance

## Maximum Rating

Item		Value	Unit
DC Voltage	$V_{DC}$	$\pm 30$	V
Operation Temperature	T	-40 ~ +85	°C
Storage Temperature	$T_{stg}$	-40 ~ +85	°C
RF Power Dissipation	P	15	dBm

### Electronic Characteristics

Test Temperature: 25°C±2°C

Terminating source impedance: 50Ω

Terminating load impedance: 50Ω

Item			Minimum	Typical	Maximum	Unit
Center Frequency	Absolute Frequency	$f_c$		304.30		MHz
	Tolerance from 304.30MHz	$\Delta f_c$		±75		KHz
Insertion Loss(min)		IL		1.1	2.0	dB
Quality Factor	Unloaded Q	$Q_U$		17496		
	50Ω Loaded Q	$Q_L$		1789		
Frequency Aging	Absolute Value during the First Year	$ f_A $		≤10		ppm/yr
DC Insulation Resistance between Any Two Pins			1.0			MΩ
RF Equivalent RLC Model	Motional Resistance	$R_M$		11.3	15.0	Ω
	Motional Inductance	$L_M$		104.3		μH
	Motional Capacitance	$C_M$		2.74		fF
	Static Capacitance	$C_0$	3.62	3.92	4.22	pF

### Frequency Response





**Notes**

1. As a result of the particularity of inner structure of SAW products, it easy to be breakdown by electrostatic, so we should pay attention to **ESD protect** in the test.
2. **Static voltage** between signal load and ground may cause deterioration and destruction of the component. Please avoid static voltage.
3. **Ultrasonic cleaning** may cause deterioration and destruction of the component. Please avoid ultrasonic cleaning.
4. Only leads of component may **be soldered**. Please avoid soldering another part of component.
5. There is a close relationship between the device's performance and **matching network**. The specifications of this device are based on the test circuit shown above. L and C values may change depending on board layout. Values shown are intended as a guide only.