

**WAS4768Q**
**DPDT USB2.0 Hi-Speed (480Mbps) and HiFi Audio Switches with Negative Swing Capability**
[Http://www.willsemi.com](http://www.willsemi.com)
**Descriptions**

The WAS4768Q is a high performance, Double-Pole, Double Throw (DPDT) multiplexer that combines a low-distortion audio and a USB2.0 High-Speed (HS) switch path. This configuration enables audio and USB data to share a common connector port. The architecture is designed to allow audio signals to swing below ground. This means a analog audio over USB-C connector can be used for personal media players and portable peripheral devices.

With Max. 24V high voltage range of USB\_Sel pin, WAS4768Q can be configured for automatic USB communication with USB\_Sel tie to VBUS directly. The WAS4768Q includes a over voltage protection of D+/R & D-/L pin with 4.75V OVLO threshold to protect internal port. Typical applications involve switching in portables and consumer applications such as mobile phone, tablet, laptop, portable media players.

The WAS4768Q is available in QFN1418-10L package. Standard products are Pb-Free and halogen-Free.

**Applications**

- USB Type C

**Features**

- Single Supply Voltage : 2.5~ 4.5V
- USB\_Sel Pin Voltage : 24V
- D+/R & D-/L Pin OVP Threshold : 4.75V
- Audio Path On-Resistance : 2.5Ω
- THD+N@ 32Ω load & 0.7Vrms : -105dB
- Signal-to-Noise (SNR) Ratio : 115dBA
- USB Path -3dB Bandwidth : 900MHz
- USB Path On-Resistance : 6.5Ω
- Audio Swing Range (R<sub>L</sub> = 1KΩ) : 2.5Vrms
- Built-In shunt function of Audio Paths to Inhibit Audio Pop and Click

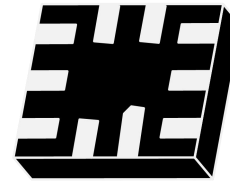
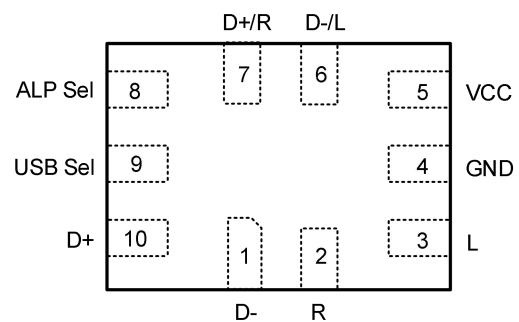
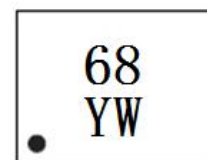
**QFN1418-10L**

**Pin configuration (Top view)**

**Marking**

- 68** = Device code
- Y** = Year code(A~z)
- W** = Week code(A~z)

**Order information**

Device	Package	Shipping
WAS4768Q-10/TR	QFN1418-10L	3000/Reel&Tape

**Pin descriptions**

Pin Number	Symbol	Descriptions
1	D-	USB data (Negative ) input sources
2	R	Audio Right input sources
3	L	Audio Left input sources
4	GND	Ground
5	VCC	Power supply
6	D-/L	USB data (Negative ) and audio Left common connector ports
7	D+/R	USB data (Positive ) and audio Right common connector ports
8	A/LP_Sel	Audio Select Override and Power-Save Mode. This pin can be used to override USB Sel for applications where analog audio is transmitted on the USB D+, D- lines. This same select pin is used to put the WAS4768Q in low-power mode when USB Sel is LOW, not transmitting audio signals or USB data. The WAS4768Q has a weak internal pull-down, setting its default state to LOW and allowing this pin to float when not in use.
9	USB_Sel	USB Path select pin. Can be connected to USB connector VBUS pin for automatic USB detection
10	D+	USB data (Positive ) input sources

**Function descriptions**

A/LP_Sel	USB_Sel	Audio Mode	USB Mode	Remarks
0	0	OFF	OFF	OFF Mode, Both USB and Audio OFF
0	1	OFF	ON	USB Communication
1	X	ON	OFF	Audio Out

**Notes:**

1. Forcing USB Sel HIGH when VBUS is present allows for automatic USB detection.
2. HIGH is the threshold as defined to meet USB2.0 VCC requirements and audio supply threshold in a system (see EC Tables).

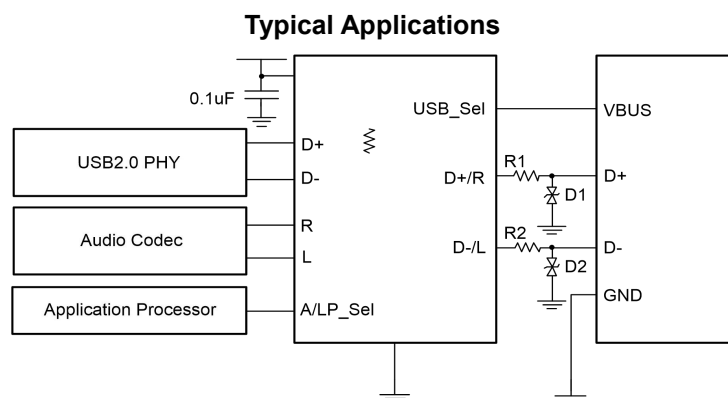
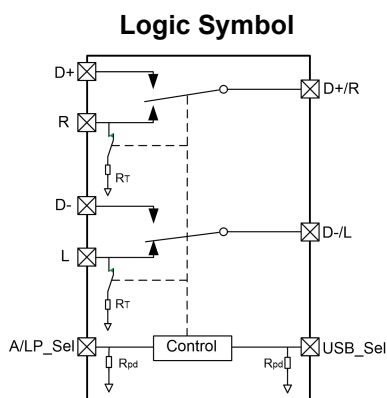
**Logic symbol and typical applications**

**Note:** Recommend R1=R2=3Ω; Recommend D1 and D2 to use ESD63011N  
And place them close to USB Connector

**Absolute maximum ratings**

Parameter	Symbol	Value	Unit
Supply voltage range	$V_{CC}$	-0.3 ~ 6.5	V
USB signal voltage range	$V_{USB}$	-0.3 ~ 4.0	V
Audio signal voltage range	$V_{AUDIO}$	-2.5 ~ $V_{CC}$	V
D-/L;D+/R signal voltage range	$V_{COM}$	-2.5 ~ 7	V
USB_Sel pin voltage range	$V_{USB\_SEL}$	-0.3 ~ 24	V
A/LP_Sel pin voltage range	$V_{A/LP\_SEL}$	-0.3 ~ 6.5	V
Continues output current (USB)	$I_{OUT}$	±100	mA
Continues output current (Audio)	$I_{OUT}$	±200	mA
Junction temperature range	$T_J$	150	°C
Lead temperature range	$T_L$	260	°C
Storage temperature range	$T_{STG}$	-65 ~ +150	°C
Thermal resistance	$R_{\theta JA}$	250	°C/W
ESD protection (HBM)	A/LP, USB_Sel to GND	±8000	V
	$V_{CC}$ to GND	±5000	V
	D+, D- to GND	±8000	V
	D+/R, D-/L to GND	±4000	V
	L,R to GND	±2000	V

**Recommend operating ratings**

Parameter	Symbol	Value	Unit
Supply voltage range	$V_{CC}$	2.5 ~ 4.5	V
USB signal voltage range	$V_{USB}$	0.0 ~ 3.3	V
Audio signal voltage range	$V_{AUDIO}$	-2.5 ~ +2.5	V
USB_Sel pin voltage range	$V_{USB\_SEL}$	-0 ~ 20	V
A/LP_Sel pin voltage range	$V_{A/LP\_SEL}$	-0 ~ 5.5	V
Operating temperature range	$T_{OPR}$	-40 ~ 85	°C

**Note:**

1. “Absolute Maximum Ratings” may cause permanent damage to the device. This is a stress only rating and operation of the device at these or any other conditions beyond those indicated in the operational sections of this specification is not implied.
2. The input and output negative voltage ratings may be exceeded if the input and output diode current ratings are observed.

**Electronics Characteristics (Ta=25°C, Vcc=3.3V, unless otherwise noted)**

Parameter	Symbol	Conditions	Min.	Typ.	Max.	Unit
Control Input Voltage HIGH	V <sub>IH</sub>	2.5V < V <sub>CC</sub> < 3.0V	1.3			V
		3.0V < V <sub>CC</sub> < 3.5V	1.5			V
Control Input Voltage LOW	V <sub>IL</sub>	2.5V < V <sub>CC</sub> < 3.0V			0.3	V
		3.0V < V <sub>CC</sub> < 3.5V			0.5	V
A/LP_Sel Input Leakage Current	I <sub>IN</sub>	0 < V <sub>IS</sub> < V <sub>CC</sub>			2	uA
USB_Sel Input Leakage Current	I <sub>IN</sub>	0 < V <sub>IS</sub> < 20V			2	uA
Off state leakage current	I <sub>OFF</sub>	V <sub>BUS_SEL</sub> = 0 V, 4.2 V; V <sub>D-/L</sub> , V <sub>D+/R</sub> = 0 V, 4.2 V V <sub>D+</sub> , V <sub>D-</sub> = 4.2 V, 0 V or float V <sub>L</sub> , V <sub>R</sub> = float or 4.2 V, 0 V			1	uA
A/LP_Sel and USB_Sel Internal Pull-Down Resistors	R <sub>PD</sub>			4		MΩ
Audio Path Termination Resistors	R <sub>T</sub>			33		Ω
HS USB Switch On Resistance	R <sub>ONUSB</sub>	V <sub>D+/D-</sub> = 0V~0.4V, I <sub>ON</sub> = 10mA		5.5	7	Ω
HS USB Switch Delta R <sub>ON</sub>	ΔR <sub>ONUSB</sub>	V <sub>D+/D-</sub> = 0V~0.4V, I <sub>ON</sub> = 10mA		0.5		Ω
Audio Switch On Resistance	R <sub>ONAudio</sub>	V <sub>L/R</sub> = -2V~+2V, I <sub>ON</sub> = 60mA		2.5	2.7	Ω
Audio Switch Delta R <sub>ON</sub>	ΔR <sub>ONAudio</sub>	V <sub>L/R</sub> = -2V~+2V, I <sub>ON</sub> = 60mA		0.02		Ω
Audio Switch R <sub>ON</sub> Flatness	R <sub>FLATAudio</sub>	V <sub>L/R</sub> = -2V~+2V, I <sub>ON</sub> = 60mA		0.02		Ω
Quiescent Supply Current	I <sub>CC</sub>	OFF Mode		30	50	uA
		USB Mode		75	100	
		Audio Mode		235	260	
Non-Adjacent Channel Crosstalk	Xtalk	Audio Mode f=1KHz R <sub>T</sub> =32Ω		-80		dB
		USB Mode f=240MHz R <sub>T</sub> =50Ω		-35		
Off Isolation	O <sub>IRR</sub>	Audio Mode f=1KHz R <sub>T</sub> =32Ω		-100		dB
		USB Mode f=240MHz R <sub>T</sub> =50Ω		-40		
-3dB Bandwidth (USB Mode)	BW	R <sub>T</sub> =50Ω, C <sub>L</sub> =0pF Signal 0dBm		900		MHz
Total Harmonic Distortion (Audio Mode)	THD	f = 20Hz to 20KHz, R <sub>L</sub> = 32Ω, V <sub>IN</sub> = 0.7V <sub>rms</sub>		-105		dB
		f = 20Hz to 20KHz, R <sub>L</sub> = 1KΩ, V <sub>IN</sub> = 1.5V <sub>rms</sub>		-110		dB
Signal-to-Noise Ratio (Audio Mode)	SNR	f = 20Hz to 20kHz, R <sub>L</sub> = 32Ω, V <sub>IN</sub> = 2V <sub>rms</sub>		-115		dB
D+/R, D-/L On Capacitance	C <sub>ON</sub>	V <sub>Bias</sub> = 0.2V, f = 1MHz		5		pF
USB Path Off Capacitance	C <sub>OFF1</sub>	V <sub>Bias</sub> = 0.2V, f = 1MHz		3		pF
Audio Path Off Capacitance	C <sub>OFF2</sub>	V <sub>Bias</sub> = 0.2V, f = 1MHz		4		pF

**Typical Characteristics (Ta=25°C, VCC=3.3V, unless otherwise noted)**
**0.1Vrms-3Vrms @1KHz, RL>100KΩ**

Audio Precision

10/21/16 15:29:58

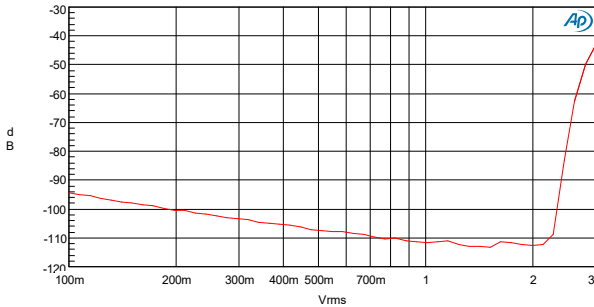

Sweep	Trace	Color	Line Style	Thick	Data	Axis	Comment
1	1	Red	Solid	1	Anlr.TH+N Ratio	Left	

THD+N.at27

**20Hz~20KHz @0.7Vrms, RL>100KΩ**

Audio Precision

10/21/16 15:50:08

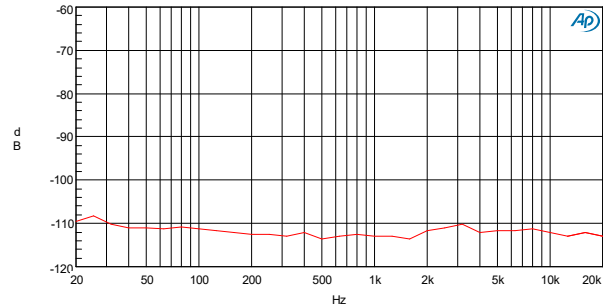

Sweep	Trace	Color	Line Style	Thick	Data	Axis	Comment
1	1	Red	Solid	1	Anlr.TH+N Ratio	Left	

THD+N.at27

**0.1Vrms-3Vrms @1KHz, RL=1KΩ**

Audio Precision

10/21/16 15:32:17

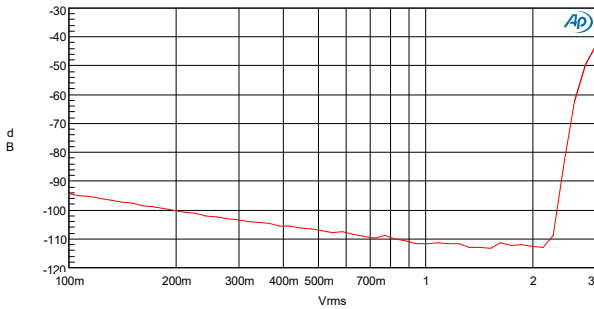

Sweep	Trace	Color	Line Style	Thick	Data	Axis	Comment
1	1	Red	Solid	1	Anlr.TH+N Ratio	Left	

THD+N.at27

**20Hz~20KHz @0.7Vrms, RL=1KΩ**

Audio Precision

10/21/16 15:45:39

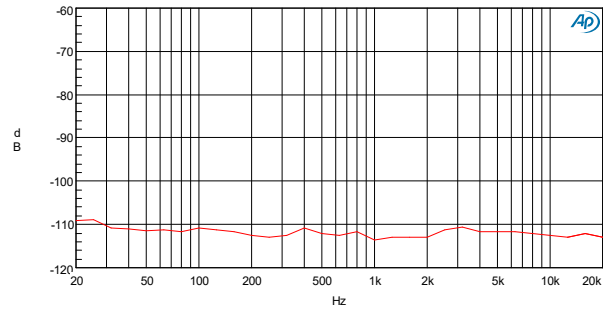

Sweep	Trace	Color	Line Style	Thick	Data	Axis	Comment
1	1	Red	Solid	1	Anlr.TH+N Ratio	Left	

THD+N.at27

**0.1Vrms-3Vrms @1KHz, RL=32Ω**

Audio Precision

10/21/16 15:48:44

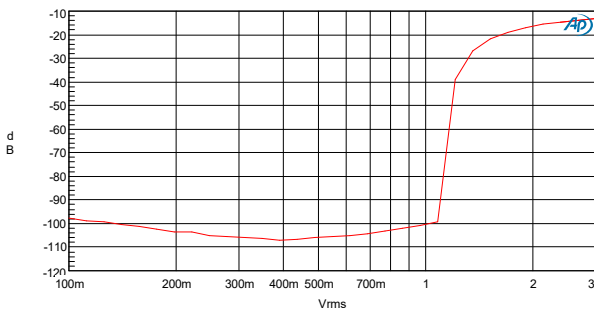

Sweep	Trace	Color	Line Style	Thick	Data	Axis	Comment
1	1	Red	Solid	1	Anlr.TH+N Ratio	Left	

THD+N.at27

**20Hz~20KHz @0.7Vrms, RL=32Ω**

Audio Precision

10/21/16 15:47:23

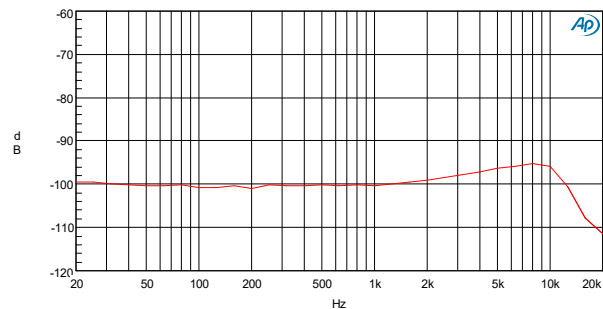

Sweep	Trace	Color	Line Style	Thick	Data	Axis	Comment
1	1	Red	Solid	1	Anlr.TH+N Ratio	Left	

THD+N.at27

Audio Channels' Cross-talk @1Vrms,  $R_L=32\Omega$

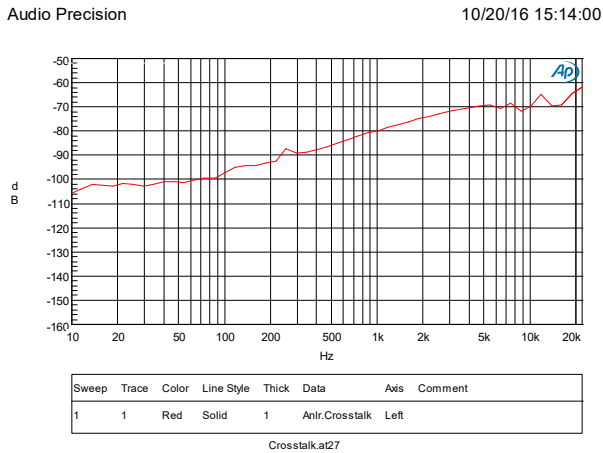

Audio Path OFF-Isolation @0.2Vrms

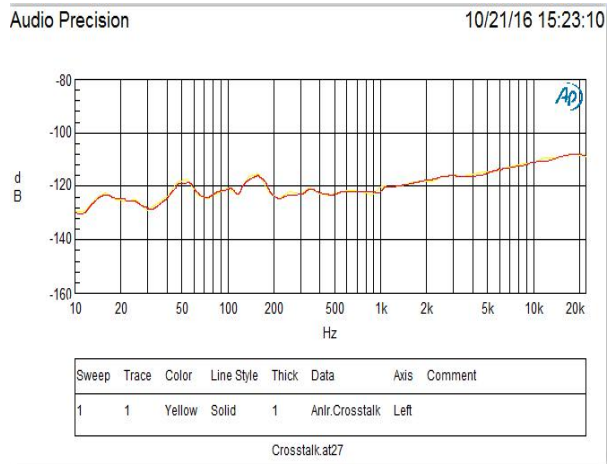

USB Channels' Cross-talk @ $R_L=50\Omega$

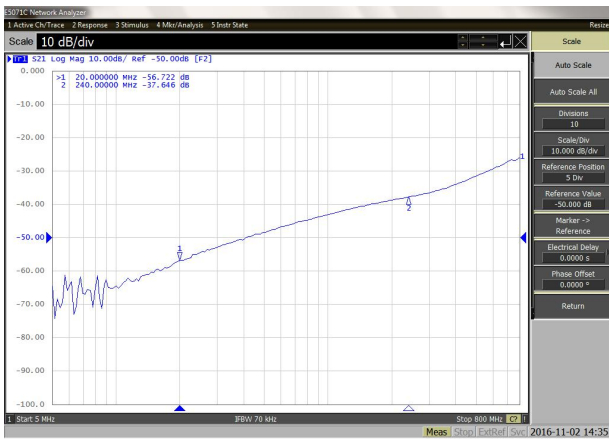

USB Path OFF-Isolation @ $R_L=50\Omega$

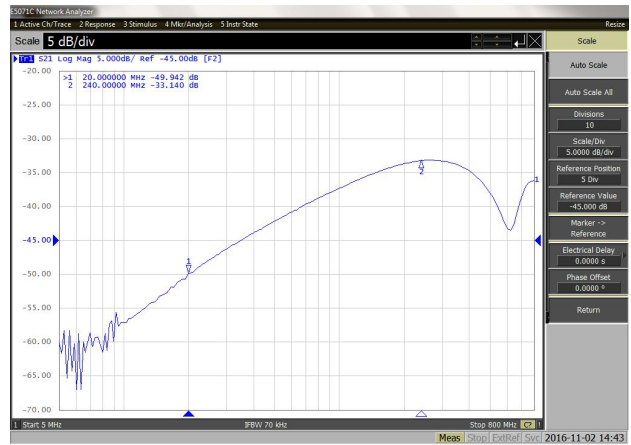

USB Path -3dB Band-width



USB2.0 Eye Diagram

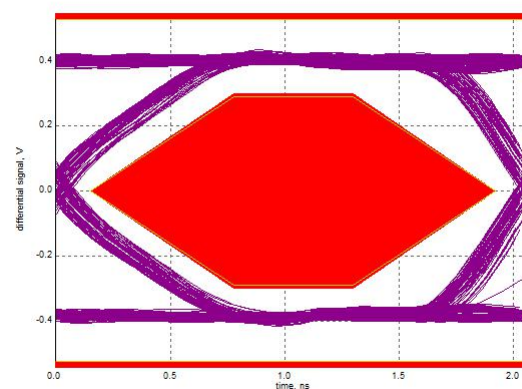

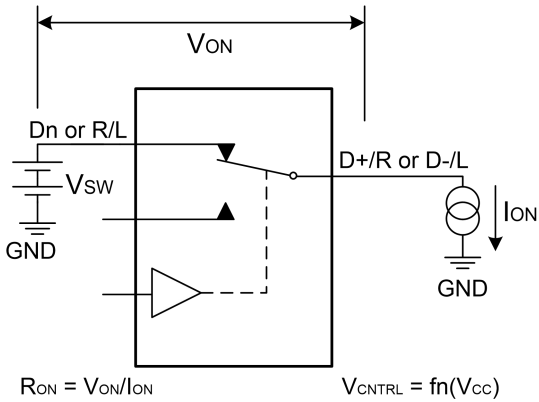
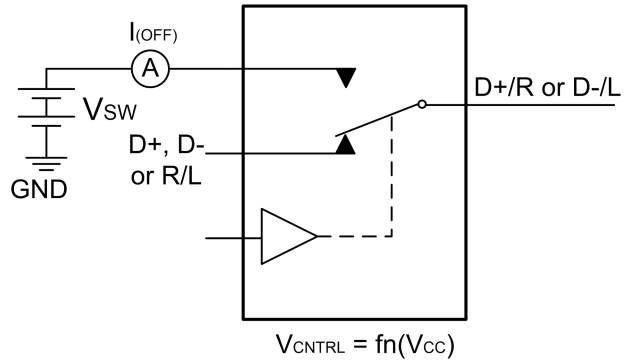
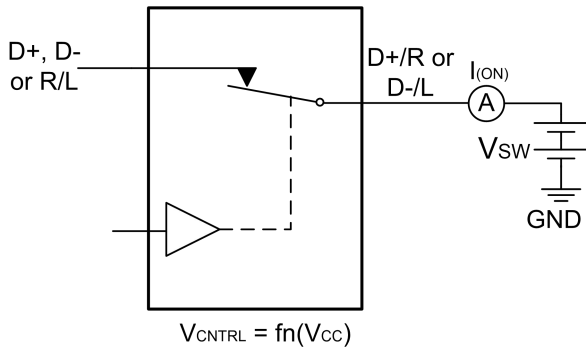
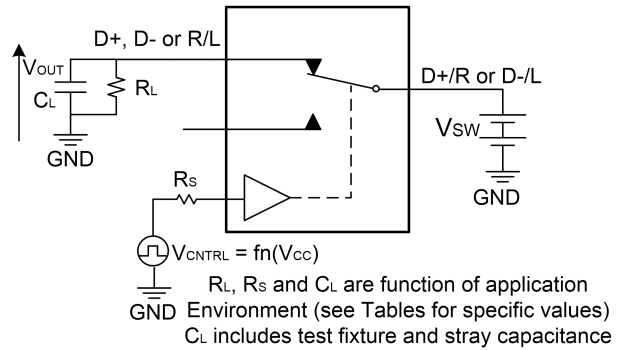
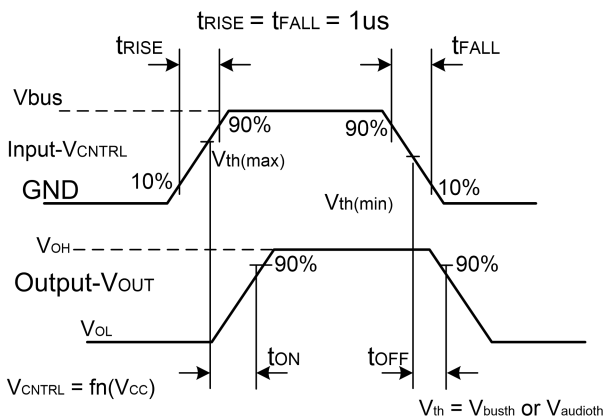
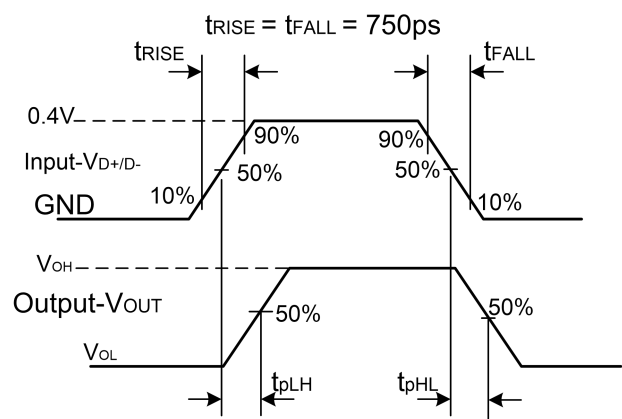
**Test Circuit**

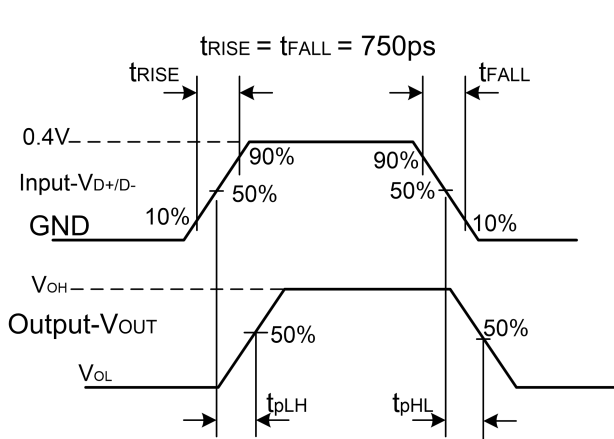
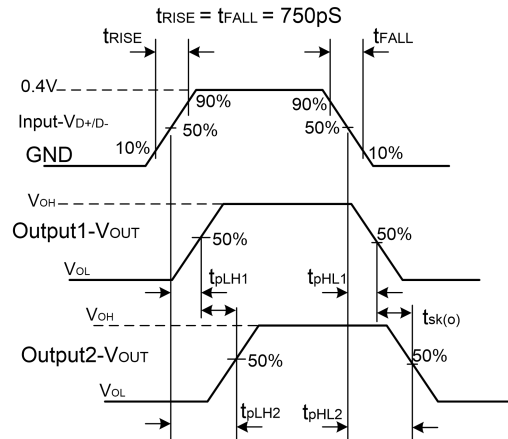
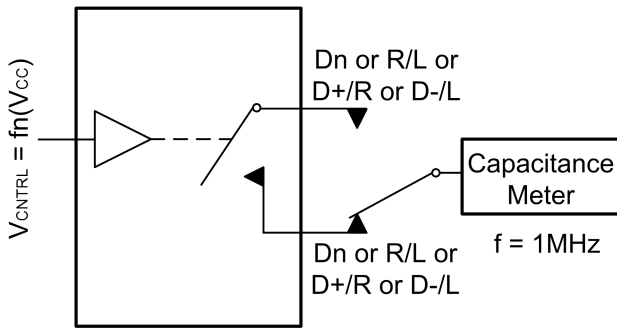
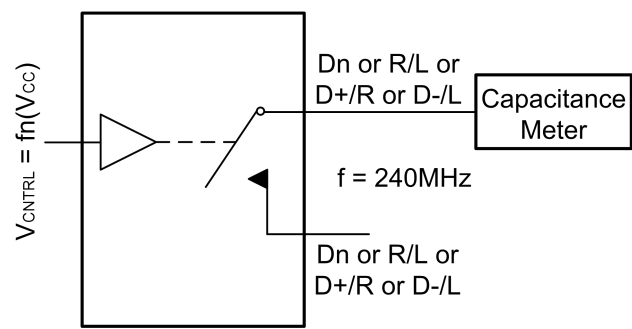
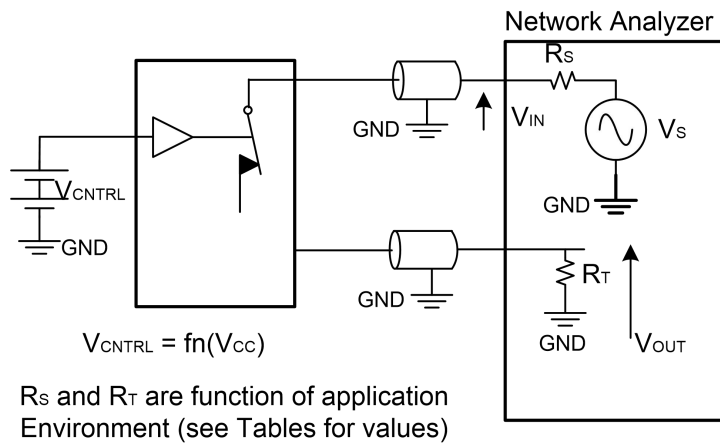
**Figure 4. On Resistance**

**Figure 5. Off Leakage**

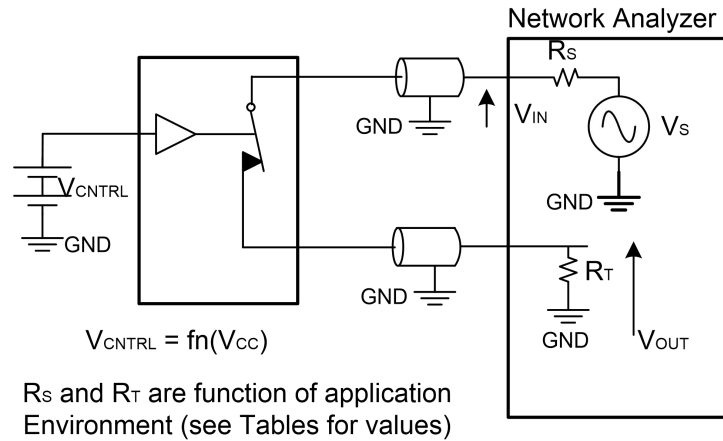
**Figure 6. On Leakage**

**Figure 7. AC Test Circuit Load**

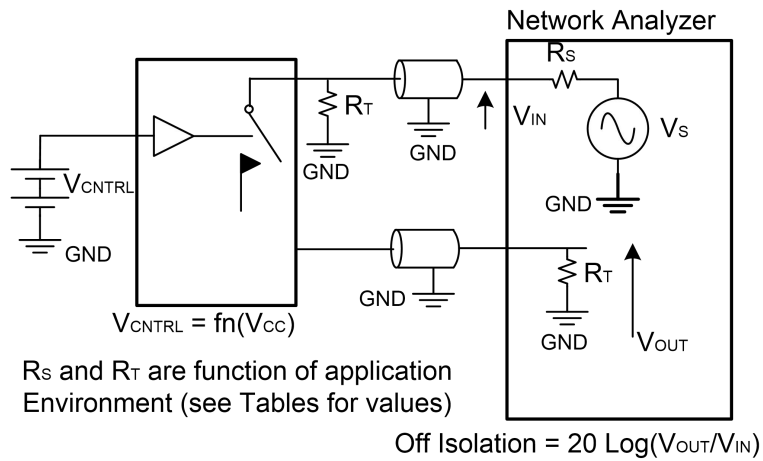
**Figure 8. Turn-On/Turn-Off Waveform (USB/Audio)**

**Figure 7. USB Switch Propagation Delay Waveform**

**Figure 10. Pulse Skew:  $t_{sk(P)} = |t_{pLH} - t_{pLH}|$** 

**Figure 11. Output Skew:  $t_{sk(O)} = |t_{pLH1} - t_{pLH2}|$  or  $|t_{pLH1} - t_{pLH2}|$** 

**Figure 12. Channel Off Capacitance**

**Figure 13. Channel On Capacitance**

**Figure 14. Total Harmonic Distortion**

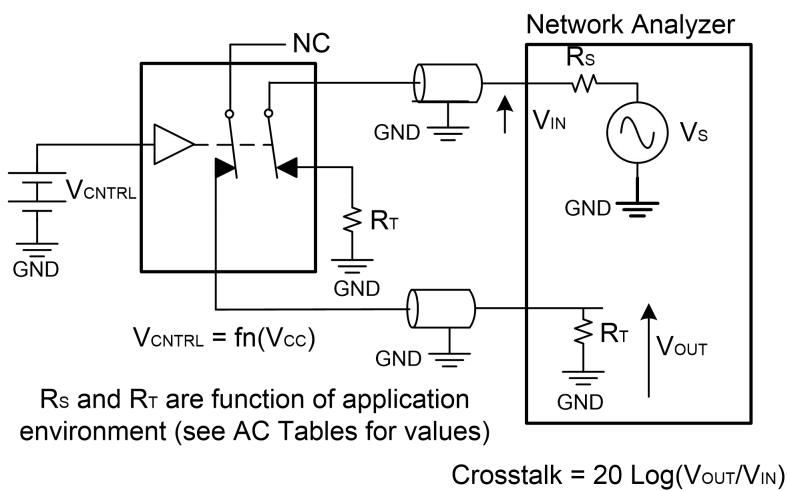



**Figure 15. USB Bandwidth**



**Figure 16. Channel Off Isolation**

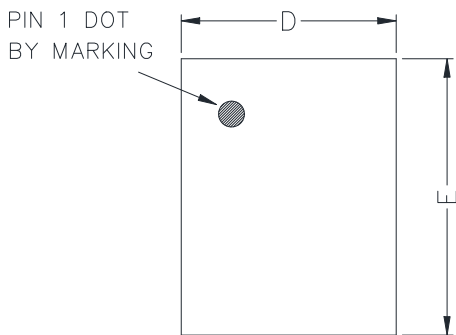

**Figure 17. Non-Adjacent Channel-to-Channel Crosstalk**

**Package outline dimensions**
**QFN1418-10L**

TOP VIEW

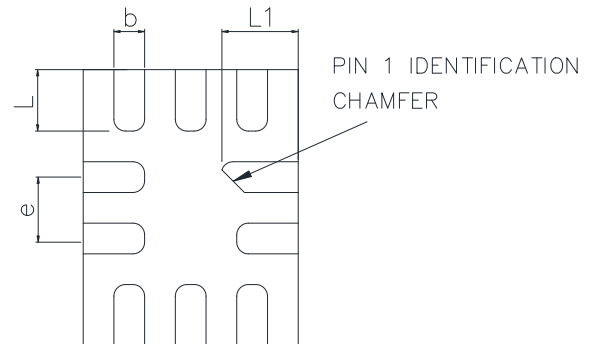

BOTTOM VIEW

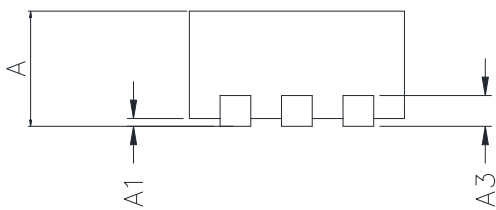

SIDE VIEW

Symbol	Dimensions in Millimeters		
	Min.	Typ.	Max.
A	0.50	0.55	0.60
A1	0.00	-	0.05
A3	0.15 Ref.		
D	1.35	1.40	1.45
E	1.75	1.80	1.85
b	0.15	0.20	0.25
L	0.30	0.40	0.50
L1	0.40	0.50	0.60
e	0.40 BSC		

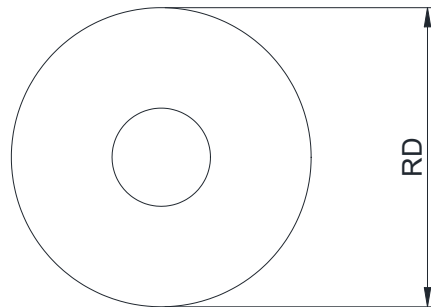
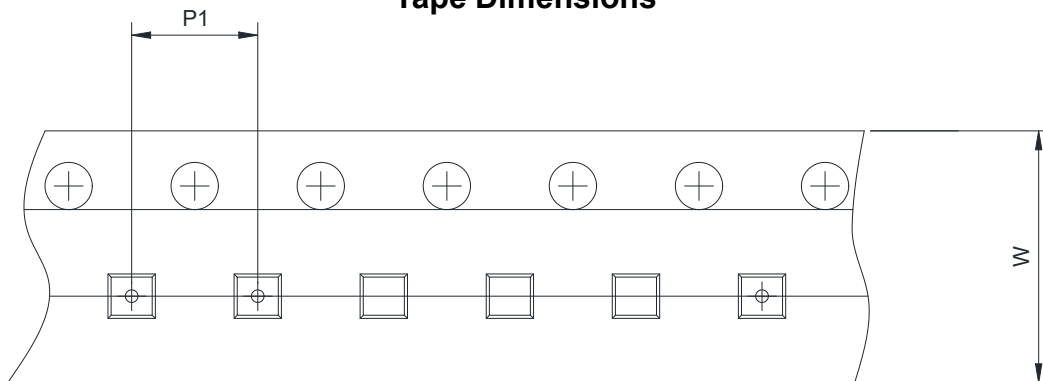
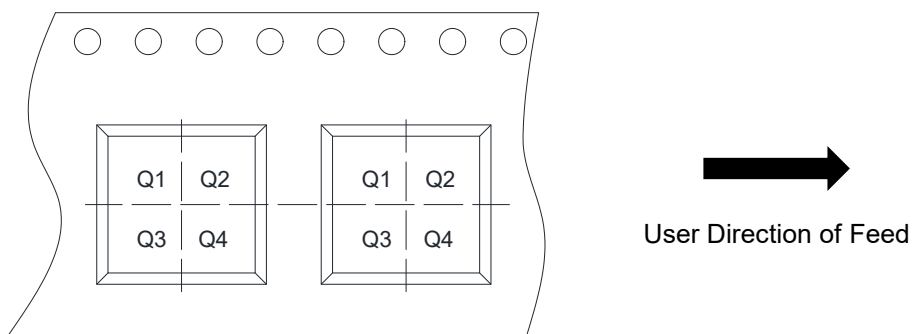
**TAPE AND REEL INFORMATION**
**Reel Dimensions**

**Tape Dimensions**

**Quadrant Assignments For PIN1 Orientation In Tape**

RD	Reel Dimension	<input checked="" type="checkbox"/> 7inch	<input type="checkbox"/> 13inch		
W	Overall width of the carrier tape	<input checked="" type="checkbox"/> 8mm	<input type="checkbox"/> 12mm		
P1	Pitch between successive cavity centers	<input type="checkbox"/> 2mm	<input checked="" type="checkbox"/> 4mm	<input type="checkbox"/> 8mm	
Pin1	Pin1 Quadrant	<input checked="" type="checkbox"/> Q1	<input type="checkbox"/> Q2	<input type="checkbox"/> Q3	<input type="checkbox"/> Q4