

GENERAL DESCRIPTION

OB2550M is a high performance offline PSR controller for low power AC/DC charger and adapter applications. It operates in primary-side sensing and regulation. Consequently, opto-coupler and TL431 could be eliminated. Proprietary Constant Voltage (CV) and Constant Current (CC) control is integrated as shown in the figure below.

In CC control, the current and output power setting can be adjusted externally by the sense resistor R_s at CS pin. In CV control, multi-mode operations are utilized to achieve high performance and high efficiency. In addition, good load regulation is achieved by the built-in cable drop compensation. Device operates in PFM in CC mode at large load condition and it operates in PWM with frequency reduction at light/medium load. The chip consumes very low operation current. It achieves less than 30mW standby power to meet strict standby power standard.

OB2550M offers comprehensive protection coverage with auto-recovery feature including Cycle-by-Cycle current limiting, VDD over voltage protection, feedback loop open protection, short circuit protection, built-in leading edge blanking, VDD under voltage lockout (UVLO), OTP etc. OB2550M is offered in SOT23-6 package.

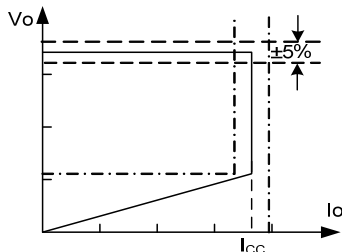
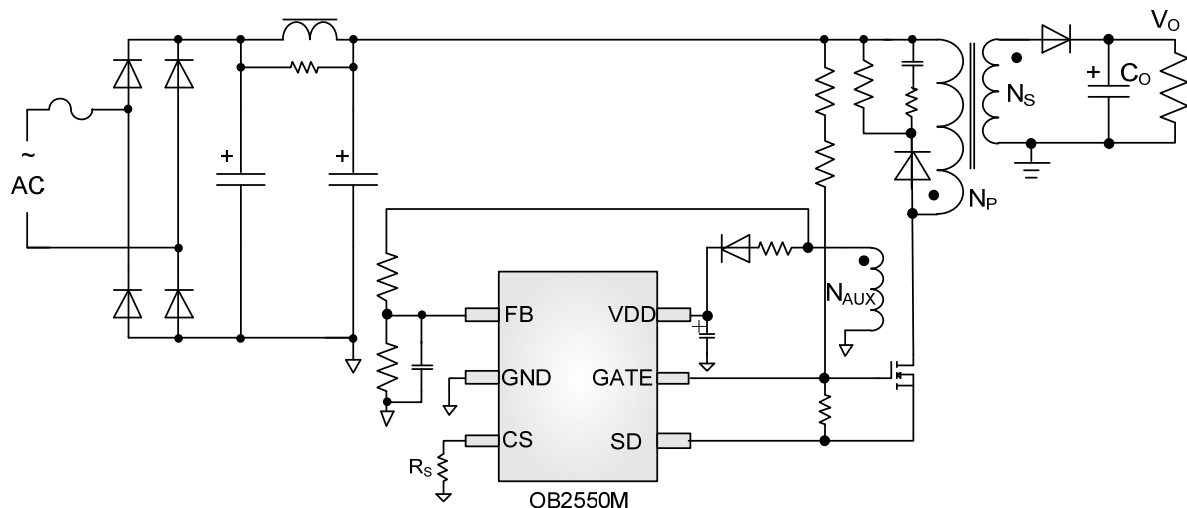

Figure.1. Typical CC/CV Curve

TYPICAL APPLICATION



FEATURES

- Primary-side Sensing and Regulation Without TL431 and Opto-coupler
- High Precision Constant Voltage and Current Regulation at Universal AC Input
- Multi-mode PWM/PFM operation for efficiency improving
- Less than 30mW standby power consumption at 230V with typical application circuit
- Good dynamic response
- Programmable CV and CC Regulation
- Built-in Line Voltage and Primary Winding Inductance Compensation
- Programmable Cable Drop Compensation
- No Need For Control Loop Compensation
- Precise Internal Over Temperature Protection
- Audio Noise Free Operation
- Built-in Leading Edge Blanking (LEB)
- Ultra Low Start-up Current and Low Operating Current
- Comprehensive Protection Coverage with auto-recovery
 - VDD Over Voltage Protection
 - VDD Under Voltage Lockout with Hysteresis (UVLO)
 - Cycle-by-Cycle Current Limiting
 - Feedback Loop Open Protection
 - Output Short Circuit Protection
 - Over Temperature Protection (OTP)

APPLICATIONS

Low Power AC/DC offline SMPS for

- Cell Phone Charger
- Digital Cameras Charger
- Small Power Adapter
- Auxiliary Power for PC, TV etc.
- Linear Regulator/RCC Replacement

GENERAL INFORMATION

Pin Configuration

The pin map is shown as below for SOT23-6.

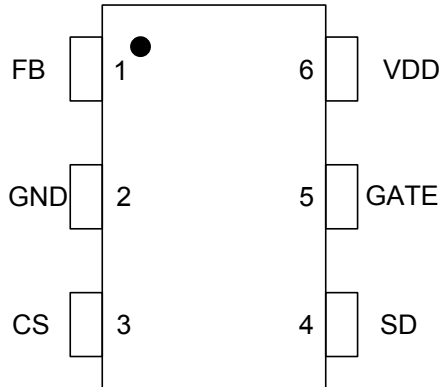

Ordering Information

Part Number	Description
OB2550MMP	SOT23-6, Pb-free, T&R

Package Dissipation Rating

Package	R θ JA (°C/W)
SOT23-6	200

Absolute Maximum Ratings

Parameter	Value
VDD Voltage	-0.3 to 30V
FB Input Voltage	-0.3 to 7V
CS Input Voltage	-0.3 to 7V
SD Input Voltage	-0.3 to 24V
GATE Input Voltage	-0.3 to 24V
Min/Max Operating Junction Temperature T _J	-40 to 150 °C
Operating Temperature T _A Ambient	-20 to 85 °C
Min/Max Storage Temperature T _{stg}	-55 to 150 °C
Lead Temperature (Soldering, 10secs)	260 °C

Note: Stresses beyond those listed under "absolute maximum ratings" may cause permanent damage to the device. These are stress ratings only, functional operation of the device at these or any other conditions beyond those indicated under "recommended operating conditions" is not implied. Exposure to absolute maximum-rated conditions for extended periods may affect device reliability.

Recommended operating condition

Symbol	Parameter	Range
VDD	VDD Supply Voltage	9 to 24V

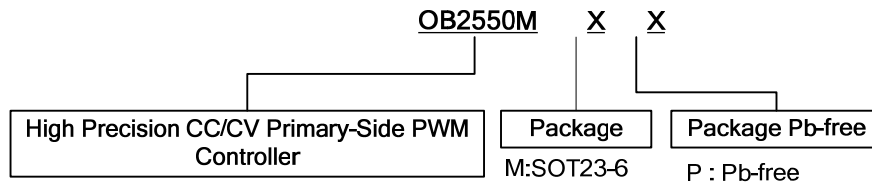

Marking Information

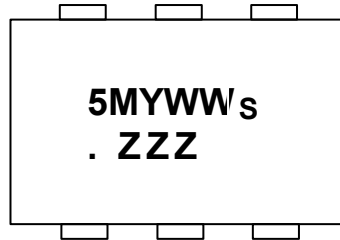

Y:Year Code
 WW:Week Code(01-52)
 s: Internal code
 ZZZ: Lot code

TERMINAL ASSIGNMENTS

Pin Num	Pin Name	I/O	Description
1	FB	I	The voltage feedback from auxiliary winding. Connected to resistor divider from auxiliary winding reflecting output voltage.
2	GND	P	Ground
3	CS	I	Power MOSFET source
4	SD	O	Source driver of power MOSFET
5	GATE	O	Gate driver of power MOSFET.
6	VDD	P	Power Supply

ELECTRICAL CHARACTERISTICS

(TA = 25°C, VDD=15V, if not otherwise noted)

Symbol	Parameter	Test Conditions	Min	Typ.	Max	Unit
Supply Voltage (VDD) Section						
I _{start-up}	Start up current	VDD=UVLO_OFF-1V		5	15	uA
I _{static}	Static current			0.65	1.0	mA
UVLO(OFF)	VDD under voltage lockout exit		13.8	14.8	15.8	V
UVLO(ON)	VDD under voltage lockout enter		7.0	7.6	8.2	V
VDD_OVP	VDD over voltage protection		25.2	26.2	27.2	V
Max. Operating Voltage					24	V
Current Sense Input Section						
TLEB	LEB time			330		ns
TD_OC	OCP propagation delay			100		ns
V _{th_ocp_min}	Minimum over current threshold		485	500	515	mV
V _{th_ocp_max}	Maximum over current threshold			565		mV
V _{cs_mini}	Minimum CS threshold			100		mV
T _{on_max}	Maximum Ton			50		us
T _{d_oc}	OCP propagation delay			100		ns
FB Input Section						
V _{ref_fb}	Reference voltage for feedback threshold		2.475	2.50	2.525	V
T _{pause_min}	Minimum Toff			2.0		us
F _{min}	Minimum frequency		400	450	500	Hz
I _{comp_cable}	Maximum cable compensation current		22	24	26	uA
Gate Drive Section						
V _{clamp}	Output clamp voltage level		12	13.5	15	V
T _r	Output rising time	CL=0.22nF		370		ns
T _f	Output falling time	CL=0.22nF		60		ns
R _{dson_l}	Internal switch on resistor			1.0	2	Ω
I _{sw_leak}	Before startup, SD pin leakage current	V _{sw} =VDD-1V			1	uA
Output Over Voltage Protection						
V _{OVP}	Output Over voltage threshold		2.9	3.0	3.1	V
On chip Over temperature Section						
T _{otp}	Over temperature trigger point		150	165	180	°C
T _{otp_rec}	Over temperature recovery point		115	130	145	°C

CHARACTERIZATION PLOTS

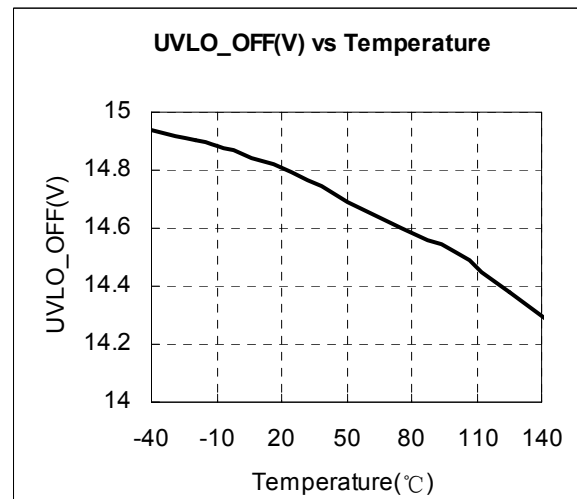
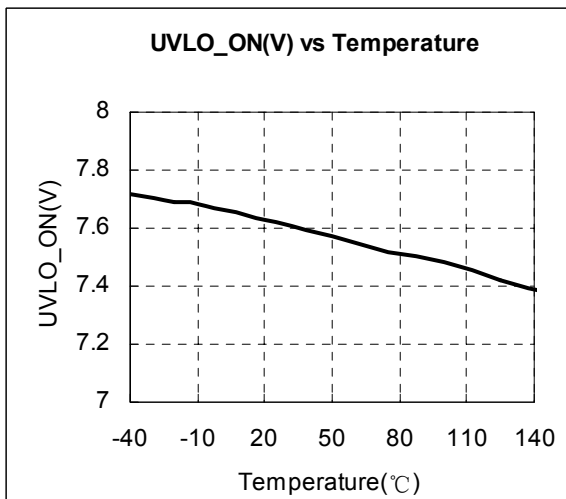
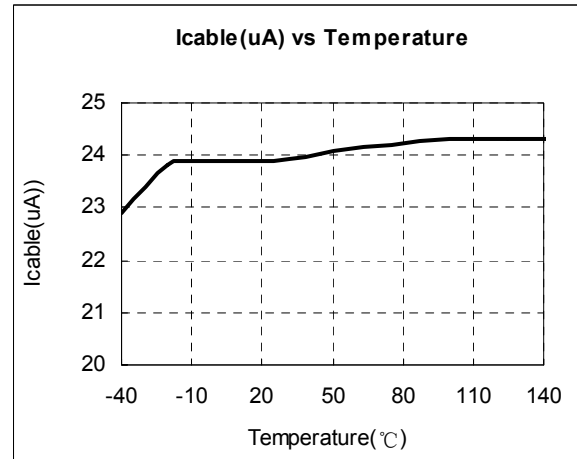
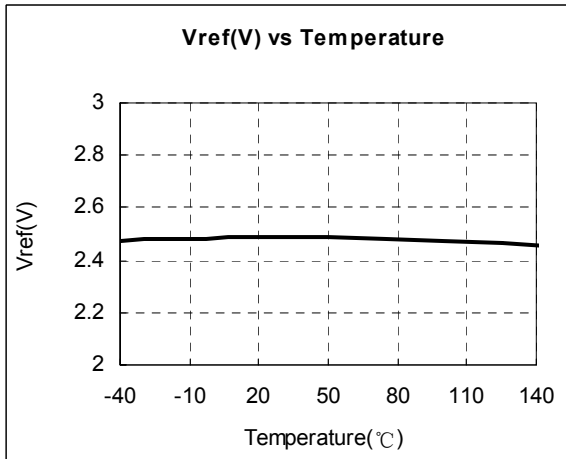
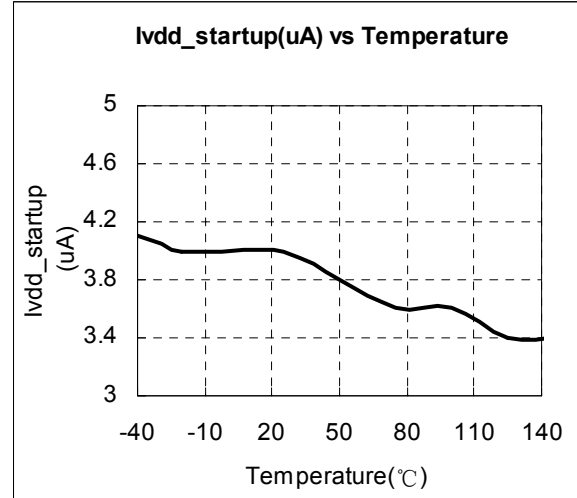
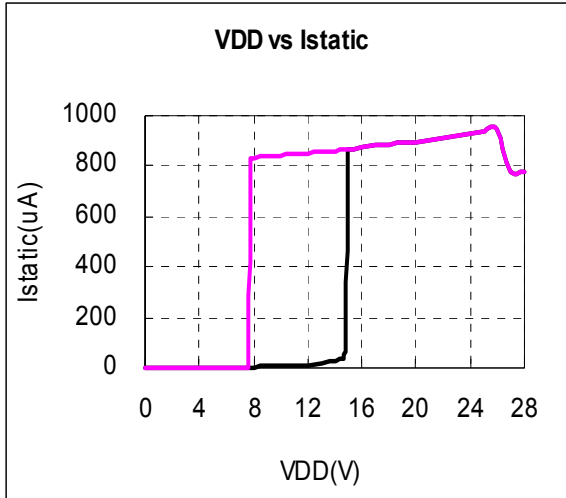

PACKAGE MECHANICAL DATA

SOT-23-6L PACKAGE OUTLINE DIMENSIONS

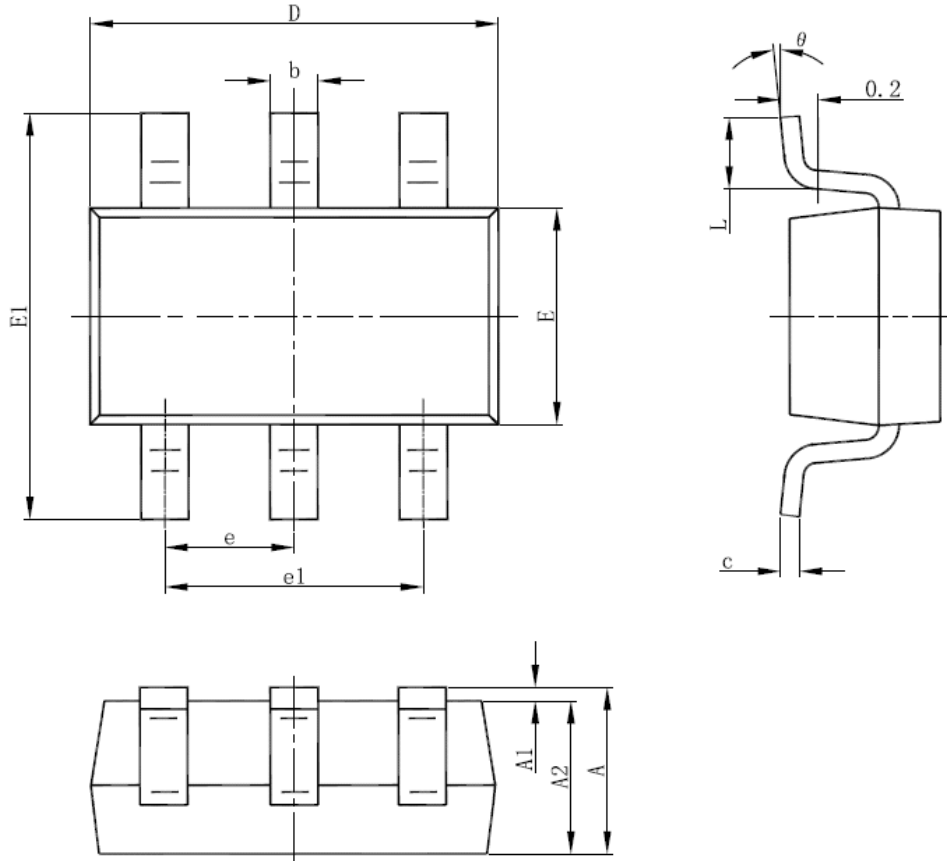

Symbol	Dimensions In Millimeters		Dimensions In Inches	
	Min	Max	Min	Max
A	1.000	1.450	0.039	0.057
A1	0.000	0.150	0.000	0.006
A2	0.900	1.300	0.035	0.051
b	0.300	0.500	0.012	0.020
c	0.080	0.220	0.003	0.009
D	2.800	3.020	0.110	0.119
E	1.500	1.726	0.059	0.068
E1	2.600	3.000	0.102	0.118
e	0.950 (BSC)		0.037 (BSC)	
e1	1.800	2.000	0.071	0.079
L	0.300	0.600	0.012	0.024
θ	0°	8°	0°	8°

IMPORTANT NOTICE

RIGHT TO MAKE CHANGES

On-Bright Electronics Corp. reserves the right to make corrections, modifications, enhancements, improvements and other changes to its products and services at any time and to discontinue any product or service without notice. Customers should obtain the latest relevant information before placing orders and should verify that such information is current and complete.

WARRANTY INFORMATION

On-Bright Electronics Corp. warrants performance of its hardware products to the specifications applicable at the time of sale in accordance with its standard warranty. Testing and other quality control techniques are used to the extent it deems necessary to support this warranty. Except where mandated by government requirements, testing of all parameters of each product is not necessarily performed.

On-Bright Electronics Corp. assumes no liability for application assistance or customer product design. Customers are responsible for their products and applications using On-Bright's components, data sheet and application notes. To minimize the risks associated with customer products and applications, customers should provide adequate design and operating safeguards.

LIFE SUPPORT

On-Bright Electronics Corp.'s products are not designed to be used as components in devices intended to support or sustain human life. On-bright Electronics Corp. will not be held liable for any damages or claims resulting from the use of its products in medical applications.

MILITARY

On-Bright Electronics Corp.'s products are not designed for use in military applications. On-Bright Electronics Corp. will not be held liable for any damages or claims resulting from the use of its products in military applications.