

Features

- Input voltage range: 2.2 to 6V
- Programmable LED Current
- Drives LEDs Up to 27V
- Switching Frequency: up to 800KHz
- Wide dimming frequency range: 20KHz~360 KHz
- Programmable Overvoltage Protection
- Tiny SOP8/PP Package

Applications

- PDA
- Cellular Phones
- Handheld Devices
- MP3 Players
- GPS Receivers

Description

The HX3248C is a step-up DC/DC converter with a constant current to drive white LEDs or similar. The device can drive up to eight LEDs in series from a Li-Ion cell. The LED current is set by the external resistor (R_{SET}) and is directly regulated by the feedback (FB) voltage (typ: 200mV) across the external resistor R_{SET} .

To ensure maximum safety during operation, the output has integrated overvoltage protection that prevents damage to the device in case of some fault conditions. The OVP voltage can be programmed by two external resistors.

The HX3248C is available in a tiny SOP8/PP package.

Typical Application Circuit

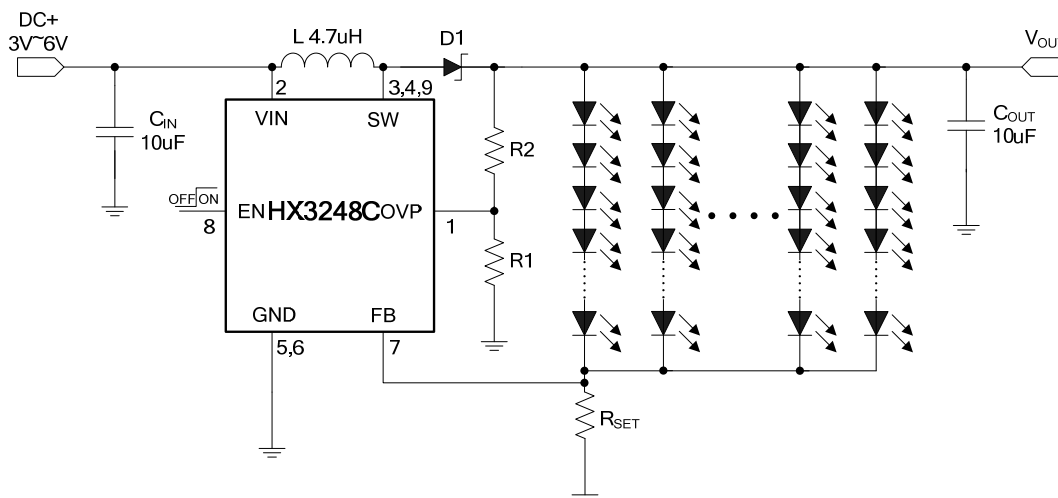

* $I_{LED} = 200mV / R_{SET}$

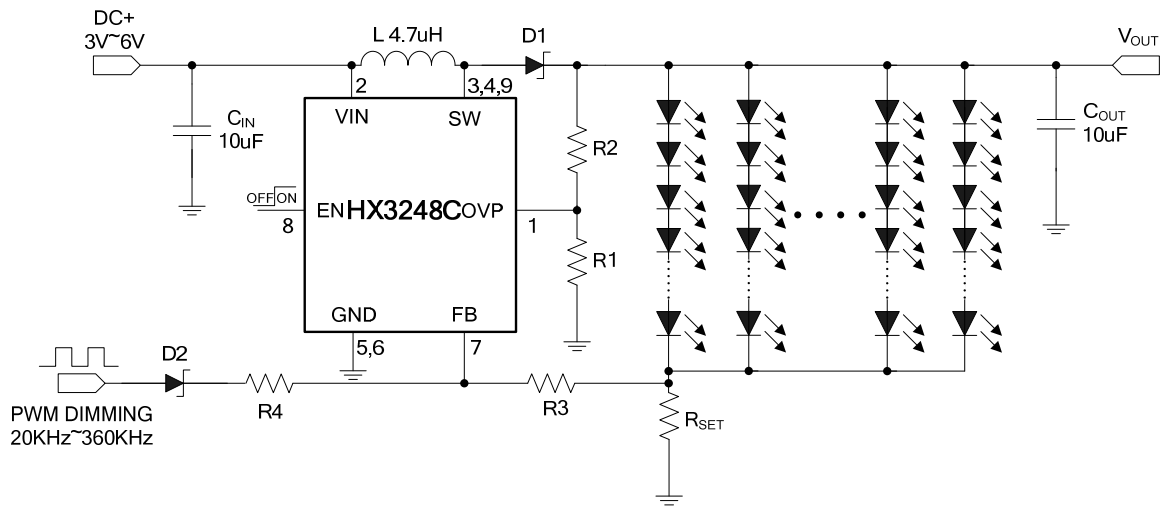

* This application circuit is applied to PWM dimming.

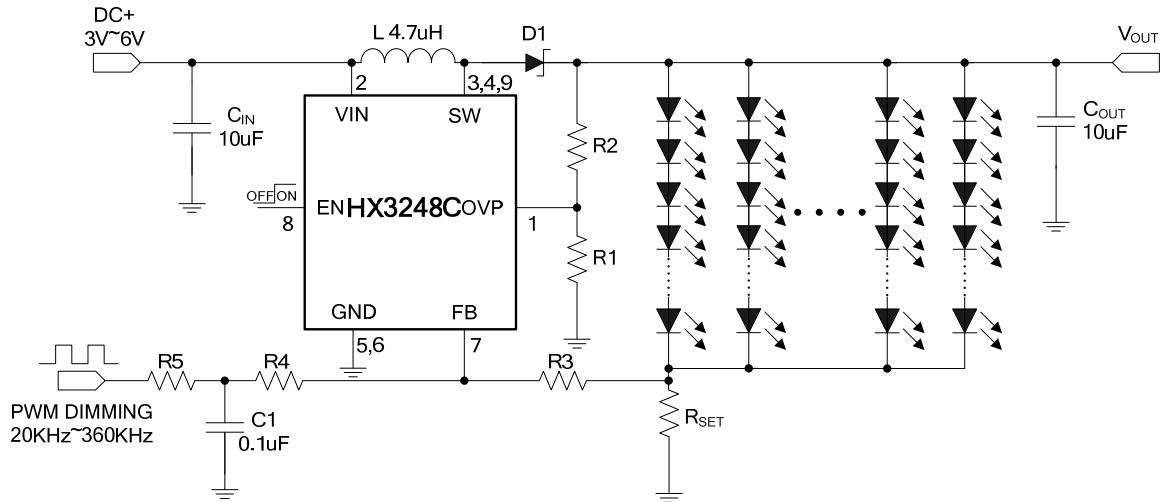

* This application circuit is applied to PWM dimming.

Absolute Maximum Ratings (Note1)

Supply Voltage.....	7V
SW Voltage.....	36V
FB Voltage.....	7V
EN Voltage.....	7V
OVP Voltage.....	7V
Operating Temperature Range (Note 2)	-40°C to 85°C
Maximum Junction Temperature.....	125°C
Storage Temperature Range	-65°C to 150°C
Lead Temperature (Soldering, 10 sec).....	300°C

Note 1: Stresses beyond those listed under Absolute Maximum Ratings may cause permanent damage to the device. Exposure to any Absolute Maximum Rating condition for extended periods may affect device reliability and lifetime.

Note 2: The HX3248C is guaranteed to meet performance specifications from 0°C to 85°C. Specifications over the -40°C to 85°C operating temperature range are assured by design, characterization and correlation with statistical process controls.

Pin Assignment

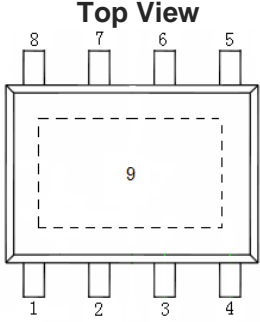
	PIN	NAME	FUNCTION
	1	OVP	Overvoltage protection Pin
2	VIN	Input Supply Pin	
3,4,9	SW	Switch Output Pin	
5,6	GND	Ground	
7	FB	Feedback Pin	
8	EN	ON/OFF Control (High Enable)	

*EXPOSED PAD (PIN 9) IS SW, MUST BE SOLDERED TO PCB.

Electrical Characteristics

Operating Conditions: $V_{IN} = 3V$, $T_A = 25^{\circ}C$, unless otherwise specified.

SYMBOL	PARAMETER	CONDITIONS	MIN	TYP	MAX	UNITS
V_{IN}	Operating Voltage Range		2.2		6	V
V_{FB}	Feedback Voltage	$T_A = 25^{\circ}C$, $I_{LOAD} = 1mA$		200		mV
I_{FB}	FB Pin Bias Current	EN=GND		60		nA
I_Q	Operating quiescent current into VIN	$I_{OUT} = 0 mA$, not switching		100		uA
$I_{SD(OUT)}$	Shutdown current			20		uA
F_{SW}	Switching Frequency			800		KHz
V_{SW}	Maximum switch voltage			30		V
$R_{ds(ON)}$	MOSFET on-resistance			50		m Ω
DC	Maximum Duty Cycle			90		%
V_{OVP}	Output overvoltage protection	V_{OUT} rising		1.212		V
V_{ENL}	EN Falling Threshold			0.5		V
V_{ENH}	EN Rising Threshold			0.7		V

Typical Performance Characteristics

Operating Conditions: $T_A = 25^\circ\text{C}$, $V_{IN} = 5\text{V}$, $R_{SET} = 0.68\Omega$, 8PCS LED Series, unless otherwise specified.

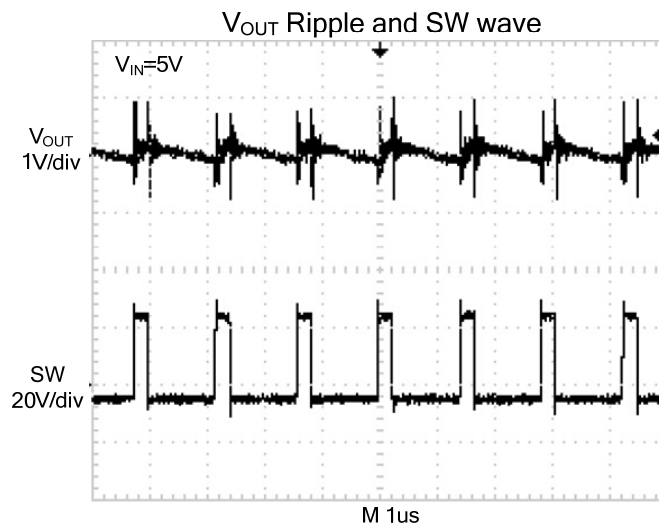
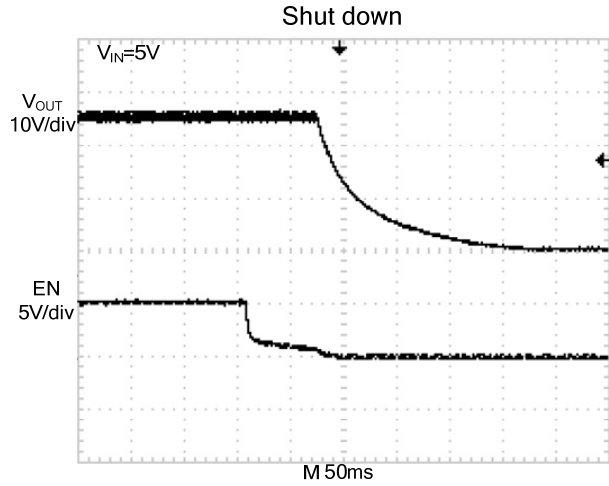
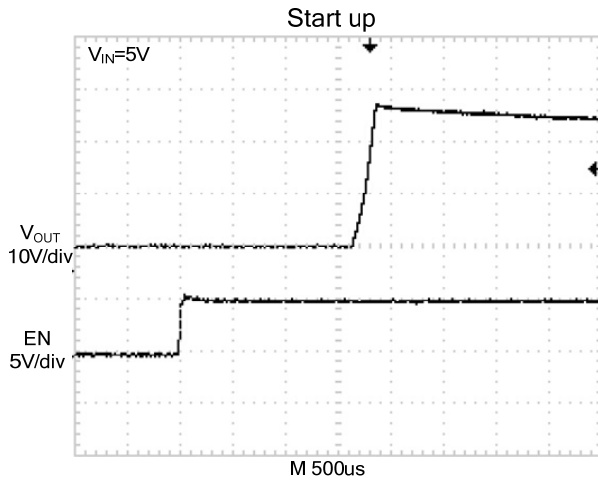
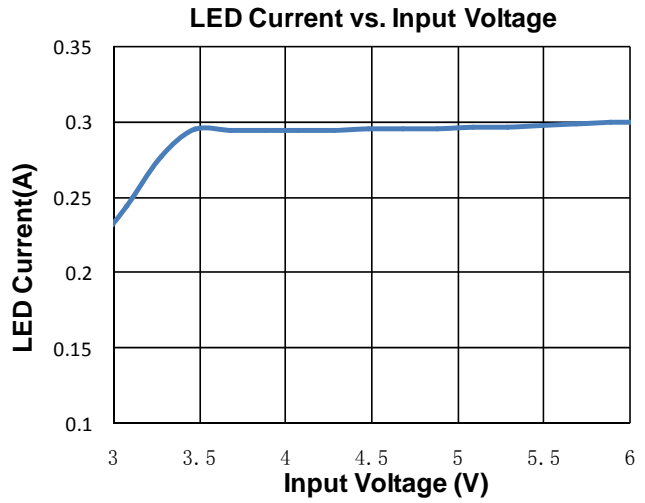
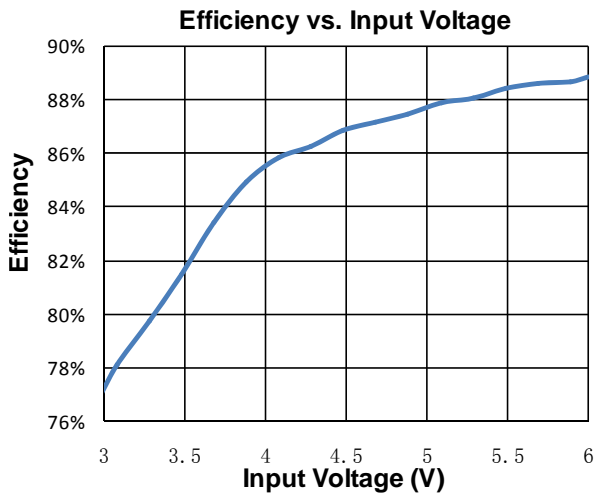

Block Diagram

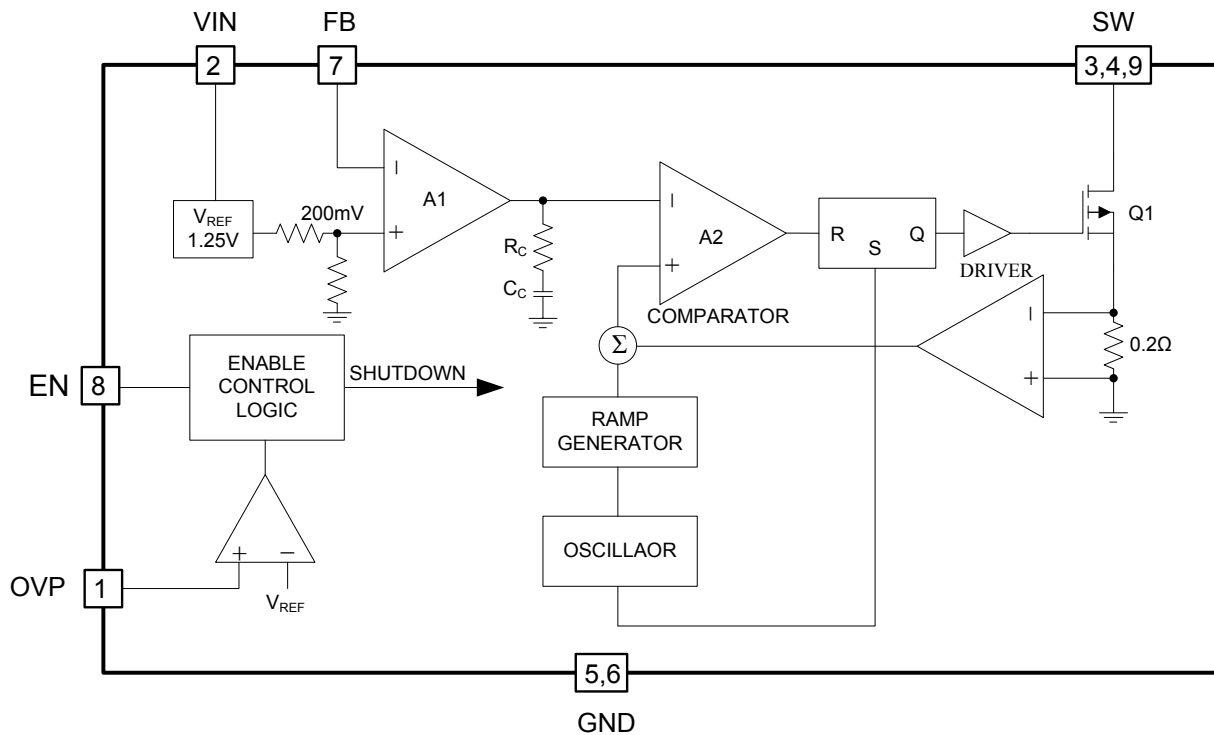

Pin Functions

PIN	NAME	FUNCTION
1	OVP	Overvoltage protection Pin. Programs VOUT overvoltage protection level (OVP) to protect device.
2	VIN	Input Supply Pin. Must be locally bypassed.
3,4,9	SW	Switch Pin. Connect inductor/diode here. Minimize trace area at this pin to reduce EMI.
5,6	GND	Ground Pin.
7	FB	Feedback Pin. Reference voltage is 200mV. Connect cathode of lowest LED and resistor here. Calculate resistor value according to the formula: $R_{SET} = 200mV/I_{LED}$.
8	EN	Shutdown Pin. Connect to 1.5V or higher to enable device; 0.5V or less to disable device.

Application Information

Operation

The HX3248C operates in a constant frequency, current mode like a standard boost converter but regulates the voltage across the external resistor (R_{SET}) instead of the output voltage. This gives an accurate regulated LED current independent of the input voltage and number of LEDs connected. With integrated overvoltage protection (OVP), the HX3248C is configured as a current source with overvoltage protection ideally suited to drive LEDs. The device can drive up to eight serial LEDs with the internal switch.

LED Current Control

The LED current is controlled by the feedback resistor (R_{SET}). The feedback reference is 200mV. The LED current is $200\text{mV} / R_{SET}$. In order to have accurate LED current, precision resistors are preferred (1% is recommended).

Dimming Control

With the PWM signal applied to the FB pin, the HX3248C is turned on or off by the PWM signal. The LEDs operate at either zero or full current. The average LED current increases proportionally with the duty cycle of the PWM signal. A 0% duty cycle will turn off the HX3248C and corresponds to zero LED current. A 100% duty cycle corresponds to full current. The typical frequency range of the PWM signal is 20kHz to 360kHz. These are two kinds of dimming control circuits shown in figure 1 and figure 2.

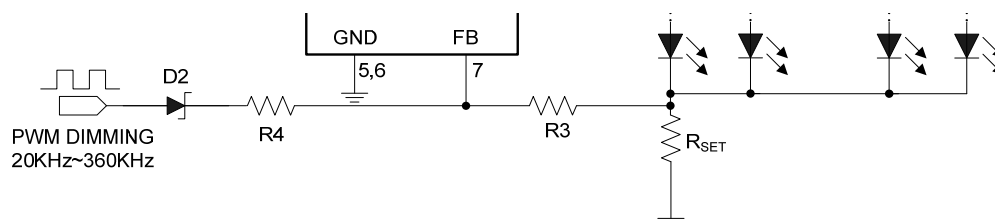

Figure 1: PWM Dimming control circuit

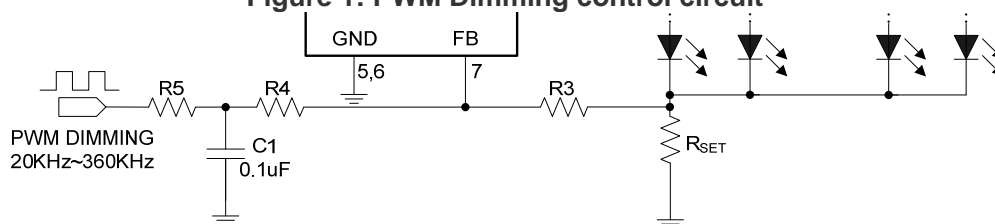

Figure 2: PWM Dimming control circuit

Diode Selection

The high switching frequency of HX3248C demands a high-speed rectifier diode. For most applications, Schottky diodes are recommended because of their fast recovery time and low forward voltage. Moreover, the diode reverse breakdown voltage must exceed V_{OUT} . In general, use a high-speed silicon rectifier diode with adequate reverse voltage.

Inductor Selection

The selection of the inductor together with the nominal LED current, input, and output voltage of the

application determines the switching frequency of the converter. Because of the HX3248C's high switching frequency, inductors with a ferrite core or equivalent are recommended. Powdered iron cores are not recommended due to their high losses at frequencies over 50KHz.

Output and Input Capacitors Selection

Larger output capacitors reduce noise and improve load-transient response, stability, and power-supply rejection. Since output ripple in boost DC-DC designs is dominated by capacitor equivalent series resistance (ESR), Low-ESR capacitors must be used.

The input capacitor (C_{IN}) reduces the current peaks caused by the input supply and reduces noise injection. Its value is largely determined by the source impedance of the input supply. High source impedance requires high input capacitance, particularly at the input voltage falls. At low input voltage, increasing C_{IN} or lowering its ESR can improve efficiency. Using the same capacitance value for C_{IN} as for C_{OUT} is a good start.

The C_{OUT} ESR affects loop stability by introducing a left half-plane zero. A small capacitor C1 between FB and GND forms a pole with the feedback resistance that cancels the ESR zero. This small capacitor C1 and provide sufficient compensation for the loop.

Overvoltage Protection (OVP)

As with any current source, the output voltage rises as the output impedance increases or is disconnected. To prevent the output voltage from exceeding the maximum main switch (Q1) voltage rating of 36V, an overvoltage protection circuit is integrated. When the output voltage exceeds the OVP threshold voltage, (Q1) turns off. The converter switch remains off until the output voltage falls below the OVP threshold voltage. As long as the output voltage is below the OVP threshold the converter continues its normal operation, until the output voltage exceeds the OVP threshold again.

Packaging Information

SOP8/PP (EXP PAD) Package Outline Dimension

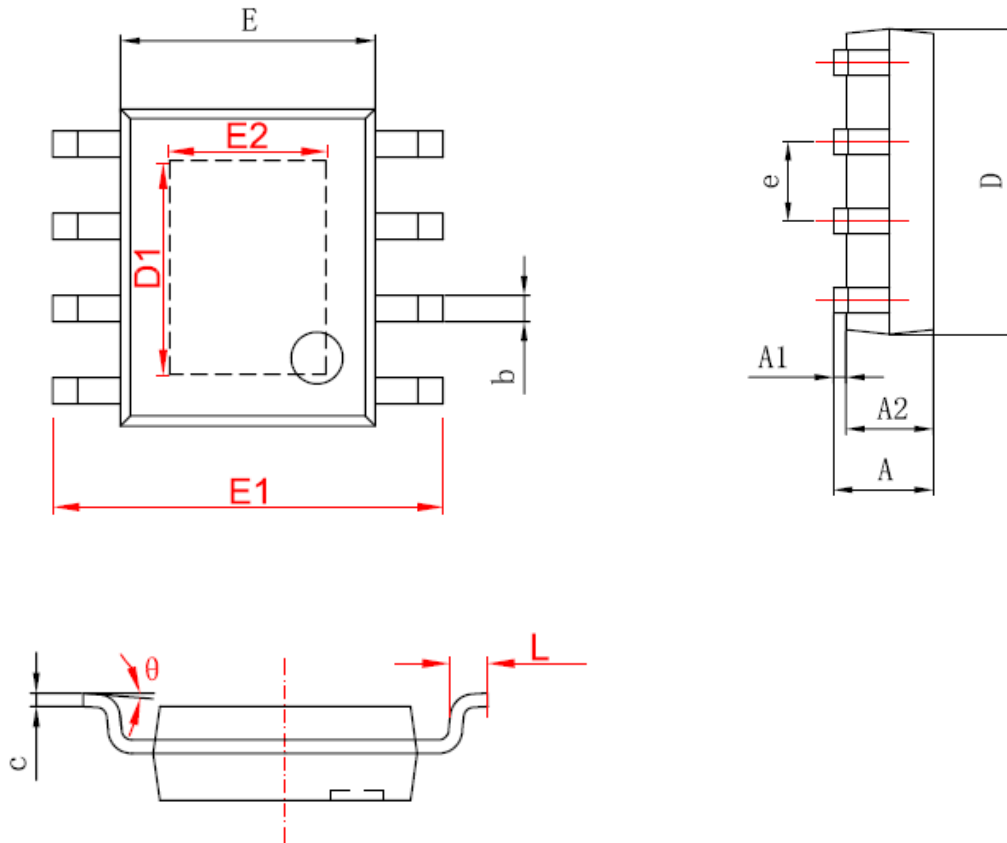

Symbol	Dimensions In Millimeters		Dimensions In Inches	
	Min	Max	Min	Max
A	1.350	1.750	0.053	0.069
A1	0.050	0.150	0.004	0.010
A2	1.350	1.550	0.053	0.061
b	0.330	0.510	0.013	0.020
c	0.170	0.250	0.006	0.010
D	4.700	5.100	0.185	0.200
D1	3.202	3.402	0.126	0.134
E	3.800	4.000	0.150	0.157
E1	5.800	6.200	0.228	0.244
E2	2.313	2.513	0.091	0.099
e	1.270(BSC)		0.050(BSC)	
L	0.400	1.270	0.016	0.050
theta	0°	8°	0°	8°

Subject changes without notice.