

Apr.1.2020 Copyright 2020 HIROSE ELECTRIC CO., LTD. All Rights Reserved.  
 In case of consideration for using Automotive equipment / device which demand high reliability, kindly contact our sales window correspondents.

| 1     |                          |  |  |  | 2  |      |      |       |                          | 3 |  |  |    |      | 4    |  |  |  |  |
|-------|--------------------------|--|--|--|----|------|------|-------|--------------------------|---|--|--|----|------|------|--|--|--|--|
| COUNT | DESCRIPTION OF REVISIONS |  |  |  | BY | CHKD | DATE | COUNT | DESCRIPTION OF REVISIONS |   |  |  | BY | CHKD | DATE |  |  |  |  |
| △     |                          |  |  |  |    |      | ..   | △     |                          |   |  |  |    |      | ..   |  |  |  |  |
| △     |                          |  |  |  |    |      |      | △     |                          |   |  |  |    |      | ..   |  |  |  |  |
| △     |                          |  |  |  |    |      |      | △     |                          |   |  |  |    |      | ..   |  |  |  |  |

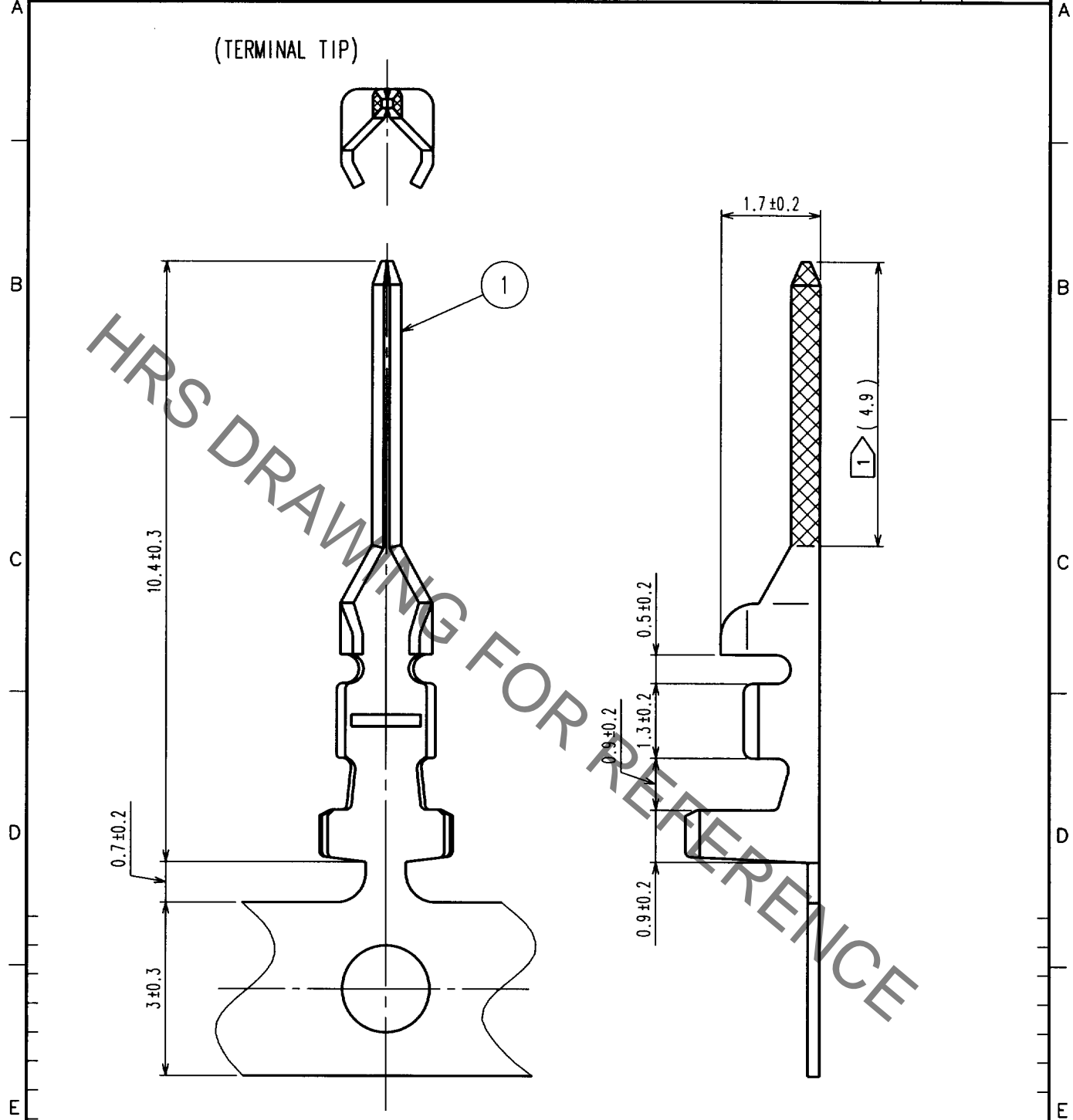

NOTES 1 GOLD PLATING AREA  
 2 10000 UNITS PER REEL.

|   |                 |  |
|---|-----------------|--|
| 1 | PHOSPHOR BRONZE | CONTACT AREA: GOLD PLATED<br>CRIMPING AREA: NICKEL PLATING |
|---|-----------------|--|

| NO. | MATERIAL | FINISH, REMARKS | NO. | MATERIAL | FINISH, REMARKS |
|-----|----------|-----------------|-----|----------|-----------------|
|-----|----------|-----------------|-----|----------|-----------------|

|                |  |  |            |            |            |             |          |
|----------------|--|--|------------|------------|------------|-------------|----------|
| CODE NO. (OLD) |  |  | DRAWN      | DESIGNED   | CHECKED    | APPROVED    | RELEASED |
|                |  |  | S. Hara    | F. Asai    | C. Hanami  | K. Katayama |          |
|                |  |  | '00. 6. 19 | '00. 6. 19 | '00. 6. 19 | '00. 6. 19  |          |

|                                    |              |                 |
|------------------------------------|--------------|-----------------|
| <br>SACLE<br>10 : 1<br>UNITS<br>mm | DRAWING NO.  | PART NO.        |
|                                    | EDC4-071511  | DF11-EP2428PCFA |
| <br>HIROSE ELECTRIC CO., LTD.      | CODE NO.     | 1/1             |
|                                    | CL543-0617-0 |                 |

|    |
|----|
| TO |
|    |
|    |
|    |