

Absolute Maximum Ratings T_A = 25°C unless otherwise noted

Symbol	Parameter	Value	Units
P _D	Power Dissipation	200	mW
T _{STG}	Storage Temperature Range	-65 to +150	°C
T _{OPR}	Operating Temperature Range	-65 to +150	°C

These ratings are limiting values above which the serviceability of the diode may be impaired.

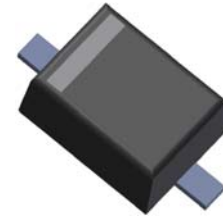

SOD-323 Flat Lead

Specification Features:

- Wide Zener Voltage Range Selection, 2.4V to 75V
- VZ Tolerance Selection of ±2% (B Series)
- Flat Lead SOD-323 Small Outline Plastic Package
- Surface Device Type Mounting
- RoHS Compliant
- Matte Tin(Sn) Lead Finish
- Band Indicates Cathode

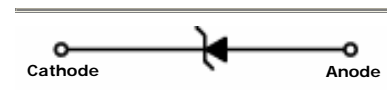

ELECTRICAL SYMBOL

Electrical Characteristics T_A = 25°C unless otherwise noted

Device Type	Device Marking		V _Z @ I _{ZT} (Volts)			I _{ZT} (mA)	Z _{ZT} @ I _{ZT} (Ω) Max	I _{ZK} (mA)	Z _{ZK} @ I _{ZK} (Ω) Max	I _R @ V _R (μA) Max	V _R (Volts)
			Min	Nom	Max						
MM3Z2V4BW	2.4	0Z	2.35	2.4	2.45	5	100	1	564	45	1
MM3Z2V7BW	2.7	1Z	2.65	2.7	2.75	5	100	1	564	18	1
MM3Z3V0BW	3.0	2Z	2.94	3.0	3.06	5	100	1	564	9	1
MM3Z3V3BW	3.3	3Z	3.23	3.3	3.37	5	95	1	564	4.5	1
MM3Z3V6BW	3.6	4Z	3.53	3.6	3.67	5	90	1	564	4.5	1
MM3Z3V9BW	3.9	5Z	3.82	3.9	3.98	5	90	1	564	2.7	1
MM3Z4V3BW	4.3	6Z	4.21	4.3	4.39	5	90	1	564	2.7	1
MM3Z4V7BW	4.7	7Z	4.61	4.7	4.79	5	80	1	470	2.7	2
MM3Z5V1BW	5.1	8Z	5.00	5.1	5.20	5	60	1	451	1.8	2
MM3Z5V6BW	5.6	9Z	5.49	5.6	5.71	5	40	1	376	0.9	2
MM3Z6V2BW	6.2	AZ	6.08	6.2	6.32	5	10	1	141	2.7	4
MM3Z6V8BW	6.8	BZ	6.66	6.8	6.94	5	15	1	75	1.8	4
MM3Z7V5BW	7.5	CZ	7.35	7.5	7.65	5	15	1	75	0.9	5
MM3Z8V2BW	8.2	DZ	8.04	8.2	8.36	5	15	1	75	0.63	5
MM3Z9V1BW	9.1	EZ	8.92	9.1	9.28	5	15	1	94	0.45	6
MM3Z10VBW	10.	FZ	9.80	10	10.20	5	20	1	141	0.18	7
MM3Z11VBW	11.	GZ	10.78	11	11.22	5	20	1	141	0.09	8
MM3Z12VBW	12.	HZ	11.76	12	12.24	5	25	1	141	0.09	8
MM3Z13VBW	13.	JZ	12.74	13	13.26	5	30	1	160	0.09	8
MM3Z15VBW	15.	KZ	14.70	15	15.30	5	30	1	188	0.045	10.5
MM3Z16VBW	16.	LZ	15.68	16	16.32	5	40	1	188	0.045	11.2
MM3Z18VBW	18.	MZ	17.64	18	18.36	5	45	1	212	0.045	12.6
MM3Z20VBW	20.	NZ	19.60	20	20.40	5	55	1	212	0.045	14.0

Small Outline Flat Lead Plastic Package Zener Voltage Regulators

Electrical Characteristics

T_A = 25°C unless otherwise noted

Device Type	Device Marking		V _Z @ I _{ZT} (Volts)			I _{ZT} (mA)	Z _{ZT} @ I _{ZT} (Ω) Max	I _{ZK} (mA)	Z _{ZK} @ I _{ZK} (Ω) Max	I _R @ V _R (μA) Max	V _R (Volts)
			Min	Nom	Max						
MM3Z22VBW	22.	PZ	21.56	22	22.44	5	55	1	235	0.045	15.4
MM3Z24VBW	24.	RZ	23.52	24	24.48	5	70	1	235	0.045	16.8
MM3Z27VBW	27.	SZ	26.46	27	27.54	5	80	0.5	282	0.045	18.9
MM3Z30VBW	30.	TZ	29.40	30	30.60	5	80	0.5	282	0.045	21.0
MM3Z33VBW	33.	UZ	32.34	33	33.66	5	80	0.5	306	0.045	23.0
MM3Z36VBW	36.	VZ	35.28	36	36.72	5	90	0.5	329	0.045	25.2
MM3Z39VBW	39.	WZ	38.22	39	39.78	5	130	0.5	329	0.045	27.3
MM3Z43VBW	43.	XZ	42.14	43	43.86	5	150	0.5	353	0.045	30.1
MM3Z47VBW	47.	YZ	46.06	47	47.94	5	170	0.5	353	0.045	33.0
MM3Z51VBW	51.	-Z	49.98	51	52.02	5	180	0.5	376	0.045	35.7
MM3Z56VBW	56.	=Z	54.88	56	57.12	5	200	0.5	400	0.045	39.2
MM3Z62VBW	62.	≡Z	60.76	62	63.24	5	215	0.5	423	0.045	43.4
MM3Z68VBW	68.	>Z	66.64	68	69.36	5	240	0.5	447	0.045	47.6
MM3Z75VBW	75.	<Z	73.50	75	76.50	5	255	0.5	470	0.045	52.5

V_F Forward Voltage = 1 V Maximum @ I_F = 10 mA for all types

Notes:

1. The Zener Voltage (V_Z) is tested under pulse condition of 10mS.
2. The device numbers listed have a standard tolerance on the nominal zener voltage of ±5%.
3. The zener impedance is derived from the 60-cycle ac voltage, which results when an ac current having an rms value equal to 10% of the dc zener current (I_{ZT} or I_{ZK}) is superimposed to I_{ZT} or I_{ZK}.

Rating and characteristic curves

FIG. 1-POWER DISSIPATION VS. AMBIENT TEMP.

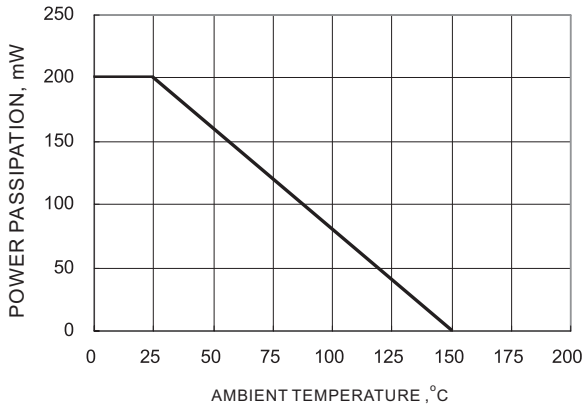

FIG. 2-EFFECT OF ZENER VOLTAGE ON ZENER IMPEDANCE

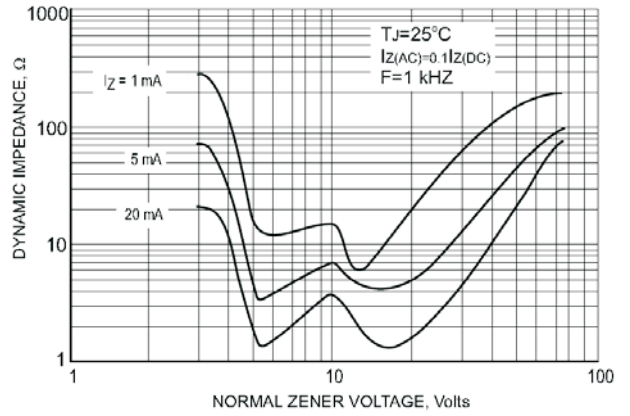

FIG. 3-TYPICAL FORWARD VOLTAGE

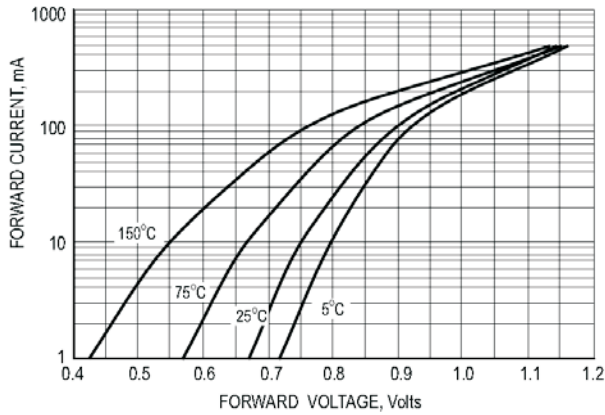

FIG. 4-TYPICAL CAPACITANCE

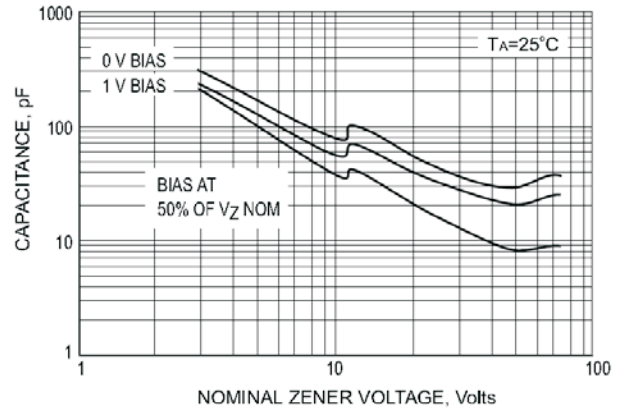

FIG. 5-ZENER BREAKDOWN CHARACTERISTICS

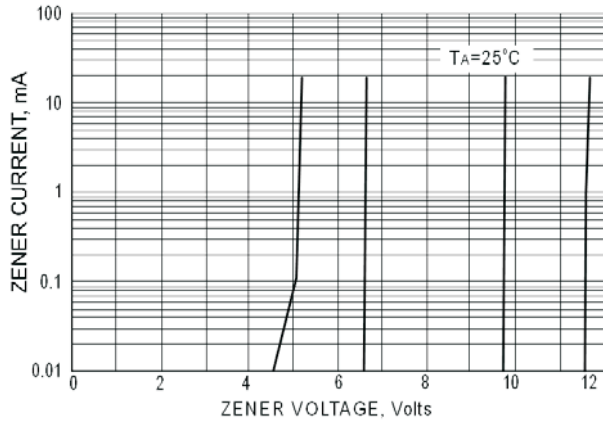
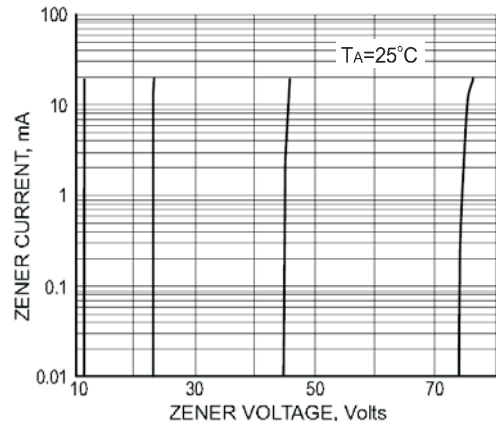
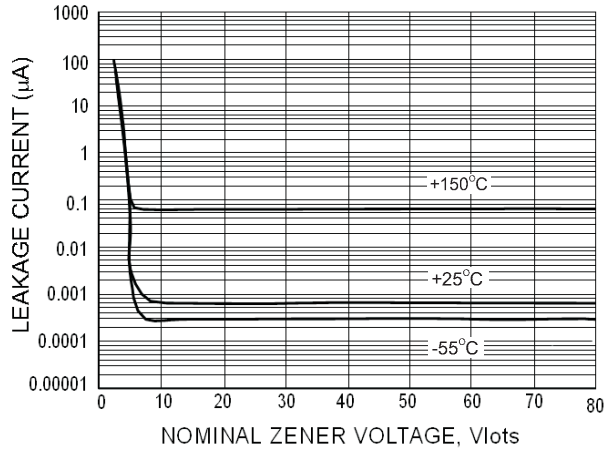

FIG. 6-ZENER BREAKDOWN CHARACTERISTICS



Rating and characteristic curves

FIG. 7-TYPICAL LEAKGE CURRENT



SOD-323 Package Outline

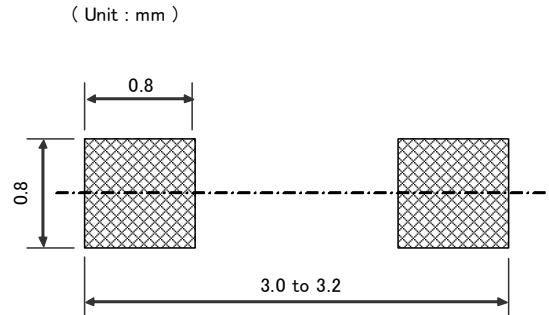
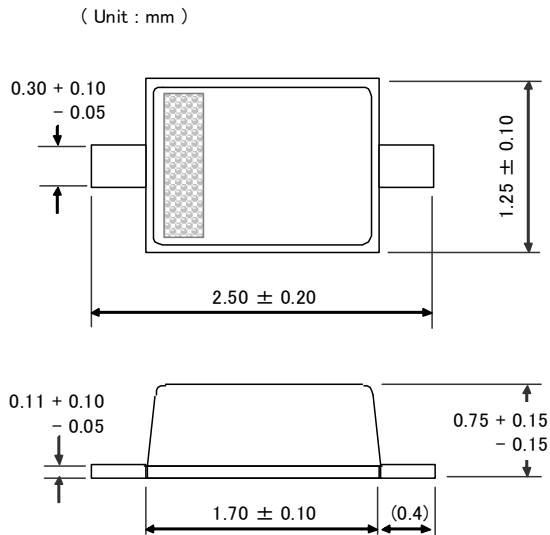

Land Pattern Recommendation

Notes:
 * Dimensions of POPPULA
 (JEDEC/JEITA: SOD-323/SC-90)

NOTES:
 1. The above package outline is similar to JEITA SC-90.