

P-Channel Enhancement Mode Field Effect Transistor

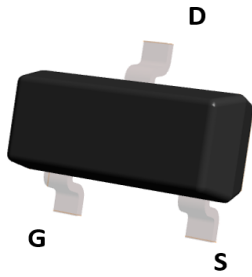

Top View

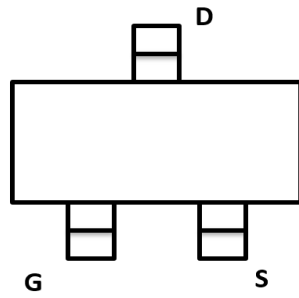

SOT-23-3L

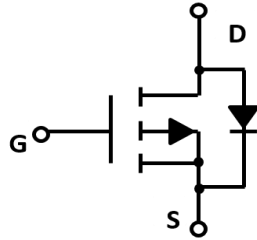

Product Summary

- V_{DS} -30V
- I_D -7.0A
- $R_{DS(ON)}$ (at $V_{GS}=-10V$) <25 mohm
- $R_{DS(ON)}$ (at $V_{GS}=-4.5V$) <36 mohm

General Description

- Trench Power LV MOSFET technology
- High density cell design for Low $R_{DS(ON)}$
- High Speed switching

Applications

- Battery protection
- Load switch
- Power management

■ Absolute Maximum Ratings ($T_A=25^\circ\text{C}$ unless otherwise noted)

Parameter	Symbol	Maximum	Unit
Drain-source Voltage	V_{DS}	-30	V
Gate-source Voltage	V_{GS}	± 20	V
Drain Current	I_D	$T_A=25^\circ\text{C}$ @ Steady State	-7.0
		$T_A=70^\circ\text{C}$ @ Steady State	-5.6
Pulsed Drain Current ^A	I_{DM}	-50	A
Total Power Dissipation @ $T_A=25^\circ\text{C}$	P_D	1.9	W
Thermal Resistance Junction-to-Ambient @ Steady State ^B	$R_{\theta JA}$	65.7	$^\circ\text{C}/\text{W}$
Junction and Storage Temperature Range	T_J, T_{STG}	-55~+150	$^\circ\text{C}$

■ Ordering Information (Example)

PREFERRED P/N	PACKING CODE	Marking	MINIMUM PACKAGE(pcs)	INNER BOX QUANTITY(pcs)	OUTER CARTON QUANTITY(pcs)	DELIVERY MODE
YJL07P03AL	F1	3007.	3000	30000	120000	7" reel



YJL07P03AL

■ Electrical Characteristics (T_J=25°C unless otherwise noted)

Parameter	Symbol	Conditions	Min	Typ	Max	Units
Static Parameter						
Drain-Source Breakdown Voltage	BV _{DSS}	V _{GS} =0V, I _D =-250μA	-30			V
Zero Gate Voltage Drain Current	I _{DSS}	V _{DS} =-30V, V _{GS} =0V, T _C =25°C			-1	μA
Gate-Body Leakage Current	I _{GSS}	V _{GS} = ±20V, V _{DS} =0V			±100	nA
Gate Threshold Voltage	V _{GS(th)}	V _{DS} = V _{GS} , I _D =-250μA	-1.0	-1.5	-2.5	V
Static Drain-Source On-Resistance	R _{DS(ON)}	V _{GS} = -10V, I _D =-7.0A		18.5	25	mΩ
		V _{GS} = -4.5V, I _D =-5.0A		24.5	36	
Diode Forward Voltage	V _{SD}	I _S =-7.0A, V _{GS} =0V		-0.8	-1.2	V
Maximum Body-Diode Continuous Current	I _S				-7.0	A
Dynamic Parameters						
Input Capacitance	C _{iss}	V _{DS} =-15V, V _{GS} =0V, f=1MHZ		1500		pF
Output Capacitance	C _{oss}			327		
Reverse Transfer Capacitance	C _{rss}			276		
Switching Parameters						
Total Gate Charge	Q _g	V _{GS} =-10V, V _{DS} =-15V, I _D =-7.0A		30		nC
Gate Source Charge	Q _{gs}			5.3		
Gate Drain Charge	Q _{gd}			7.6		
Turn-on Delay Time	t _{D(on)}	V _{GS} =-10V, V _{DS} =-15V, I _D =-4.2A, R _{GEN} =2.5Ω		14		ns
Turn-on Rise Time	t _r			20		
Turn-off Delay Time	t _{D(off)}			95		
Turn-off Fall Time	t _f			65		

A. Repetitive Rating: Pulse width limited by maximum junction temperature.

B. Surface Mounted on FR4 Board, t ≤ 10 sec.



■ Typical Performance Characteristics

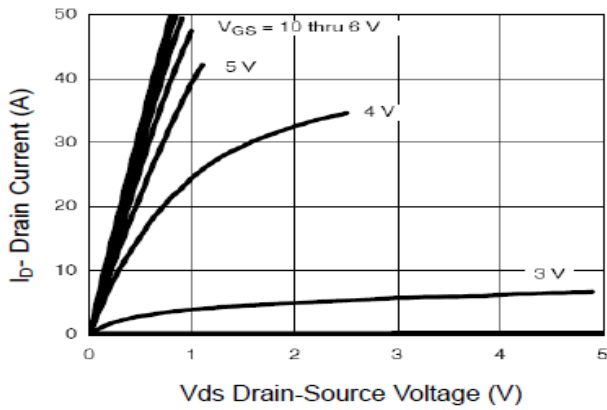

Figure1. Output Characteristics

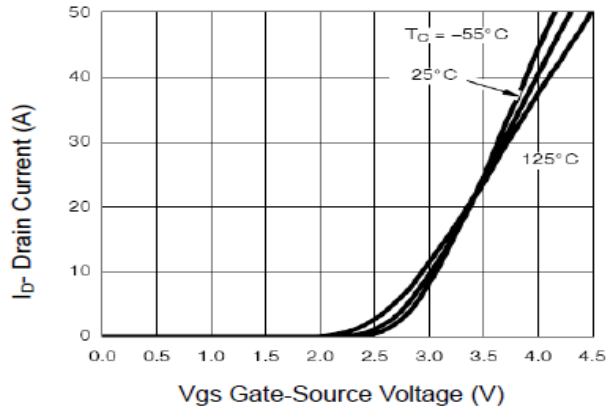

Figure2. Transfer Characteristics

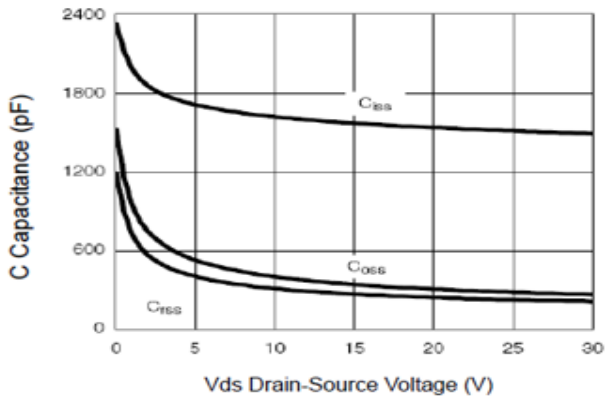

Figure3. Capacitance Characteristics

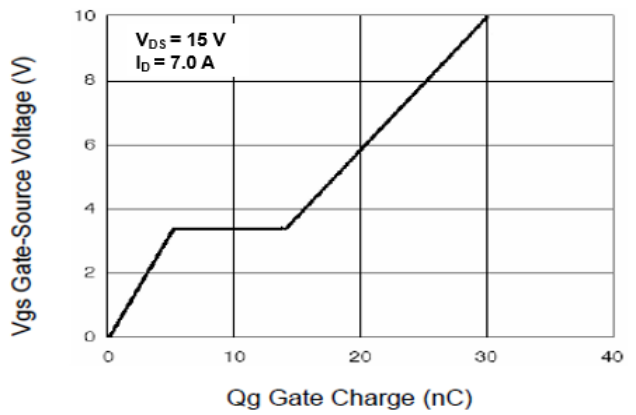

Figure4. Gate Charge

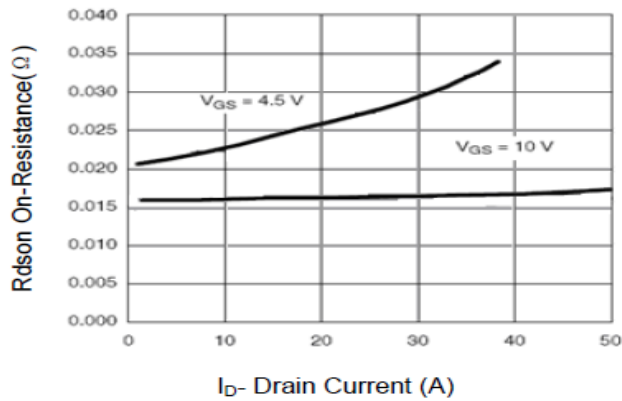

Figure5. Drain-Source on Resistance

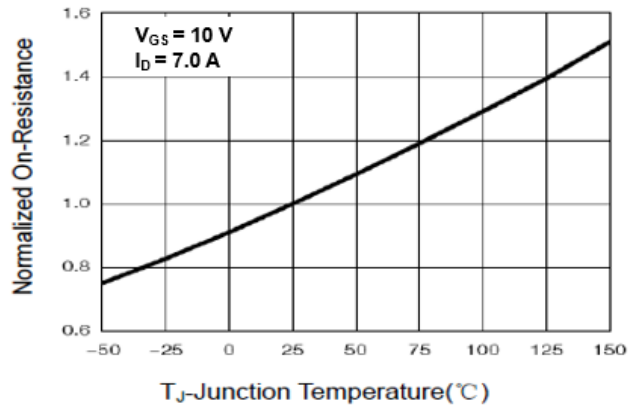

Figure6. Drain-Source on Resistance



YJL07P03AL

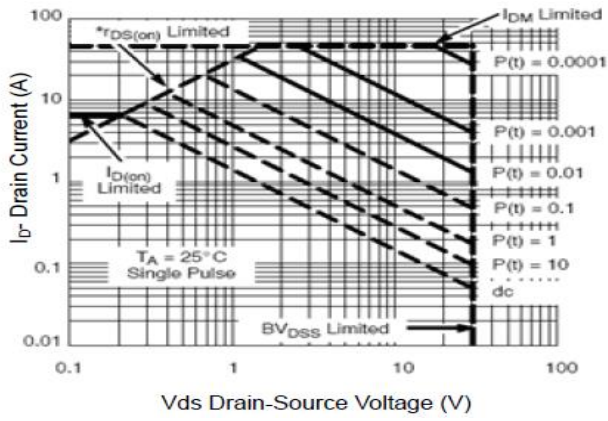

Figure7. Safe Operation Area

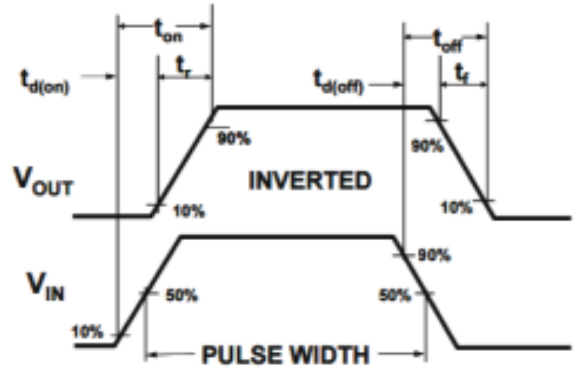
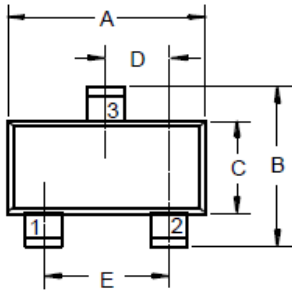

Figure8. Switching wave



■ SOT-23-3L Package information

SOT-23-3L



- 1. GATE
- 2. SOURCE
- 3. DRAIN

DIMENSIONS					
DIM	INCHES		MM		NOTE
	MIN	MAX	MIN	MAX	
A	.113	.117	2.87	2.97	
B	.108	.112	2.75	2.85	
C	.061	.065	1.55	1.65	
D	.036	.038	.914	.965	
E	.073	.077	1.85	1.95	
G	.0016	.0039	.04	.100	
H	.044	.049	1.12	1.25	
J	.006	.007	.14	.17	
K	.013	.015	.34	.37	

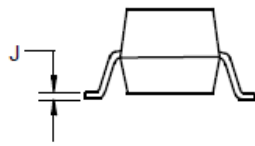
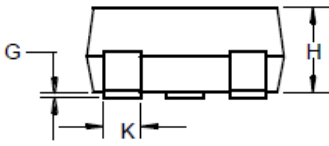

■ SOT-23-3L Suggested Pad Layout

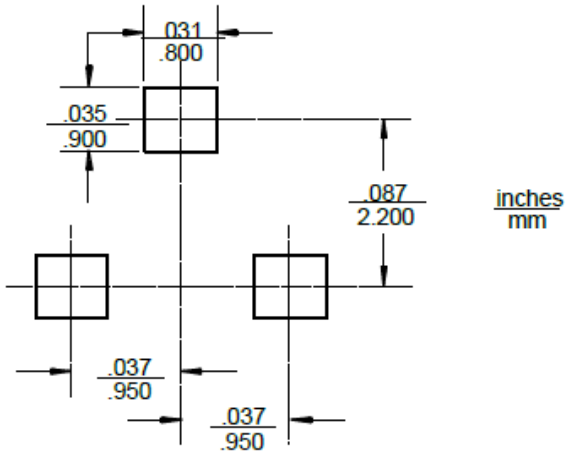



Disclaimer

The information presented in this document is for reference only. Yangzhou Yangjie Electronic Technology Co., Ltd. reserves the right to make changes without notice for the specification of the products displayed herein to improve reliability, function or design or otherwise.

The product listed herein is designed to be used with ordinary electronic equipment or devices, and not designed to be used with equipment or devices which require high level of reliability and the malfunction of which would directly endanger human life (such as medical instruments, transportation equipment, aerospace machinery, nuclear-reactor controllers, fuel controllers and other safety devices), Yangjie or anyone on its behalf, assumes no responsibility or liability for any damages resulting from such improper use of sale.

This publication supersedes & replaces all information previously supplied. For additional information, please visit our website [http:// www.21yangjie.com](http://www.21yangjie.com) , or consult your nearest Yangjie's sales office for further assistance.