

# SPECIFICATION FOR APPROVAL

CN: \_\_\_\_\_

CUSTOMER : \_\_\_\_\_

PRODUCT TYPE : SMD SEAM SEALING X'TAL 2.5 × 2.0

NOMINAL FREQ. : 27.120000MHz

TXC P/N : AZ27170001

REVISION : A1

CUSTOMER P/N : \_\_\_\_\_

PM / SALES : \_\_\_\_\_

DATE : \_\_\_\_\_

CUSTOMER CONFIRMATION : \_\_\_\_\_  
(Singnature)

\_\_\_\_\_ (Date)

- (1) TXC requires one copy returned with signature and title of authorized individual that signifies acceptance of the attached specifications.
- (2) Orders received and accepted by TXC after return of signed copy of specification will be produced per these specifications.
- (3) Any changes to these specifications must be agreed upon by both parties and new revision of the Product Specification Sheet will be issued.
- (4) Any issuance of purchase order prior to consigning back the Approval page of "Specification Sheets" from customers will be regarded as the agreement on the contents of these specifications.

**MSL:Level 1  
RoHS Compliant**

(for glass crystal only : Pb used with sealing glass material is exempt from EU directive)

# PRODUCT SPECIFICATION SHEET

CN: \_\_\_\_\_

PRODUCT TYPE : SMD SEAM SEALING X'TAL 2.5 × 2.0

---

NOMINAL FREQ. : 27.120000MHz

---

TXC P/N : AZ27170001

---

REVISION : A1

---

PE/RD	QA	MFG
<i>Minlin Tseng</i>	<i>Alex Huang</i>	<i>Rick Lo</i>
Minlin Tseng	Alex Huang	Rick Lo
4-Jul-17	4-Jul-17	4-Jul-17

**NOTE:**

- (1) TXC green product standard is based on the international standards. Relevant information is posted on the TXC website and updated regularly. The documentation is subject to the latest green product quality system.
- (2) Revision "Sx" is for engineering samples only. PE/RD's approval required.
- (3) Revision "Ax" is production ready. PE, QA and MFG's approval required.

**MSL:Level 1  
RoHS Compliant**

(for glass crystal only : Pb used with sealing glass material is exempt from EU directive)



## ■ ELECTRICAL SPECIFICATIONS

### Standard conditions

Ambient temperature :  $25 \pm 5^\circ\text{C}$

Relative humidity : 40%~70%

In addition to special specifications, are measured in the standard environment.

Ambient temperature :  $25 \pm 3^\circ\text{C}$

Relative humidity : 40%~70%

If there is any doubt about the result, it is necessary to make measurements in the standard environment.

### Measure equipment

Electrical characteristics measured by S&A 250B or equivalent.

### Crystal cutting type

The crystal is using AT CUT (thickness shear mode).

### Unit Weight:

0.009±0.001 g/pcs

	Parameters	Symbol	Electrical Spec.				Notes
			Min.	Typ.	Max.	Units	
1	Nominal Frequency	FL	27.120000			MHz	-
2	Oscillation Mode	-	Fundamental			-	-
3	Load Capacitance	CL	10			pF	-
4	Frequency Tolerance	-	$\pm 30$			ppm	at $25^\circ\text{C} \pm 3^\circ\text{C}$
5	Frequency Stability	-	$\pm 50$			ppm	Over Operating Temp. Range (Reference $25^\circ\text{C}$ )
6	Operating Temperature	-	-40	~	125	$^\circ\text{C}$	-
7	Aging	-	$\pm 3$			ppm	1st Year
8	Drive Level	DL	-	100	-	$\mu\text{W}$	-
9	Effective Resistance Rr	Rr	-	-	60	$\Omega$	-
10	Insulation Resistance	-	500	-	-	M $\Omega$	at DC 100V
11	Storage Temperature Range	-	-40	~	125	$^\circ\text{C}$	-

**■ DIMENSIONS**

(Unit:mm)

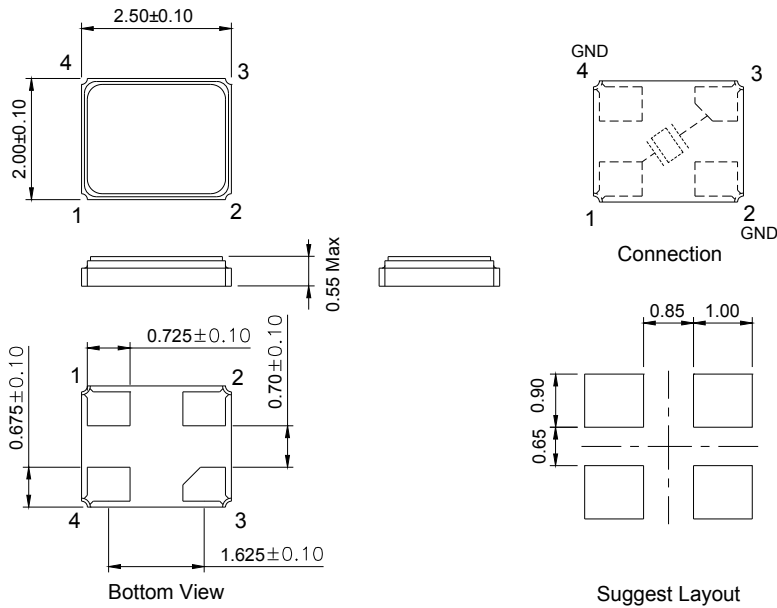

**■ MARKING**

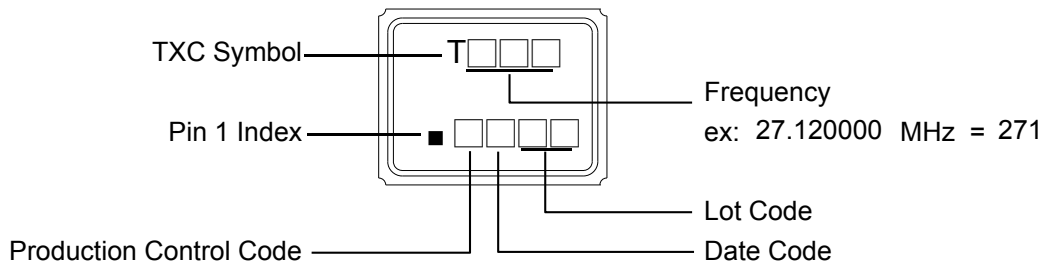

**Production location: Taiwan or China**

**■ SUGGESTED REFLOW PROFILE**

Peak Temperature :  $260 \pm 5^\circ\text{C}$ , 10 sec. Max.  
 Solder melting point :  $220 \pm 10^\circ\text{C}$ , 60 sec. Min.

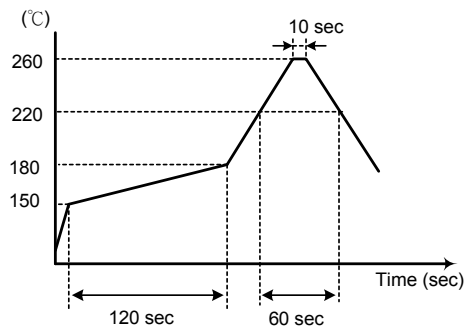

**■ SUGGESTED MANUAL SOLDER CONDITION**

Temperature:  $350 \pm 10^\circ\text{C}$   
 Time: 3 sec.  
 Re-solder times: twice

NOTE: After welding manually, the product should be placed at least 2 hours.

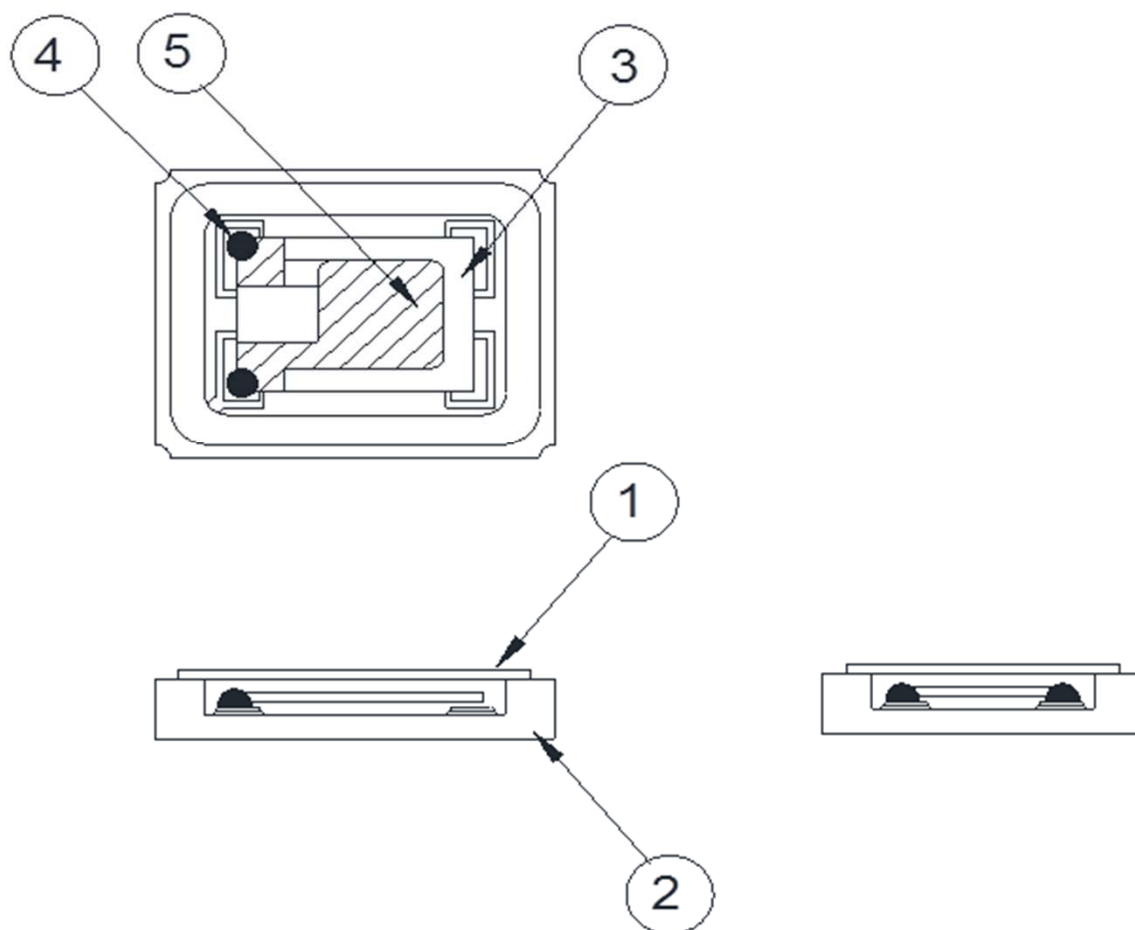
**■ STRUCTURE ILLUSTRATION**

NO	COMPONENTS	MATERIALS	FINISH/SPECIFICATIONS
1	Lid	Kovar	-
2	Base(Package)	Ceramic (Al <sub>2</sub> O <sub>3</sub> )+Pad(Au)	Alumina ceramics
3	Crystal blank	SiO <sub>2</sub>	-
4	Conductive adhesive	Ag	Silicone resin
5	Electrode	Noble Metal + Cr	-

■ PACKING

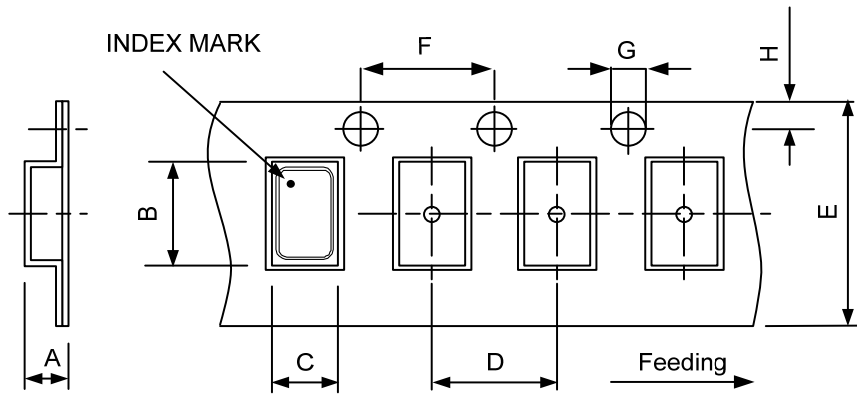

DIMENSIONS	A	B	C	D	E	F	G	H	(UNIT : mm)
	1.05	2.70	2.25	4.00	8.00	4.00	1.55	1.75	

REMARK :

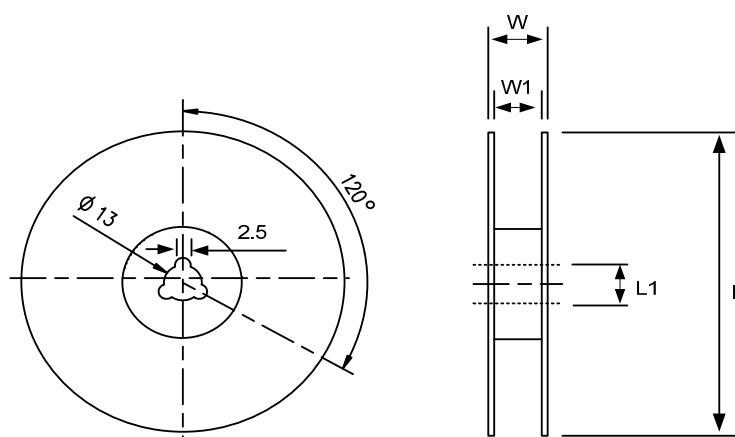
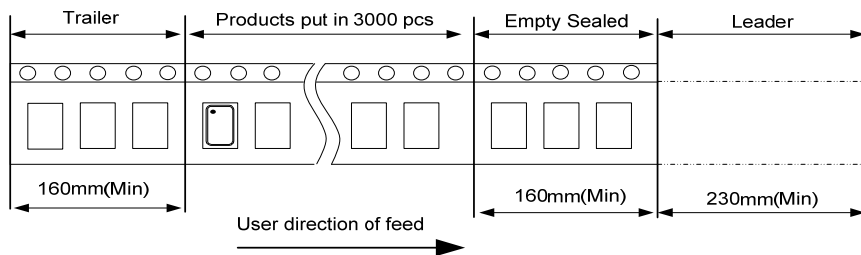

DIMENSIONS	L	L1	W	W1	pcs / Reel (UNIT : mm)
	178.0	13.0	11.5	8.0	Standard Reel Quantity is 3,000 pcs per reel

**RELIABILITY SPECIFICATIONS (AEC-Q200 Compliant)**

**1. Mechanical Endurance**

No.	Test Item	Test Methods	REF.DOC
1.1	Drop Test	120 cm height, 20 times on Stainless Plate .	JIS C 6701
1.2	Mechanical Shock	Device are shocked to half sine wave ( 5000 G ) three mutually perpendicular axes each 3 times. 0.3m sec. duration time	MIL-STD-202 Method 213
1.3	Vibration	Frequency range                    10 ~ 2000 Hz~10 Hz Amplitude                                1.52 mm/20G Sweep time                                20 minute Perpendicular axes each test time 4 Hrs (Total test time 12 Hrs)	MIL-STD-202 Method 204
1.4	Solderability	Temperature                            245 °C ± 5°C Immersing depth                        1.25 mm Immersion time                         5 ± 1 seconds Flux                                         Rosin resin methyl alcohol solvent ( 1 : 4 )	J-STD-002
1.5	Terminal Strength	Mount on PCB board and shear strength 1.8kg for 60 sec.	AEC-Q200-006
1.6	Board Flex	Duration Time: 60 sec, Deviation: 3mm	AEC-Q200-005

**2. Environmental Endurance**

No.	Test Item	Test Methods	REF. DOC
2.1	Resistance To Soldering Heat	Pre-heat temperature                125 °C Pre-heat time                            60 ~ 120 sec. Test temperature                        260 ± 5 °C Test time                                    10 ± 1 sec.	MIL-STD 202 Method 210
2.2	High Temp. Storage	+ 125 °C ± 3 °C for all 1000 Hrs.	MIL-STD-202 Method 108
2.3	Low Temp. Storage	- 40 °C ± 3 °C for all 1000 Hrs.	JIS C 6701
2.4	Thermal Shock	Total 1000 cycles of the following Thermal Shock : 	MIL-STD-202 Method 107
2.5	Temperature Cycle	Total 1000 cycles of the following temperature cycle : - 40°C ± 3 to 125°C ± 3 , Dwell time:15min.	JESD 22 Method JA-104
2.6	Biased Humidity	+ 85°C ± 3°C , RH 85% , 1000 Hrs.	MIL-STD-202 Method 103
2.7	Moisture Resistance	20 cycles ( +25°C~65°C , 80%~100% RH ) , 24hrs/cycle.	MIL-STD 202 Method 106
2.8	Operational Life	+ 125 °C ± 3 °C for 1000 Hrs.	MIL-STD-202 Method 108