

- SPECIFICATIONS:
- ELECTRICAL CHARACTERISTICS:
 - 1-1. CONTACT RESISTANCE: 30mΩ MAX.
 - 1-2. DIELECTRIC WITHSTANDING VOLTAGE: 100V AC FOR ONE MINUTE.
 - 1-3. INSULATION RESISTANCE: 100MΩ MIN. MEASURED BY 500 VDC
 - MECHANICAL CHARACTERISTICS:
 - 2-1. INSERTION FORCE :0.5-2.0Kgf(REF.)
 - 2-2. WITHDRAWAL FORCE :0.8-2.0Kgf(REF.)
 - LIFE TEST: 10,000 CYCLES.
 - TO CONFORM TO THE KRCDNN HAZARDOUS SUBSTANCE FREE SPEC.

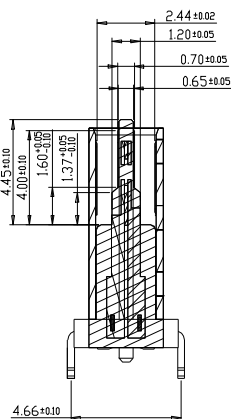

截面 1-1

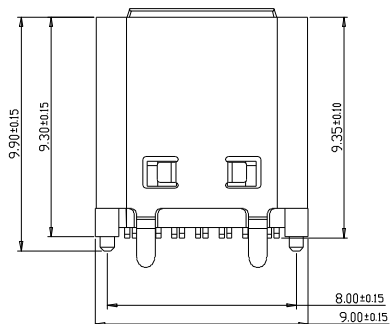
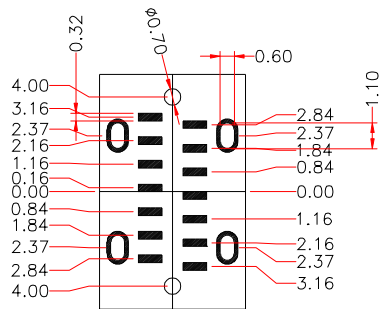

RECOMMENDED P.C.B. LAYOUT (T:1.00mm)
TOLERANCE UNSPECIFIED ±0.05mm

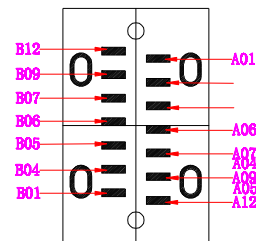

A1	GND	B12	GND
A4	VBUS	B9	VBUS
A5	CC1		
A6	DP1	B7	DN2
A7	DN1	B6	DP2
		B5	CC2
A9	VBUS	B4	VBUS
A12	GND	B1	GND
PIN	SIGNAL NAME	PIN	SIGNAL NAME

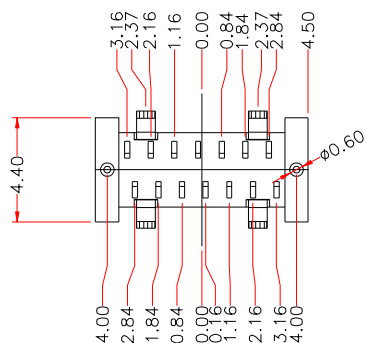

6	SHELL	STAINLESS STEEL	Ni Plated	IPCS
5	SHIELDING PLATE	STAINLESS STEEL	---	IPCS
4	MD	HIGH TEMPERATURE PLASTIC	BLACK	IPCS
3	CONTACT	COPPER ALLOY	Au/Ni Plated	ISET
2	CONTACT	COPPER ALLOY	Au/Ni Plated	ISET
1	HOUSING	HIGH TEMPERATURE PLASTIC	BLACK	IPCS
NO.	DESCRIPTION	MATERIAL	REMARKS	QTY

产品图
PRODUCT CHART DWG

公差一览表
TOLERANCE UNLESS OTHERWISE

X.	±0.30	X.	±5°
.X	±0.25	.X	±2°
.XX	±0.15	.XX	±1°
.XXX	±0.10	.XXX	±0.5°

深圳市精拓金电子有限公司

单位 UNITS	MM	制图 DRAWING	YANG	制图料号 PRODUCT PART NO.
比例 SCALE	1:1	审核 CHKD	郭志富	产品名称 PRODUCT NAME
日期 DATE	2019.11.23	核准 APPD	黄国荣	角法 VIEW
				版本 VER
				AD