

規格承認書

PECIFICATION FOR APPROVAL

客戶

CUSTOMER : 立創

項目

ITEM : 塑壳內磁喇叭

型號

TYPE : GSPK1335PN-8R0.7W-L100

描述

DESCRIPTION : Φ 13.0 x 3.5MM 單磁 8 Ω 0.7W UL1571/30#L100mm S.P.L: 90dB+/- 3dB

客戶料號

CUSTOMER NO. :

規格書號

SPECIFICATION NO.:

版本

EDITION NO. : V1.0

日期

DATE : 2020-7-21

客戶承認

CUSTOMER CONFIRM AND SIGN

檢查 TESTED BY	審核 CHECKED BY	承認 APPROVED BY

東莞市贏海電子有限公司

DONGUAN INGHAI ELECTRONICS CO.,LTD

製作 ISSUED BY	審查 CHECKED BY	確認 APPROVED BY
周明	刘承成	

地址：广东省东莞市长安镇上沙管理区新春1路新春科技园

電話 / TEL: 0769-83060958 傳真 / FAX: 0769-81608993

網址: [HTTP://WWW.INGHAI.COM](http://www.inghai.com)

DONGGUAN INGHAI ELECTRONICS CO.,LTD

Our Part No : GSPK1335PN-8R0.7W-L100

型号/PART No

该规格书适用于移动电话等使用的扬声器单元。

This Specification Applies to The Speaker, Used In Mobilephone sec.

A. 尺寸/TYPE

13mm圆形喇叭 电动式/ 13mm Rectangle Dynamic type

B. 尺寸与重量/DIMENSION

尺寸： 参考外观图面 (Figure.1)

Dimension: Refer To The Appearance Drawing. (Figure.1)

重量： $\pm 0.1g$

Weight: $\pm 0.1g$

C. 标准测试条件/STANDARD TEST CONDITION

在没有其他特别指定时，测试应如下所记的标准测试条件下进行。

Unless Otherwise Specified, The Test Shall Be Made Under The Standard Conditions.

- 温度/Temperature : $17^{\circ}C \sim 25^{\circ}C$ (Standard: $20.5^{\circ}C$)
- 相对湿度/Relative Humidity : $45\% \sim 85\%$ (Standare: 65%)
- 大气压力/Pressure : $86Kpa \sim 106Kpa$ (Standard: 101.3 Kpa)

D. 使用与储存温度/OPERATION AND STORAGE TEMIPERATURE

- 使用温度/Operation Temperature : $-40^{\circ}C \sim 85^{\circ}C$
- 储存温度/Storage Temperature : $-30^{\circ}C \sim 70^{\circ}C$

E. 电气特性规格/Electrical Specification

参考特性规格页面/Refer To The Appearance Page

F. 外观与尺寸：参考附图

Appearance&Dimensions: Refer To The Apprarence Drawtng (Figure.1)

G. 额定/Rated

项目/Items	规格/Specification	条件/Conditions
额定阻抗/Rated Impeance	$8\Omega \pm 20\%$	at 1kHz 100 mV
额定输入功率/Rated input power	0.7W	

最大输入功率/Max input power	1.0W	
最低共振频率 /Resonant Frequency	650±20% Hz	1V Input
灵敏度/Sound pressure level	90dB±3dB at 1KHz (0dB SPL=20μPa)	SPL at 1.0kHz in Average (0dB SPL=20μPa) Measuring condition: 0.5W (Sine wave) 0.1m measured with baffler shown in Figure3
有效频率范围 /Frequency response	200~5000Hz	
总谐波失真/THD	≤5% at 1kHz	at 1kHz 0.1W

H. 动作检查/OPERATIONAL TEST

项目/ITEM	信号/SIGNAL	输入/INPUT	扫频范围/SWEEP RANGE
SWEEP TEST	Sine Wave	0.8W (2.43V)	200~5000Hz

- 在动作检查中不得有异常音出现
- Without Abnormal Sound In Operation Test.

I. 负荷实验/LOAD TEST

项目/ITEM	信号/SIGNAL	I 输入/INPUT	驱动时间 DRIVING TERM
Continuous load Test	With Noise/Jis Filter (Refer To Jis C5531)	0.7W (2.43V) (RMS)	96hours (with 5cc test box)

- 在负荷实验 后不得有异常音出现,灵敏度应保持在限度范围内。
- Without Abnormal Sound After Test, And The S.P.L Shall Be In The Limit.
- 负荷实验应使用粉红噪声信号
- Running Test Shall Use pink Noise Signal

J. 可靠性实验/Reliability Test

项目/Item	规格/Specification	判定/Judgement
高温放置实验 Hightemp.Storage Test	85℃±2℃/20~40%RH/96HR & 20℃±5℃,1H	实验完成后产品应满足上述第 H, I, J 项要求。 Clause H, I, J Shall be Satisfied After Test
低温放置实验 Lowtemp.Storage Test	-40±2℃/20~40%RH/96HR & 20℃±5℃,1H	
耐湿实验 Humidity Test	40℃±2℃/90~95%RH/96HR & 20℃±5℃,1H	
耐高温负荷实验 Heatrunning Test	85℃±2℃/20~40%RH/-	
耐低温负荷实验 Coldrunning Test	-40℃±2℃/20~40%RH/-	
热冲击实验 Thermalshock Test	+85℃±2℃—30℃±2℃—+85℃±2℃ 5Cycles	
震动实验 Vibration Test	10Hz—40Hz—10Hz/60s, 1.0mm (X: 2H, Y: 2B)	

K. 跌落实验/SHOCK TEST

项目/Item	条件/Condition	判定/Judgement
Drop Test	产品在包装状态下,从 1 米高处向混凝土地面跌落:1角:1次:3边:每条边1次:6面:每 1 面 1 次 Speaker Shall Be Packed In The Carton And Dropped The Concrete Floor(H:1m)	实验完成后新产品应满足上述第 I 项要求 Clause I Shallbe Satisfied Afier Test

L. Product Size

线长可定制 L50mm

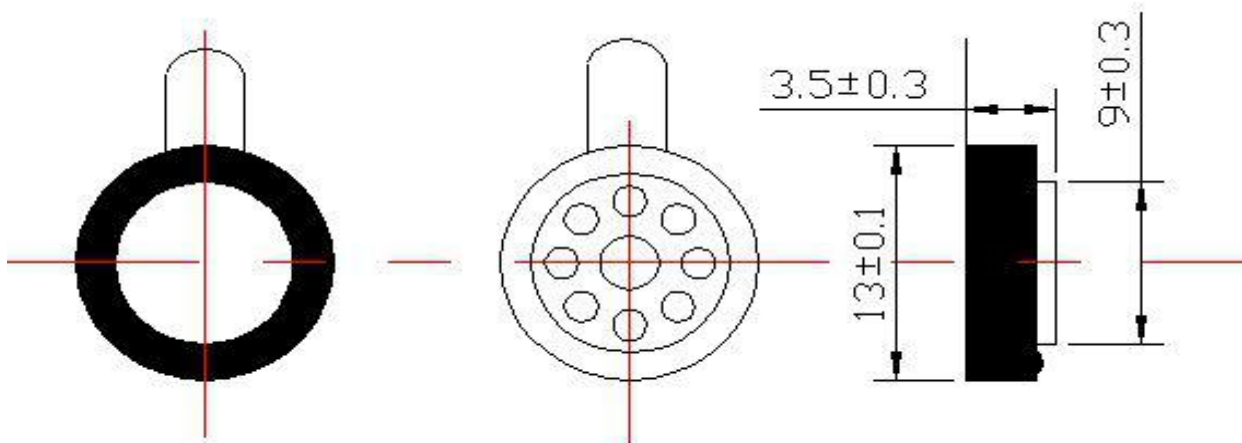

Figure.1

ITEM	DESCRIPTIONS	SPEC.	SUPPLIER	QTY	REMARK
1	Front foam ring	Adhesive		1	
2	Front cover	1Cr18Ni9		1	
3	Diaphragm	PEN		1	
4	Voice coil	Self-bonding wire		1	
5	Inner pole shoe	08F,		1	
6	Magnet	Nd-Fe-B		1	
7	U YOKE	SPCE		1	
8	PCB	T0.3		1	
9	Lead wire	UL1571 AWG32#		2	
10	Yoke assembly	PBT, black		1	
11	Insulator pad	Mylar		0	

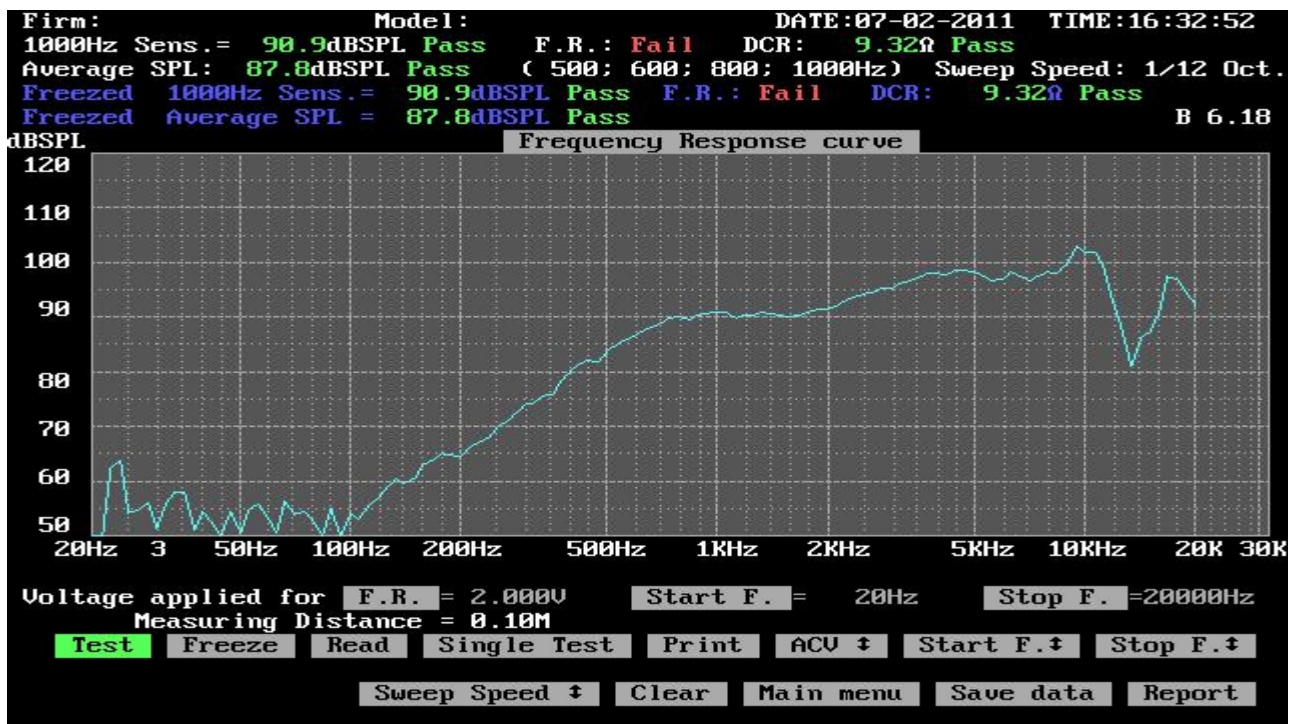
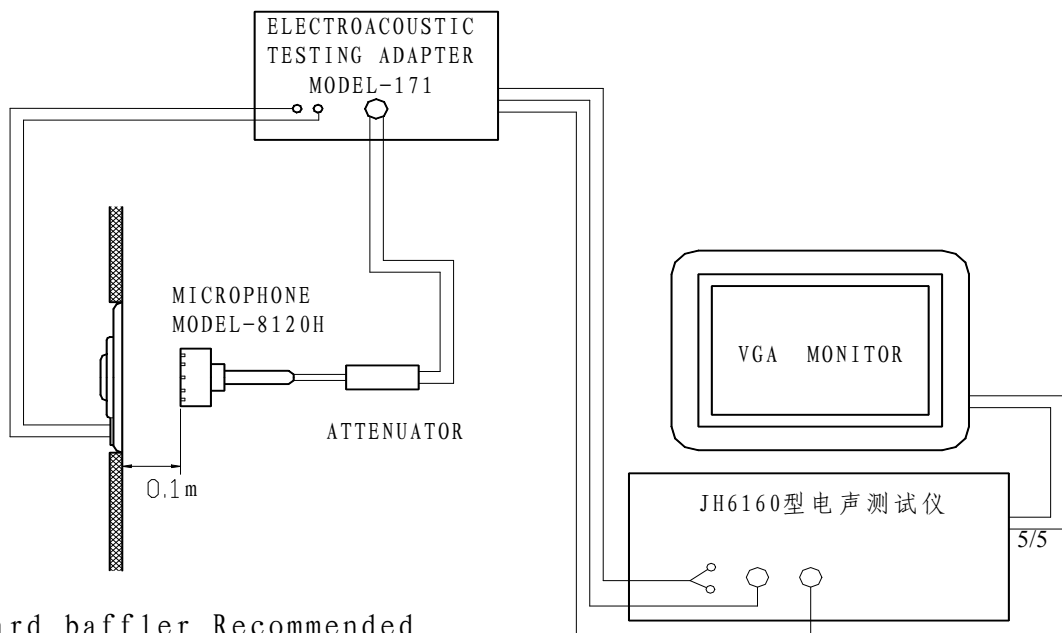

Figure.2

FREQUENCY MEASURING CIRCUIT AND EAR PIECE



Standard baffle Recommended
 In IEC 268 where 491mm(W) × 600mm(H)

Figure.3