

ACAD GENERATED DRAWING. DON'T CHANGE BY HAND

1.25mm PITCH WIRE TO BOARD CONNECTOR

REV	DATE	ECN NO.	MODIFICATION	APPROVER
B	2010/12/17	RD00310121701	版本升级	HYQ

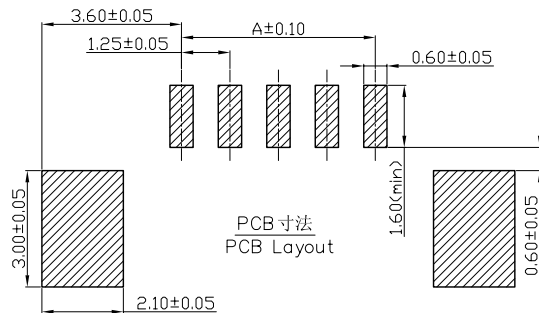
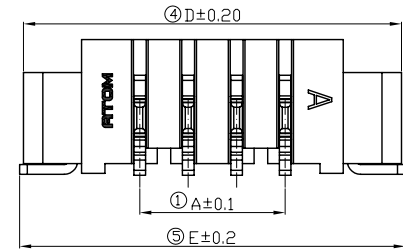
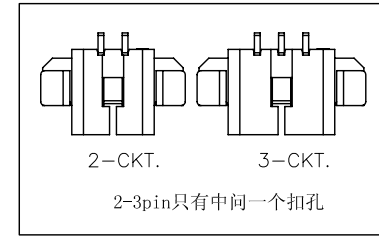
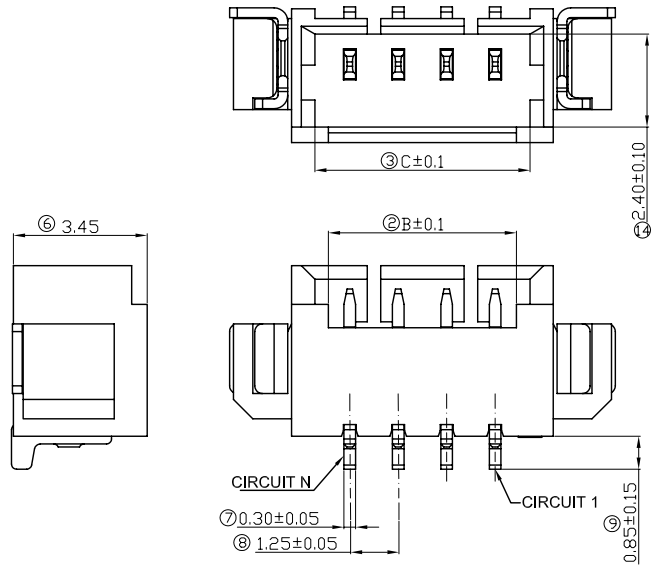

SPECIFICATION

- Material:
 - Housing: Thermoplastic, UL94V-0,color:Natural .
 - Contacts: copper alloy.
 - Tin/Gold plated over nickel plated
 - Solder tab: copper alloy.
 - Tin/Gold plated over nickel plated
- Electrical Characteristics:
 - Voltage rating: 125V(rms).
 - Current rating :1A(max).
 - Operating Temperature: -25°C~+85°C.
 - Storage Temperature: -5°C~+35°C. 70%R.H.MAX.(No condensation)
 - Insulation resistance: 1000M ohms min. at 500VDC
 - Dielectric withstanding voltage: 500 VAC/1minute.
 - Contact resistance: 30m ohms max.

孔位	A	B	C	D	E
2	1.25	2.35	3.05	7.25	7.45
3	2.50	3.60	4.30	8.50	8.70
4	3.75	4.85	5.55	9.75	9.95
5	5.00	6.10	6.80	11.00	11.20
6	6.25	7.35	8.05	12.25	12.45
7	7.50	8.60	9.30	13.50	13.70
8	8.75	9.85	10.55	14.75	14.95
9	10.00	11.10	11.80	16.00	16.20
10	11.25	12.35	13.05	17.25	17.45
11	12.50	13.60	14.30	18.50	18.70
12	13.75	14.85	15.55	19.75	19.95
13	15.00	16.10	16.80	21.00	21.20
14	16.25	17.35	18.05	22.25	22.45
15	17.50	18.60	19.30	23.50	23.70
16	18.75	19.85	20.55	24.75	24.95
17	20.00	21.10	21.80	26.00	26.20
18	21.25	22.35	23.05	27.25	27.45
19	22.50	23.60	24.30	28.50	28.70
20	23.75	24.85	25.55	29.75	29.95

GENERAL TOLERANCE	UNITS mm	NAME: 1.25mm W-T0-B CONN. (卧贴式)	深圳市爱特姆科技有限公司 SHENZHEN ATOM TECHNOLOGY CO.,LTD.		
SELECT <input checked="" type="checkbox"/>	MAT'L	PART NO: WF125***-01***	TITLE: Customer Drawing For 1.25mm W-T0-B CONN. (卧贴式)		
DN. TOL 1 2 3	FINISH	APPD: hyq	DWG NO. ATOM-A01467		
X.XXX ±0.10 ±0.05 ±0.15	Q'TY	CHKD: Vicky	SCALE SHEET REV 1:1 1/1 B		
X.XX ±0.15 ±0.13 ±0.25	DR: Linda				
X.X ±0.20 ±0.25 ±0.5					
X. ±0.30 ±0.38 ±1.00					
ANGLE ±2°					