

WD1601

40V,500mA,Step-Down DC/DC Converter

[Http://:www.sh-willsemi.com](http://www.sh-willsemi.com)

Descriptions

The WD1601 is a high efficiency synchronous step down DC-DC converter with integrated internal high-side and low-side high voltage power MOSFETs. It delivers 500mA of continuous output current with operating at an input range of 5V-40V. The internal synchronous power switches provide high efficiency without the use of an external Schottky diode.

The WD1601 operates at 800KHz fixed switching frequency with Pulse-Width-Modulation (PWM) and enters Pulse-Skipping-Modulation (PSM) operation at light load current to maintain high efficiency and low output ripple over the entire load current range. The WD1601 has short-circuit protection, thermal protection, and input under voltage and over voltage lockout.

The WD1601 is available in SOT-23-6L package. Standard products is Pb-Free and Halogen-Free.

Features

- Wide 5V~40V Operating Input Range
- Typical 800kHz Switching Frequency
- 500mA continuous output current
- 2uA Shutdown Current
- > 97% Efficiency
- 0.8V Feedback reference voltage
- 0.59Ω Internal Power HS MOSFET Switch
- 0.21Ω Internal Synchronous LS MOSFET Switch
- Cycle-by-Cycle Over Current Protection
- Internal Soft-Start
- RoHS Compliant

Applications

- Smart Meters
- Automotive Systems
- Distributed Power Systems
- Industrial Applications



SOT-23-6L

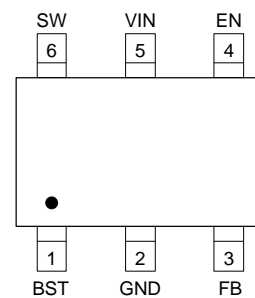

SOT-23-6L

Pin configuration (Top view)

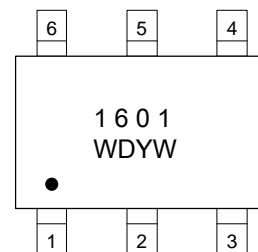

SOT-23-6L

1601 = Device code
WD = Special code
Y = Year code
W = Week code
Marking

Order information

Device	Package	Shipping
WD1601E-6/TR	SOT-23-6L	3000/Reel&Tape

Typical applications

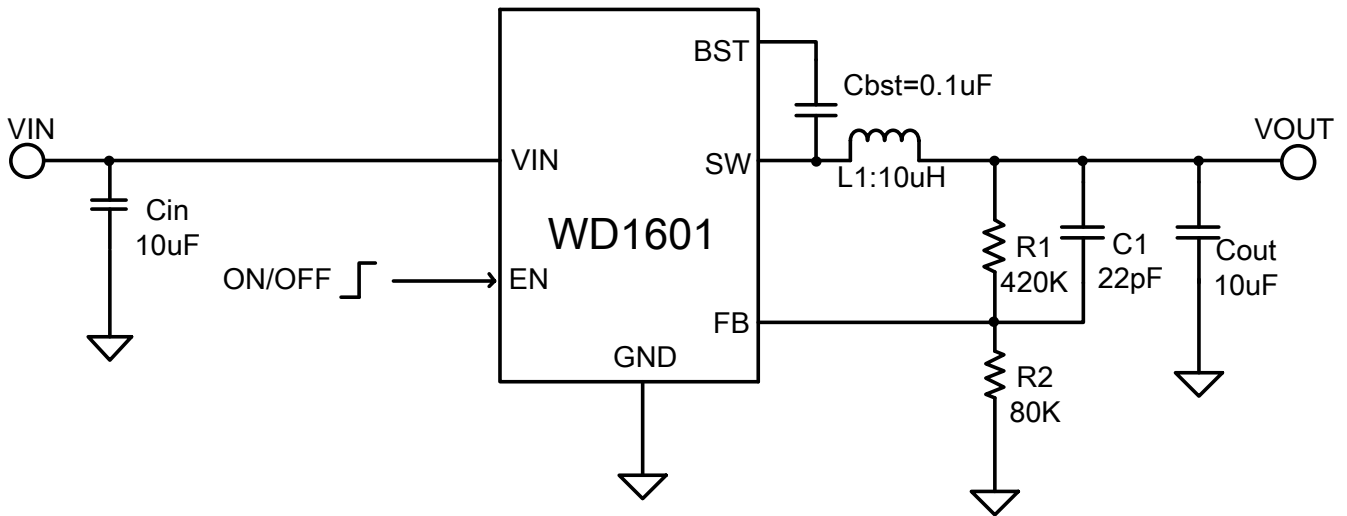

Pin descriptions

Symbol	Pin Number	Descriptions
BST	1	Bootstrap. A 100nF capacitor is connected between SW and BST pins to drive the power switch's gate above the supply voltage.
GND	2	Ground. This pin is the voltage reference for the regulated output voltage. For this reason care must be taken in its layout.
FB	3	Feedback. An external resistor divider from the output to GND, tapped to the FB pin sets the output voltage.
EN	4	On/Off Control Input. Do not leave it floating.
VIN	5	Power Supply Input. Connecting a ceramic bypass capacitor between VIN and GND to eliminate noise.
SW	6	Switch Output. Connect this pin to the switching end of the inductor.

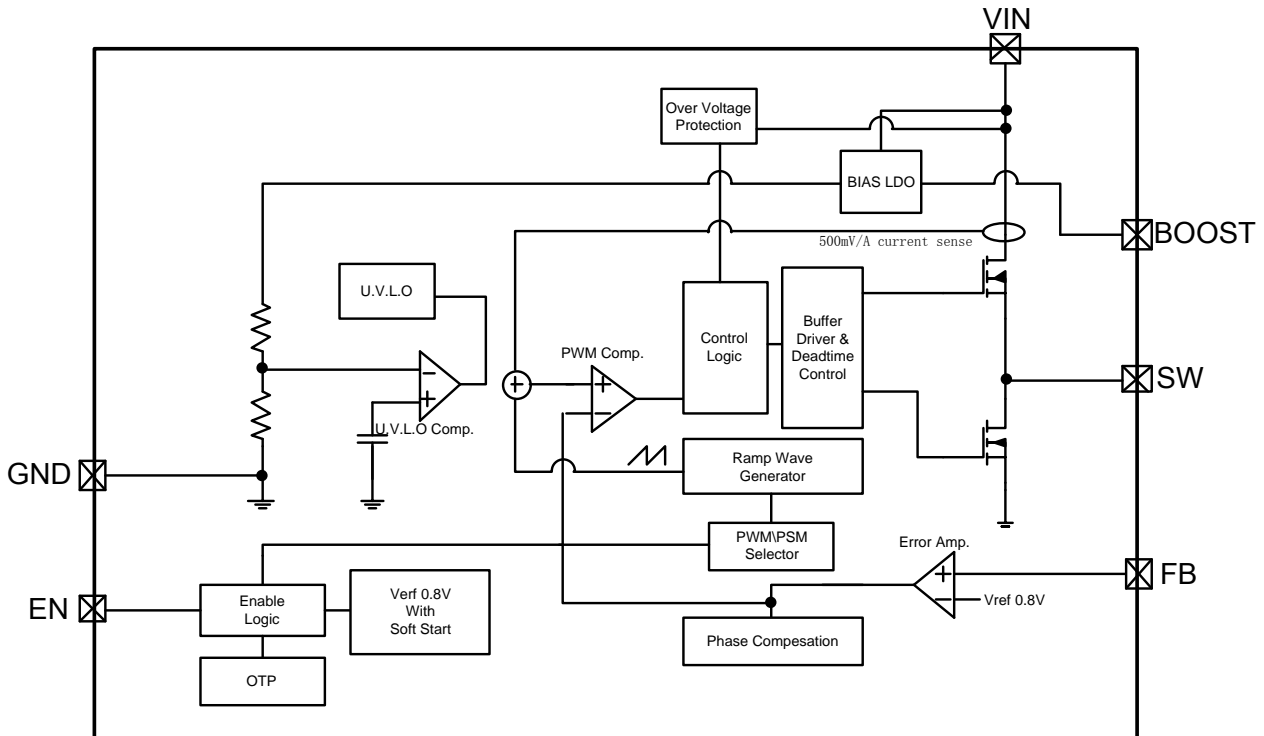
Block diagram

Absolute maximum ratings

Parameter	Symbol	Value	Unit
VIN pin voltage range	V_{IN}	-0.3~+45	V
EN pin voltage range	-	-0.3~ V_{IN}	V
SW pin voltage range (DC)	V_{SW}	-0.3~($V_{IN(Max)}+0.3$)	V
BST pin voltage range(DC)		($V_{SW} - 0.3$) ~ ($V_{SW} + 6$)	V
All Other Pins Voltage	-	-0.3~ 6	V
Power Dissipation – SOT23-6L (Note 1)	P_D	0.5	W
Thermal Characteristics (Note 1)	$R_{\theta JA}$	250	°C/W
	$R_{\theta JC}$	110	°C/W
Maximum Junction Temperature	T_J	150	°C
Lead temperature(Soldering, 10s)	T_L	260	°C
Operating ambient temperature	T_{opr}	-40 ~ 85	°C
Storage temperature	T_{stg}	-55 ~ 150	°C
ESD Classification	HBM	3500	V
	MM	300	V

These are stress ratings only. Stresses exceeding the range specified under “Absolute Maximum Ratings” may cause substantial damage to the device. Functional operation of this device at other conditions beyond those listed in the specification is not implied and prolonged exposure to extreme conditions may affect device reliability.

Note 1: Surface mounted on FR-4 Board using 1 square inch pad size, dual side, 1oz copper

Electronics Characteristics

(Ta=25°C, VIN=12V, VEN=2V, unless otherwise noted)

Parameter	Symbol	Conditions	Min.	Typ.	Max.	Units
Input Voltage Range	V _{IN}		5		40	V
V _{IN} Under Voltage Lockout Threshold	V _{UVLO}	Rising		4.55		V
		Falling		4.3		
Standby Supply Current	I _Q	V _{FB} = 105%, I _{OUT} = 0A		45		μA
Shutdown Supply Current	I _{SHDN}	V _{EN} = 0V, V _{in} =12V		2		μA
Feedback reference Voltage	V _{FB}		0.78	0.8	0.82	V
Line Regulation	Δ _{LINE}	V _{IN} = 5V to 40V		0.02		%/V
Load Regulation	Δ _{LOAD}	I _{OUT} = 100mA to 0.5A		±0.1		%/A
Inductor Peak Current Limit	I _{LIM}	V _{IN} = 12V, V _{OUT} = 5V		1.1		A
Oscillator Frequency	f _{OSC}	V _{FB} or V _{OUT} in regulation		800		kHz
R _{DS(ON)} of HS	R _{HS}	I _{SW} = -100mA		0.60		Ω
R _{DS(ON)} of LS	R _{LS}	I _{SW} = 100mA		0.21		Ω
Feedback Leakage Current	I _{FB}	V _{FB} =0.85V			±30	nA
SW Leakage Current	I _{LSW}	V _{IN} = 12V, V _{SW} = 0V or 12V			±1	μA
EN Rising Threshold	V _{ENH}		1.59	1.80	1.91	V
EN Falling Threshold	V _{ENL}		1.395	1.55	1.705	V
EN Leakage Current	I _{EN}	V _{IN} = 12V, V _{EN} = 0V			1	μA
		V _{IN} = 12V, V _{EN} = V _{IN}		1	2	
Min On Time	T _{ON-MIN}			100		nS
Max Duty Cycle	D _{MAX}			99.5		%
Soft Start Time	SS			700		μS
Input OVP Shutdown	V _{OVP}	Rising		42.5		V
		Falling	40	41.5		V
Over Voltage Protection Blanking Time	T _{Blanking}			15		μS
Over Temperature Protection	T _{OTP}			155		°C
OTP Hysteresis				30		°C

Typical Characteristics

($T_a=25^{\circ}\text{C}$, $V_{IN}=12\text{V}$, $V_{EN}=3.6\text{V}$, $V_{OUT}=3.3\text{V}$, $L=10\mu\text{H}$, $C_{IN}=10\mu\text{F}$, $C_{OUT}=10\mu\text{F}$, $C_1=22\text{pF}$, unless otherwise noted)

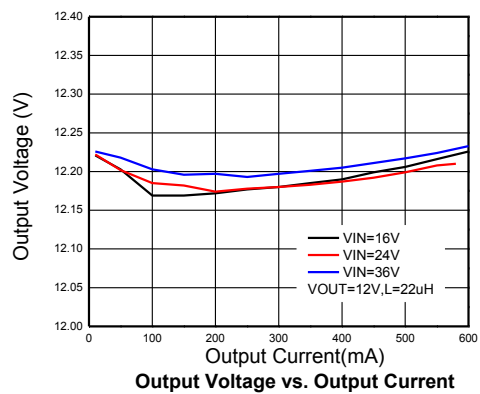
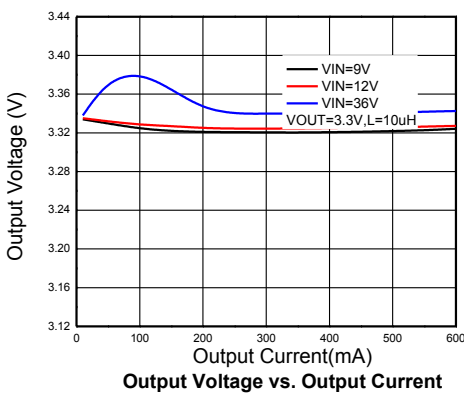
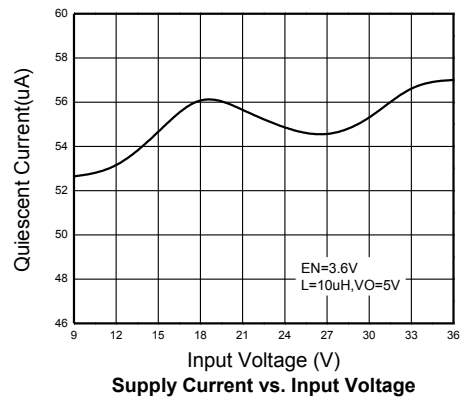
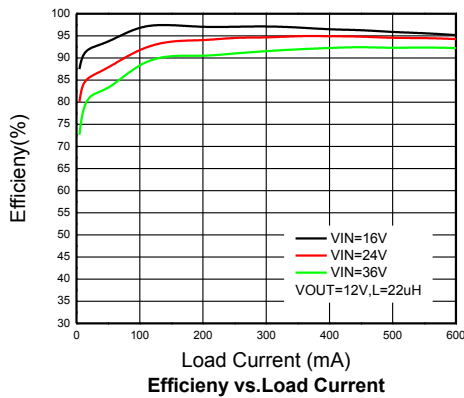
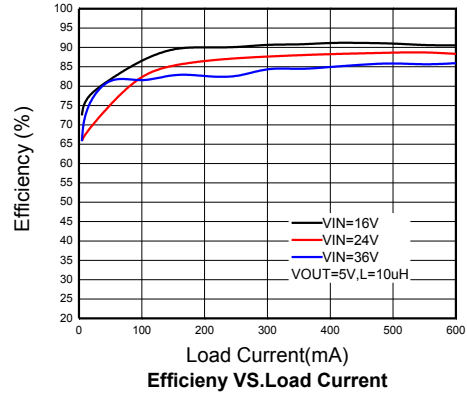
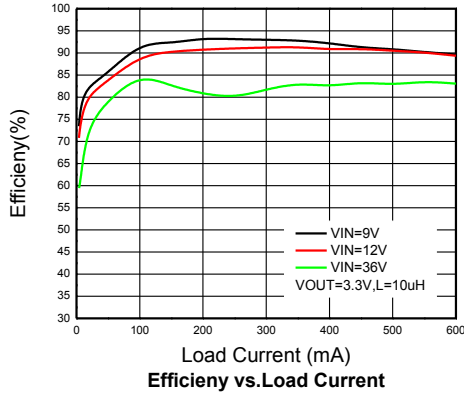

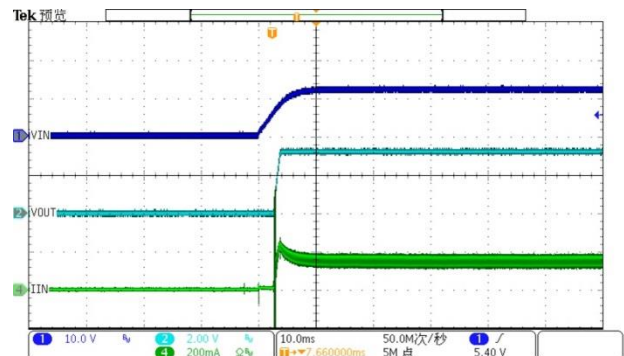
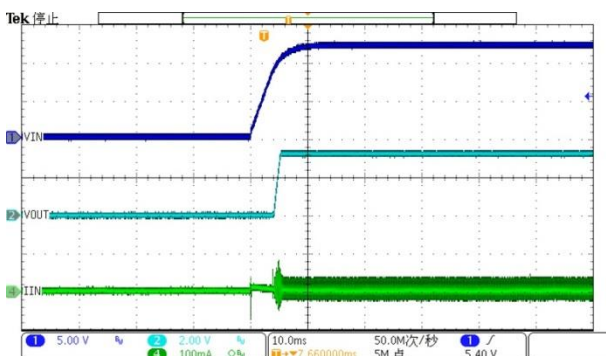
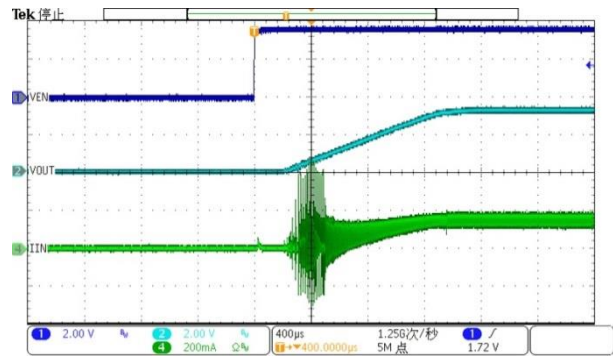
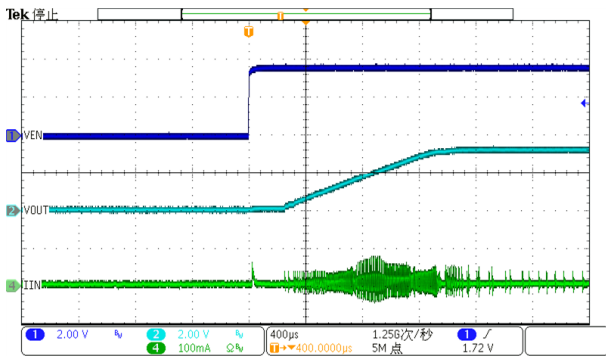
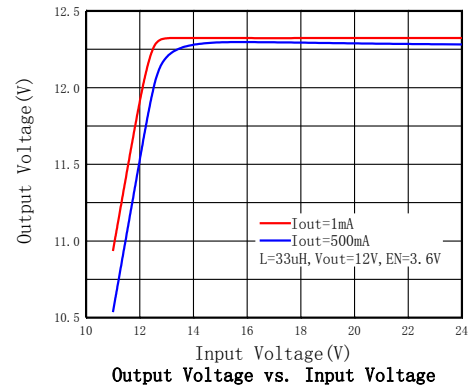
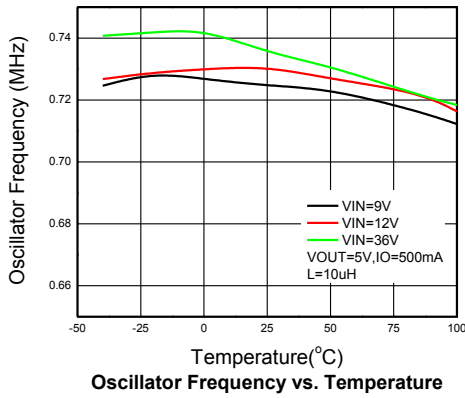

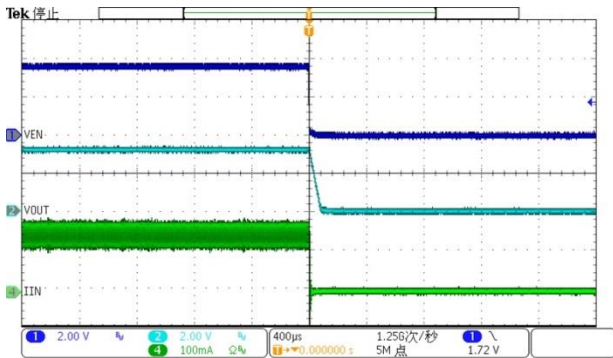
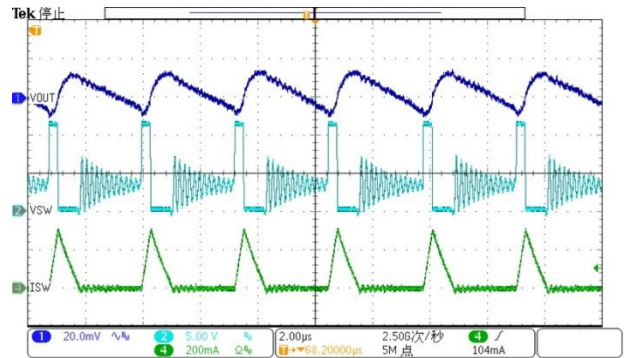
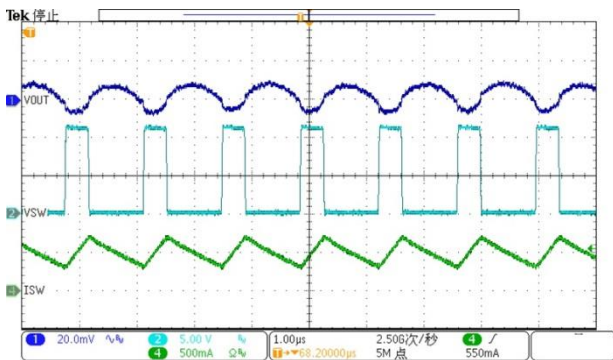
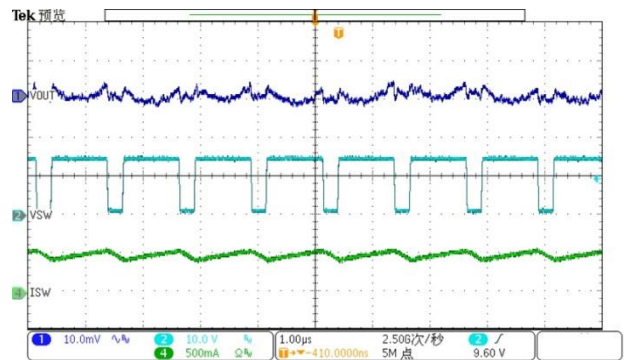
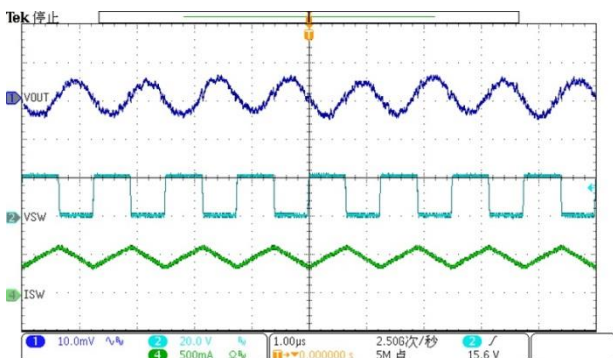
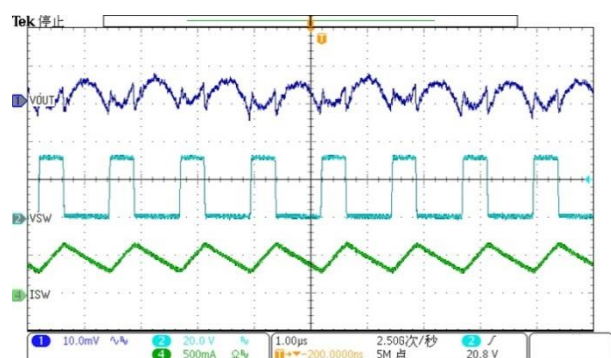

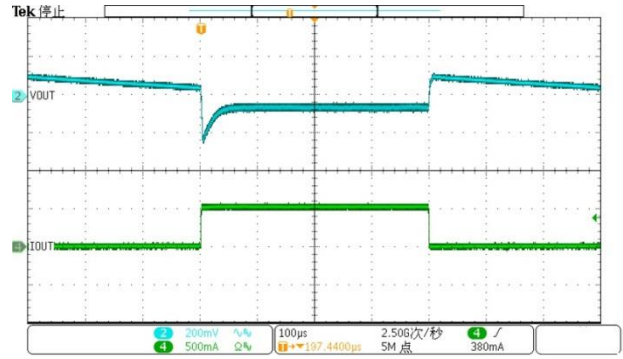
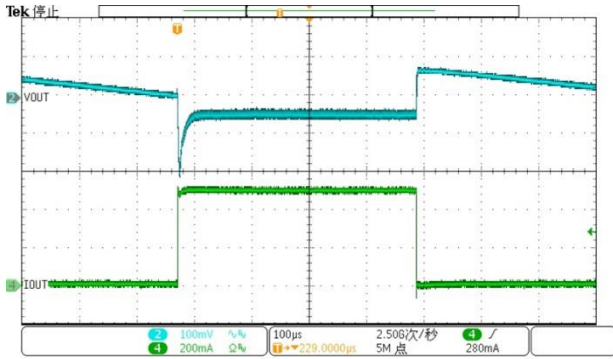
VIN=12V,VO=3.3V,EN=3.6V,IO=500mA, EN Off

Ripple,VIN=12V,VO=3.3V,EN=3.6V,IO=50mA

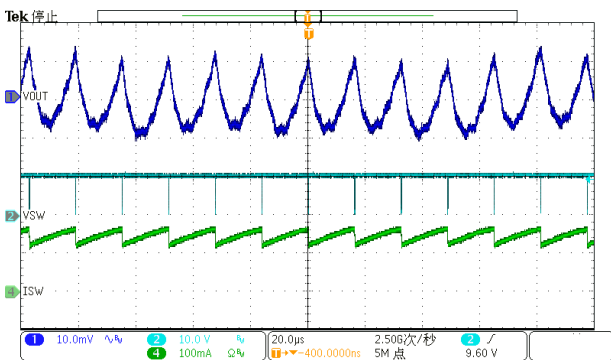
Ripple,VIN=12V,VO=3.3V,EN=3.6V,IO=500mA

Ripple, VIN=16V,VO=12V,IO=500mA,L=33uH

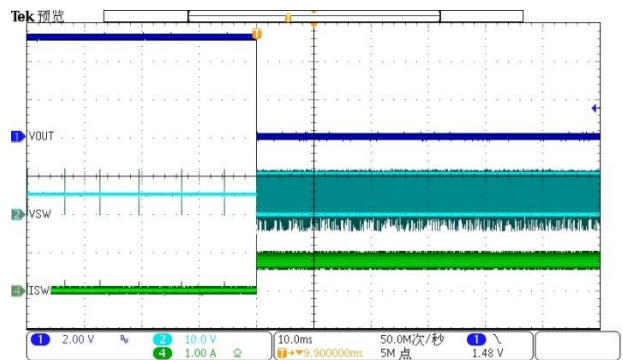
Ripple,VIN=24V,VO=12V, IO=500mA,L=33uH

Ripple,VIN=36V,VO=12V, IO=500mA,L=33uH



Load Transient Response, VO=3.3V, IO=1mA-500mA Load Transient Response, VO=5V, IO=1mA-500mA



DropOut Waveform, VO=12V, L=33µH, IO=150mA



Short-Circuit Response, VO=5V

Operation Informations

Control Mode

The WD1601 step-down converter operates with typically 0.8MHz fixed-frequency pulse width modulation (PWM) at moderate to heavy load currents. Both the upper and lower synchronous N-channel MOSFET switches are internal. During PWM operation, the converter uses a current-mode control scheme to achieve good line and load transient response. At the beginning of each clock cycle initiated by the clock signal, the main switch is turned on. The current flows from the input capacitor via the main switch through the inductor to the output capacitor and load. During this phase, the current ramps up until the PWM comparator trips and the control logic turn off the switch. After a dead time, which prevents shoot-through current, the synchronous switch is turned on and the inductor current ramps down. The current flows from the inductor and the output capacitor to the load. It returns back to the inductor through the synchronous switch.

The next cycle is initiated by the clock signal again turning off the synchronous switch and turning on the main switch.

At light loads, the inductor current may reach zero or reverse on each pulse. The synchronous switch is turned off by the current reversal comparator, I_{RCMP} , and the switch voltage will ring. This is discontinuous mode operation, and is normal behavior for the switching regulator. At very light loads, the WD1601 will automatically skip pulses in pulse skipping mode (PSM) operation to maintain output regulation.

Short-Circuit Protection

When the output is shorted to ground, the device goes into shutdown. In this mode, the high-side and low-side MOSFET are turned off.

Dropout Operation

Once the input voltage comes close to the nominal

output voltage, the upper switch is turned on for one or more cycles. Every 20-30us, low side FET is turned on briefly to refresh Cboot. Thus the voltage difference between BST and SW can be kept high enough to fully turn on the upper FET.

The output voltage will then be determined by the input voltage minus the voltage drop across the upper N-channel MOSFET and the inductor.

Shutdown Mode

Drive EN to GND to place the WD1601 in shutdown mode. In shutdown mode, the reference, control circuit, main switch, and synchronous switch turn off and the output becomes high impedance. Input current falls to 2μA (Typ.) during shutdown mode.

Over Temperature Protection (OTP)

As soon as the junction temperature (T_J) exceeds 155°C (Typ.), the device goes into thermal shutdown. In this mode, the high-side and low-side MOSFET are turned off.

Application Informations

External component selection for the application circuit depends on the load current requirements. Certain tradeoffs between different performance parameters can also be made.

Output Voltage Setting

The output voltage can be calculated as:

$$V_{OUT} = 0.8 \times \left(1 + \frac{R1}{R2} \right)$$

The external resistive divider is connected to the output. To minimize the current through the feedback divider network, R1 should be larger than 100kΩ. The sum of R1 and R2 should not exceed 1 MΩ, to keep the network robust against noise. An external feed forward capacitor C_{FWD}, is required for optimum load transient response. The value of C_{FWD} should be in the range between 22pF and 33pF.

Route the FB line away from noise sources, such as the inductor or the SW line.

Inductor Selection

The WD1601 high switching frequency allows the use of a physically small inductor. The inductor ripple current is determined by

$$\Delta I_L = \frac{V_{OUT}}{(f)(L)} \left(1 - \frac{V_{OUT}}{V_{IN}} \right)$$

Where ΔI_L is the peak-to-peak inductor ripple current and f is the switching frequency. The inductor peak-to-peak current ripple is typically set to be 40% of the maximum dc load current. Using this guideline and solving for L,

$$L = \frac{V_{OUT}}{f(40\% I_{LOAD(MAX)})} \left(1 - \frac{V_{OUT}}{V_{IN}} \right)$$

It is important to ensure that the inductor is capable of handling the maximum peak inductor current, I_{LPK}, determined by

$$I_{LPK} = I_{LOAD(MAX)} + \frac{\Delta I_L}{2}$$

Inductor Core Selection

Different core materials and shapes will change the size/current and price/current relationship of an inductor. Toroid or shielded pot cores in ferrite or permalloy materials are small and don't radiate much energy, but generally cost more than powdered iron core inductors with similar electrical characteristics. The choice of which style inductor to use often depends more on the price vs. size requirements and any radiated field EMI requirements than on what the WD1601 requires to operate.

Input Capacitor Selection

Capacitor ESR is a major contributor to input ripple in high-frequency DC-DC converters. Ordinary aluminum electrolytic capacitors have high ESR and should be avoided. Low-ESR tantalum or polymer capacitors are better and provide a compact solution for space constrained surface mount designs. Ceramic capacitors have the lowest overall ESR. The input filter capacitor reduces peak currents and noise at the input voltage source. Connect a low ESR bulk capacitor (2.2μF to 10μF) to the input. Select this bulk capacitor to meet the input ripple requirements and voltage rating rather than capacitance value. Use the following equation to calculate the maximum RMS input current:

$$I_{RMS} = \frac{I_{OUT}}{V_{IN}} \sqrt{V_{OUT} \times (V_{IN} - V_{OUT})}$$

Output Capacitor Selection

Ceramic capacitors with low-ESR values have the lowest output voltage ripple and are recommended. At nominal load current, the device operates in PWM mode, and the RMS ripple current is calculated as:

$$I_{RMSOut} = V_{OUT} \times \frac{1 - \frac{V_{OUT}}{V_{IN}}}{L \times f} \times \frac{1}{2 \times \sqrt{3}}$$

At nominal load current, the device operates in PWM mode, and the overall output voltage ripple is the sum of the voltage spike caused by the output capacitor ESR plus the voltage ripple caused by charging and discharging the output capacitor:

$$\Delta V = V_{OUT} \times \frac{1 - \frac{V_{OUT}}{V_{IN}}}{L \times f} \times \left(\frac{1}{8 \times C_{OUT} \times f} + ESR \right)$$

At light load currents, the converter operates in pulse skipping mode, and the output voltage ripple is dependent on the capacitor and inductor values. Larger output capacitor and inductor values minimize the voltage ripple in PSM operation and tighten dc output accuracy in PSM operation.

PC Board Layout Considerations

A good circuit board layout aids in extracting the most performance from the WD1601. Poor circuit layout degrades the output ripple and the electromagnetic interference (EMI) or electromagnetic compatibility (EMC) performance. The evaluation board layout is optimized for the WD1601. Use this layout for best performance. If this layout needs changing, use the following guidelines:

1. Use separate analog and power ground planes. Connect the sensitive analog circuitry (such as voltage divider components) to analog ground; connect the power components (such as input and output bypass capacitors) to power ground. Connect the two ground planes together near the load

to reduce the effects of voltage dropped on circuit board traces. Locate C_{IN} as close to the V_{IN} pin as possible, and use separate input bypass capacitors for the analog.

2. Route the high current path from C_{IN} , through L, to the SW and PGND pins as short as possible.
3. Keep high current traces as short and as wide as possible.
4. Place the feedback resistors as close as possible to the FB pin to prevent noise pickup.
5. Avoid routing high impedance traces, such as FB, near the high current traces and components or near the switch node (SW).
6. If high impedance traces are routed near high current and/or the SW node, place a ground plane shield between the traces.

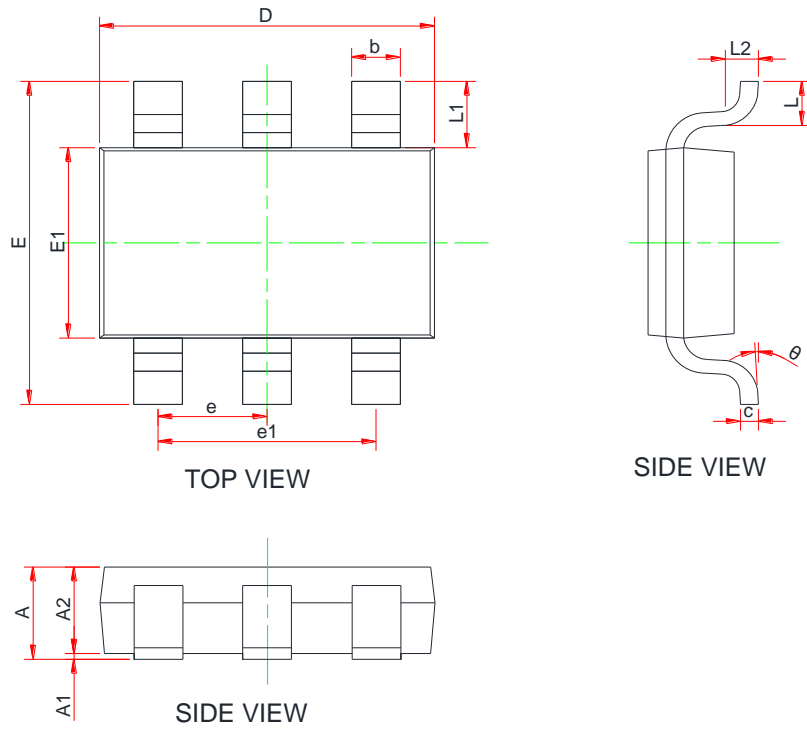
PACKAGE OUTLINE DIMENSIONS
SOT-23-6L

Symbol	Dimensions in Millimeters		
	Min.	Typ.	Max.
A	-	-	1.45
A1	0	-	0.15
A2	0.90	1.10	1.30
b	0.30	0.40	0.50
c	0.10	-	0.21
D	2.72	2.92	3.12
E	2.60	2.80	3.00
E1	1.40	1.60	1.80
e	0.85	0.95	1.05
e1	1.80	1.90	2.00
L	0.30	-	0.60
L1	0.59Ref		
L2	0.25Ref		
θ	0 °	-	8 °

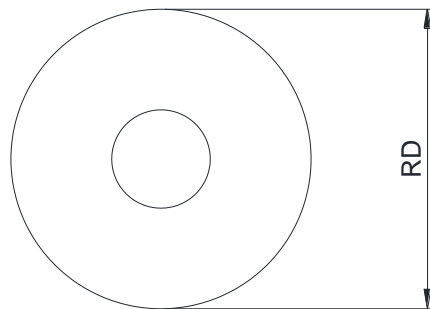
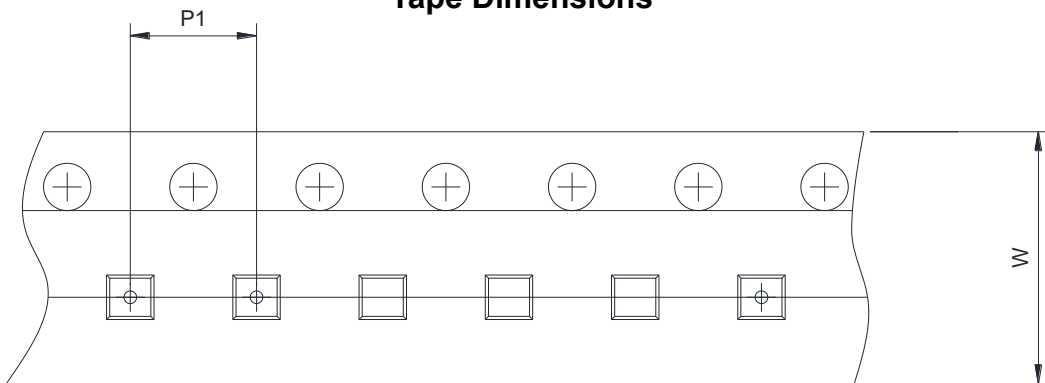
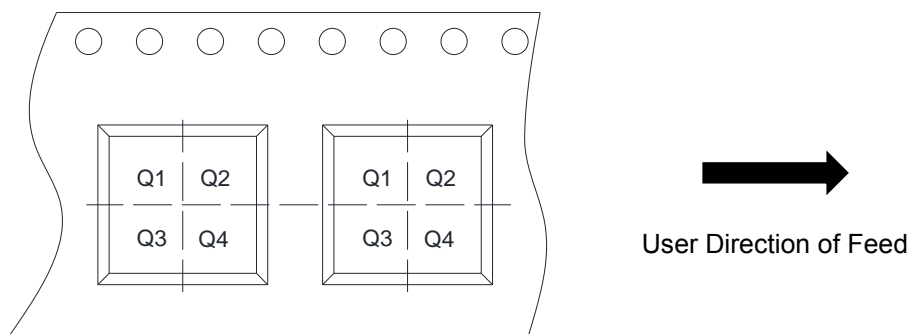
TAPE AND REEL INFORMATION
Reel Dimensions

Tape Dimensions

Quadrant Assignments For PIN1 Orientation In Tape

RD	Reel Dimension	<input checked="" type="checkbox"/> 7inch	<input type="checkbox"/> 13inch
W	Overall width of the carrier tape	<input checked="" type="checkbox"/> 8mm	<input type="checkbox"/> 12mm <input type="checkbox"/> 16mm
P1	Pitch between successive cavity centers	<input type="checkbox"/> 2mm	<input checked="" type="checkbox"/> 4mm <input type="checkbox"/> 8mm
Pin1	Pin1 Quadrant	<input type="checkbox"/> Q1	<input type="checkbox"/> Q2 <input checked="" type="checkbox"/> Q3 <input type="checkbox"/> Q4