

APPROVAL SPECIFICATIONS

Title. HDMI USB CONNECTOR

Product Model. HDMI -201

Customer's Part NO.

Customer's Model:

Customer's Approval Requested.

Please return this copy as a certification of your approval.

Checked by: _____ Date: _____

Approved by: _____ Date: _____

APPROVE	REVIEW	POLT
王凯	林永坚	陈旺

XUNPU ELECTRONICS CO.,LTD

CUSTOMER	CUSTOMER'S P/N	GYE'S P/N	PRODUCT	REVISION
		HDMI-201	HDMI USB CONNECTOR	

产品符合ROHS

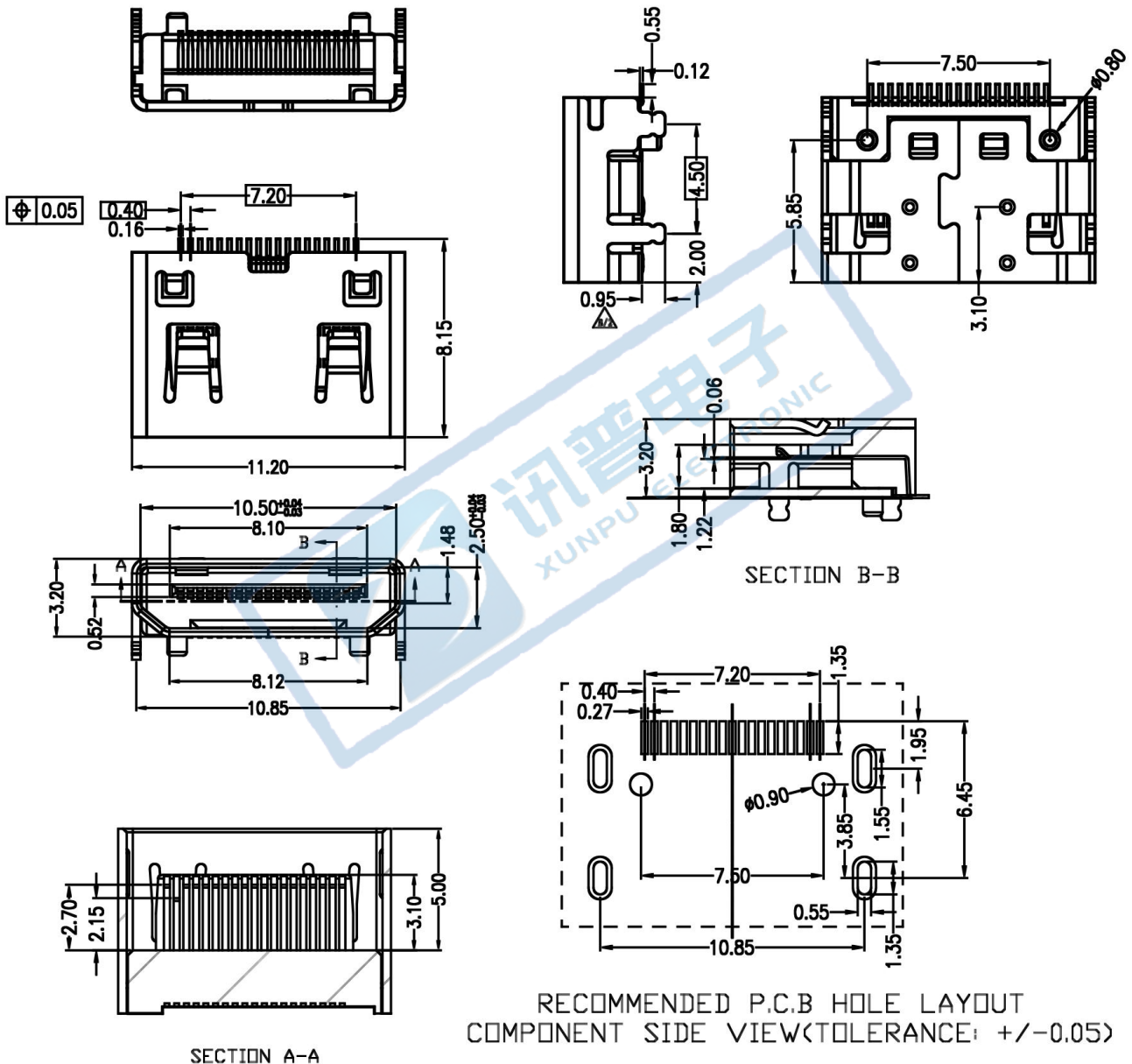

RECOMMENDED P.C.B HOLE LAYOUT COMPONENT SIDE VIEW(TOLERANCE: +/-0.05)

General tolerance: $\pm 0.2\text{mm}$

APPROVE BY	王凯 10.05.09	CHECKED BY	李永坚 10.05.09	PRPARE BY	陈旺 10.05.09
------------	-------------	------------	--------------	-----------	-------------

東莞市訊普電子科技有限公司

HDMI系列產品SPEC

TEST ITEM		REQUIREMENT	
1	Examination of Product	Meets requirements of product drawing. No physical damage.	Visual inspection.
2	Operating Temperature	-55°C ~ +85°C	
3	Storage Temperature	-20°C ~ +85°C	
ELECTRICAL REQUIREMENT			
4	Rating Voltage	40VAC max	on any signal pin with respect to the shield
5	Rating Current	0.5A Min type A/B/C/E; 0.3A Min type D	55°C ,maximum ambient 85°C ,maximum temperature change (ANSI/EIA 364-70,TP-70)
6	Contact Resistance	[30] m Ohm Max(Initial) [50] m Ohm Max(Final)	Subject mated contacts assembled in housing to 20mV Max open circuit at 150mA Max. EIA-364-23.
7	Dielectric withstanding Voltage	No breakdown	[500]VAC(Type A/B/C/E) [150]VAC(Type D) for 1minute Test between adjacent circuits of unmated connector. EIA-364-20C
8	Insulation Resistance	[100] M Ohm Min.(unmated) [10] M Ohm Min.(mated)	Impressed voltage 500 VDC(unmated) 150VDC(mated). Test between adjacent circuits of unmated connector. EIA-364-21C.
9	Temperature Rising	30°C Max. Under loaded rating current	Contact series-wired, apply test current of loaded rating current to the circuit, and measure the temperature rising by probing on soldered areas of contacts, after the temperature becomes stabilized deduct ambient temperature from the measured value.
Mechanical Requirement			
10	Connector Mating Force	44.1N Max	Operation Speed : [25] mm/min. Measure the force required to mate connector. EIA-364-13
11	Connector Unmating Force	9.8N-39.2N type A 7N-25N type C 5N-25N type D 3N-25N after 5000cycles	Operation Speed : [25] mm/min. Measure the force required to unmate connector. EIA-364-13
12	Durability	30m ohms Max change from initial per contact pair	Automatic cycling to 10000 cycles(type A) 5000cycles(type C and D) Rate:100±50 cycles per hour. EIA-364-09C
13	Vibration	No discontinuity at 1 μ s or longer(each contact) when continuity is tested per ANSI/EIA-364-46	ANSI/EIA-364-28,Condition III,Method 5A,15 minute/axis
14	Mechanical Shock	No discontinuity at 1 μ s or longer(each contact) when continuity is tested per ANSI/EIA-364-46	ANSI/EIA-364-27 Condition A(specified pulse)
15	Solder ability	At least 95% of the immersed area shall be covered with new solder	1)Temperature of fused solder: 245±5°C. 2)Dipping time:5+0.5s EIA 364-52
Environmental Requirements			

東莞市訊普電子科技有限公司

HDMI系列產品SPEC

TEST ITEM		REQUIREMENT	
16	Resistance to Solder Heat	Forming resin shall not be distorted, and terminations shall not be separated.	1) Depth of dipping termination: the distance between the mounting surface and solder surface shall be 1 mm to 2mm. 2)Temperature:245±5°C. 3) Dipping time: 10±1s Socket EIA 364-56
17	Thermal Shock	No physical damage to the samples and LLCR-50 mΩ max per contact	Mated connectors exposed to 10 cycles between - 55°C to 85°C, 30 minutes duration at both temperature extremes EIA 364-32
18	Steady State Humidity	No physical damage to the samples and can pass the Dielectric Withstanding Voltage & Insulation Resistance	Expose mated connectors to a temperature of 40 ±2°C with relative humidity of 90-95% for 168 hours Min(seven complete cycles). Remove surface moisture and air dry for 24 hours. prior to measurement. EIA 364-31
19	Temperature Life (Heat Aging)	30m ohms Max change from initial per contact pair All sample to be mated	ANSI/EIA-364-17 Condition 4 105°C for 250 hours,Method A,mated
20	Salt Spray	Visual Inspection-No physical damageLLCR-50 mΩ max per contact	Mated connector expose to 5% salt concentration for 12 hours at temperature 35+2 °C .After the test specimens shall be washed with running water and dried naturally EIA 364-26

Product Qualification and Requalification test

Test or Examination	Test Group									
	A	B	C	D	E	F	G	H	I	J
	Test Sequence (a)									
Examination of Product	1, 7	1, 9	1, 6	1, 5	1, 5	1, 5	1, 5	1, 3	1, 3	1, 3
Contact Resistance		2, 8	2, 5	2, 4	2, 4	2, 4	2, 4			
Dielectric withstanding	3, 6									
Insulation Resistance	2, 5									
Temperature Rising								2		
Mating Force		3, 7								
Unmating Force		4, 6								
Durability		5								
Vibration			3							
Mechanical Shock			4							
Solderability										2
Resistance to Soldering									2	
Thermal Shock				3						
Humidity Temperature	4				3					
Temperature Life						3				
Salt Spray							3			

備注

無客戶指定增加測試項目外，依照此標準進行產品可靠性評估。

審核：皮洪斌

制定：何星