

HG9910 UNIVERSAL HIGH BRIGHTNESS LED DRIVER

FEATURES

- >90% Efficiency
- 8V to 450V input range
- Constant-current LED driver
- Applications from a few mA to more than 1A output
- LED string from one to hundreds of diodes
- PWM Low-Frequency Dimming via Enable pin

Applications

- DC/DC or AC/DC LED Driver applications
- RGB Backlighting LED Driver
- Back Lighting of Flat Panel Displays
- General purpose constant current source
- Signage and Decorative LED Lighting
- Automotive

Description

The HG9910 is a PWM high-efficiency LED driver control IC. It allows efficient operation of High Brightness (HB) LEDs from voltage sources ranging from 8VDC up to 450VDC. The HG9910 controls an external MOSFET at fixed switching frequency up to 300kHz. The frequency can be programmed using a single resistor. The LED string is driven at constant current rather than constant voltage, thus providing constant light output and enhanced reliability. The output current can be programmed between a few milliamps and up to more than 1.0A.

HG9910 uses a rugged high voltage junction isolated process that can withstand an input voltage surge of up to 450V. Output current to an LED string can be programmed to any value between zero and its maximum value by applying an external control voltage at the linear dimming control input of the HG9910. The HG9910 provides a low-frequency PWM dimming input that can accept an external control signal with a duty ratio of 0-100% and a frequency of up to a few kilohertz.

Functional Block Diagram

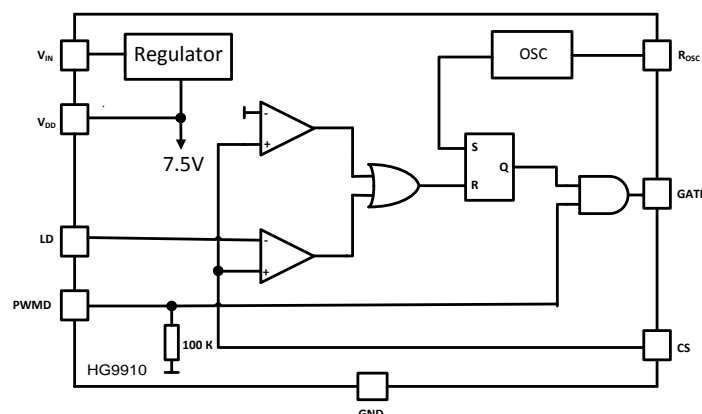

Package Types

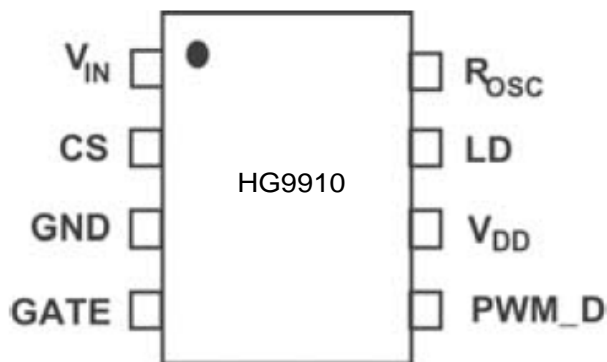

8-Pin DIP/SOIC

Table 1: Pin Description

Pin #	Name	Description
1	VIN	Input voltage 8V to 450V DC
2	CS	Senses LED string current
3	GND	Device ground
4	GATE	Drives the gate of the external MOSFET
5	PWMD	Low Frequency PWM Dimming pin, also Enable input. Internal 100kΩ pull-down to GND
6	VDD	Internally regulated supply voltage. 7.5V nominal. Can supply up to 1mA for external circuitry. A sufficient storage capacitor is used to provide storage when the rectified AC input is near the zero crossings.
7	LD	Linear Dimming by changing the current limit threshold at current sense comparator
8	Rosc	Oscillator control. A resistor connected between this pin and ground sets the PWM frequency.

1.0 Electrical Characteristics

Absolute Maximum Ratings

Parameter	Rating	Unit
VIN to GND	-0.5 to +470	V
CS	-0.3V to +15.8	V
LD, PWMD to GND	-0.3V to +15.1	V
GATE to GND	-0.3V to +15.8	V
VDD MAX	13.5	V
ESD Capability, all pads except Pad 1 (VIN) and Pad 7,8 (VDD)	2.0	kV
Maximum Voltage on Pad 1 (VIN) and Pad 7,8 (VDD)	470	V
Operating Temperature Range	-40 to +85	°C
Junction Temperature	+125	°C
Storage Temperature Range	-65 to +150	°C
Power Dissipation @+25 °C for DIP-8	900	mW
Power Dissipation @+25 °C for SO-8	630	mW

Note: Stresses above those listed under "Absolute Maximum Ratings" may cause permanent damage to the device. This is a stress rating only and functional operation of the device at those or any other conditions, above those indicated in the operational listings of this specification, is not implied. Exposure to maximum rating conditions for extended periods may affect device reliability.

Electrical Characteristics¹

Symbol	Description	Min	Typ	Max	Unit	Conditions
V _{INDC}	Input DC supply voltage range	8.0		450	V	DC input voltage
I _{INsd}	Shut-Down mode supply current		0.5	1	mA	Pin PWM_D to GND, VIN= 8V
V _{DD}	Internally regulated voltage	7.0	7.5	8.0	V	VIN = 8-450V, IDD(ext)=0, pin Gate open
V _{DDmax}	Maximal pin VDD voltage			13.5	V	When an external voltage applied to pin VDD
I _{DD(ext)}	VDD current available for external circuitry ¹			1.0	mA	VIN = 8-100V
UVLO	VDD undervoltage lockout threshold	6.45	6.7	6.95	V	VIN rising
ΔUVLO	VDD undervoltage lockout hysteresis		500		mV	VIN falling
V _{EN(lo)}	Pin PWMD input low voltage			1.0	V	VIN = 8-450V
V _{EN(hi)}	Pin PWM_D input high voltage	2.4			V	VIN = 8-450V
R _{EN}	Pin PWM_D pull-down resistance	50	100	150	κOhm	VEN = 5V
V _{CS(hi)}	Current sense pull-in threshold voltage	225	250	275	mV	@TA = -40°C ÷ +85°C
V _{GATE(hi)}	GATE high output voltage	V _{DD} -0.3		V _{DD}	V	I _{OUT} = 10 mA
V _{GATE(lo)}	GATE low output voltage	0		0.3	V	I _{OUT} = -10 mA
f _{OSC}	Oscillator frequency	20 80	25 100	30 120	κHz κHZ	Rosc = 1.00 MOhm Rosc = 226 κOhm
D _{MAXhf}	Maximum Oscillator PWM Duty Cycle			100	%	F _{PWMhf} = 25kHz, at GATE, CS to GND
V _{LD}	Linear Dimming pin voltage range	0		250	mV	@TA = <85°C, Vin = 12 V
T _{BLANK}	Current sense blanking interval	150	215	280	ns	V _{CS} = 0.55V _{LD} , V _{LD} = V _{DD}
t _{DELAY}	Delay from CS trip to GATE lo			300	ns	Vin = 12 V, V _{LD} = 0.15, V _{CS} = от 0 до 0.22V после T _{BLANK}
t _{RISE}	GATE output rise time ²		30	50	ns	C _{GATE} = 500 pF
t _{FALL}	GATE output fall time ²		30	50	ns	C _{GATE} = 500 pF

1. Also limited by package power dissipation limit, whichever is lower

Important statement:

Huaguan Semiconductor Co,Ltd. reserves the right to change the products and services provided without notice. Customers should obtain the latest relevant information before ordering, and verify the timeliness and accuracy of this information.

Customers are responsible for complying with safety standards and taking safety measures when using our products for system design and machine manufacturing to avoid potential risks that may result in personal injury or property damage.

Our products are not licensed for applications in life support, military, aerospace, etc., so we do not bear the consequences of the application of these products in these fields.

Our documentation is only permitted to be copied without any tampering with the content, so we do not accept any responsibility or liability for the altered documents.