



# MIANYANGGAOXINDISTRICTJING WEIDASCIENCE & TECHNOLOGYCO.,LTD

## 10/100/1000Base SMD Transformer module

Page:1/6

- IEEE 802.3ab/ANSI X3.263 compliant performance
- Designed for IP phone or switch applications
- Compact footprint
- Some models offer AutoMDIX cap
- Operating temperature range :-0°C to +70°C.
- Storage temperature range: -0°C to +85°C.

### Electrical Specifications @ 25°C

Part Number	Turns Ratio (±5%)		OCL(uH Min) @100KHz/0.1V with 8.0mA DC	Insertion Loss (dB Max)	HI-POT (Vrms)
	TX	RX		1-100MHz	
SG48001 G	1CT:1CT	1CT:1CT	350	-1.0	1500
SG48001A G	1CT:1CT	1CT:1CT	350	-1.0	1500
SG48001AT G	1CT:1CT	1CT:1CT	350	-1.0	1500
SG48002 G	1CT:1CT	1CT:1CT	350	-1.0	1500
SG48003 G	1CT:1CT	1CT:1CT	350	-1.0	1500
SG48004 G	1CT:1CT	1CT:1CT	350	-1.2	1500
SG48004T G	1CT:1CT	1CT:1CT	350	-1.2	1500
SG48005 G	1CT:1CT	1CT:1CT	350	-1.0	1500
SG48006 G	1CT:1CT	1CT:1CT	350	-1.0	1500
SG48007 G	1CT:1CT	1CT:1CT	350	-1.4	1500
SG48008 G	1CT:1CT	1CT:1CT	350	-1.0	1500
SG48009 G	1CT:1CT	1CT:1CT	350	-1.2	1500
SG48010 G	1CT:1CT	1CT:1CT	350	-1.0	1500

Continue

Part Number	Return Loss (dB Min)					Cross Talk (dB Min)			DCMR (dB Min)		
	1-30MHz	40MHz	50MHz	60-80MHz	100MHz	30MHz	60MHz	100MHz	30MHz	60MHz	100MHz
SG48001 G	-16	-14.4	-13.1	-12	-10	-43	-37	-33	-40	-35	-30
SG48001A G	-18	-14.4	-13.1	-12	-10	-43	-37	-33	-40	-35	-30
SG48001AT G	-18	-14.4	-13.1	-12	-10	-43	-37	-33	-40	-35	-30
SG48002 G	-16	-14.4	-13.1	-12	-10	-43	-37	-33	-40	-35	-30
SG48003 G	-18	-14.4	-13.1	-12	-10	-43	-37	-33	-40	-35	-30
SG48004 G	-16	-14	-13	-12	-10	-43	-37	-33	-43	-37	-33
SG48004T G	-16	-14	-13	-12	-10	-43	-37	-33	-43	-37	-33
SG48005 G	-18	-	-	-12	-10	-43	-37	-33	-40	-35	-30
SG48006 G	-18	-14.4	-13.1	-12	-10	-43	-37	-33	-40	-35	-30
SG48007 G	-16	-14.4	-13.1	-12	-10	-43	-37	-33	-40	-35	-30
SG48008 G	-18	-14.4	-13.1	-12	-10	-43	-37	-33	-40	-35	-30

:



# MIANYANGGAOXINDISTRICTJING WEIDASCIENCE & TECHNOLOGYCO.,LTD

## 10/100/1000Base SMD Transformer module

SG48009 G	-16	-14	-13	-12	-10	-43	-37	-33	-43	-37	-33
SG48010 G	-18	-14.4	-13.1	-12	-10	-43	-37	-33	-40	-35	-30

**Mechanicals:**

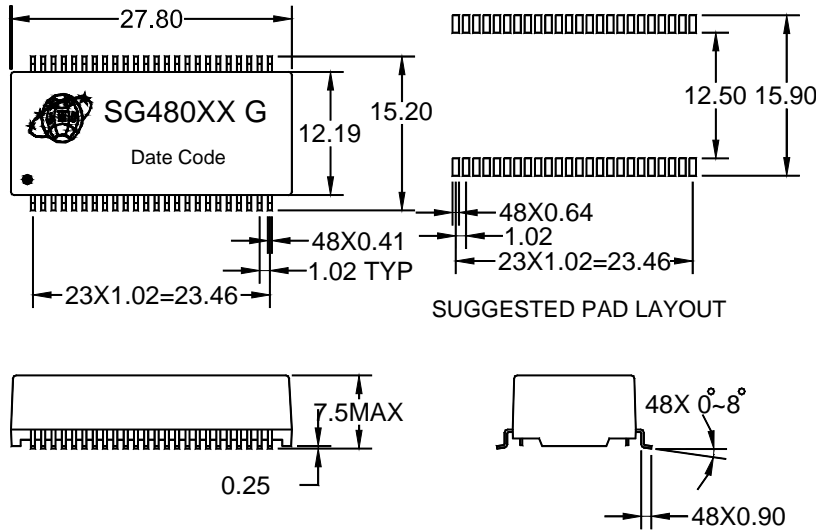

Unless otherwise specified , all tolerance are  $xx.xx \pm 0.25$   $0.xx \pm 0.05$

**SCHEMATICS:**

SG48001 G

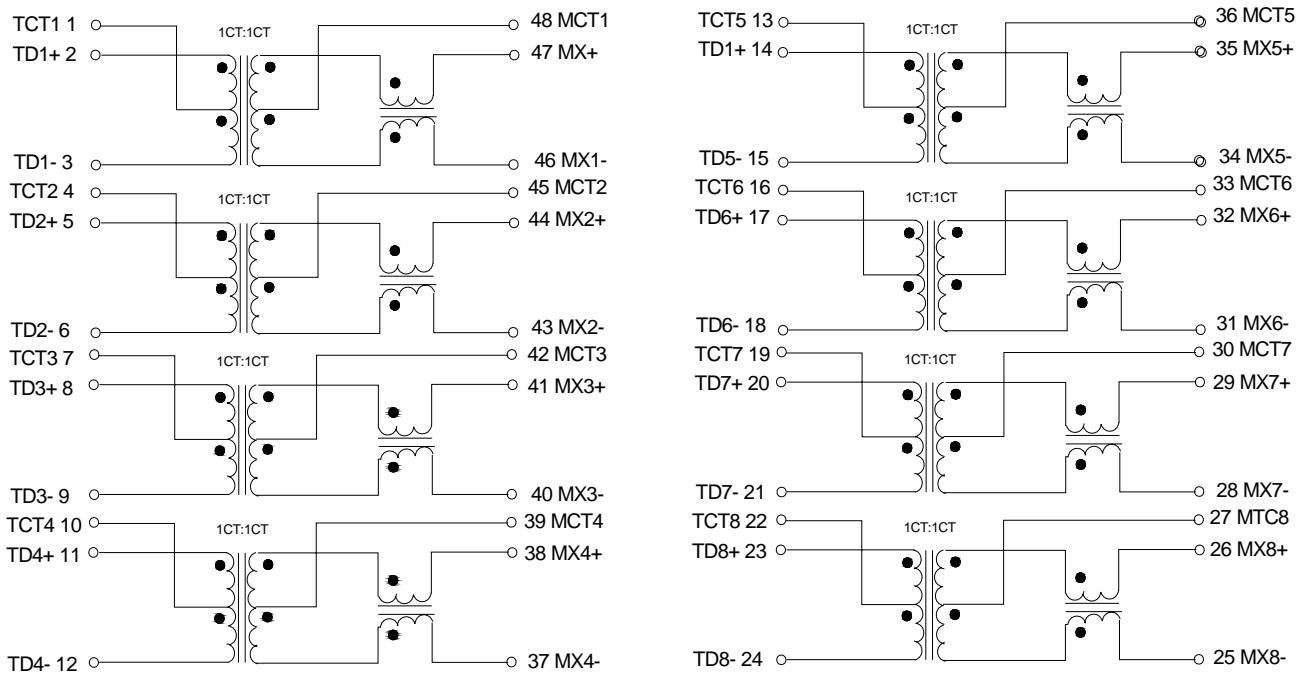



## 10/100/1000Base SMD Transformer module

### SG48001A G/SG48001AT G

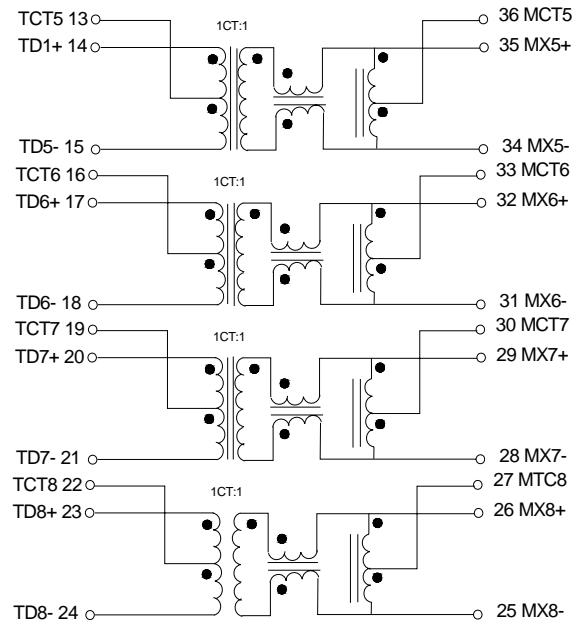
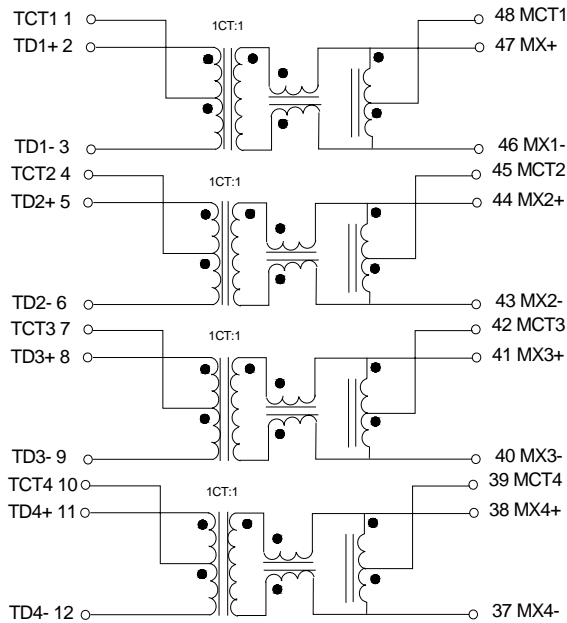

### SG48002 G

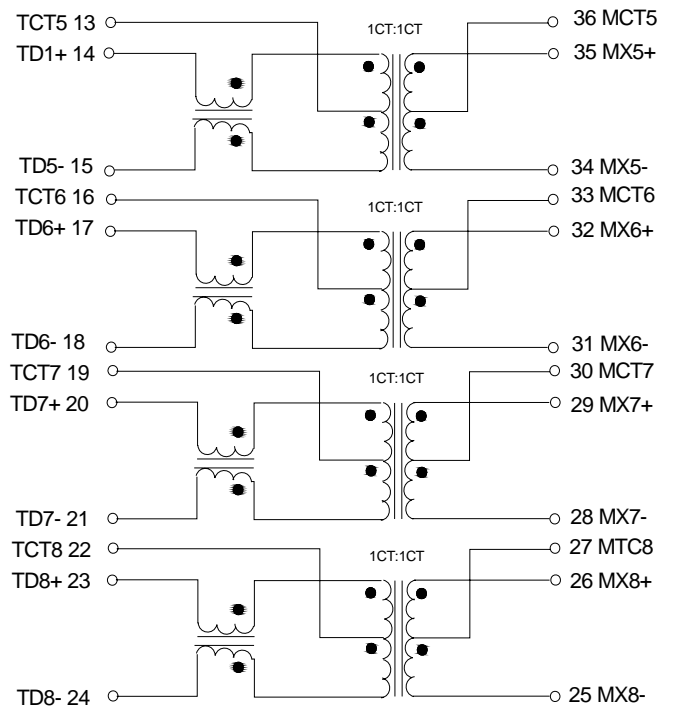
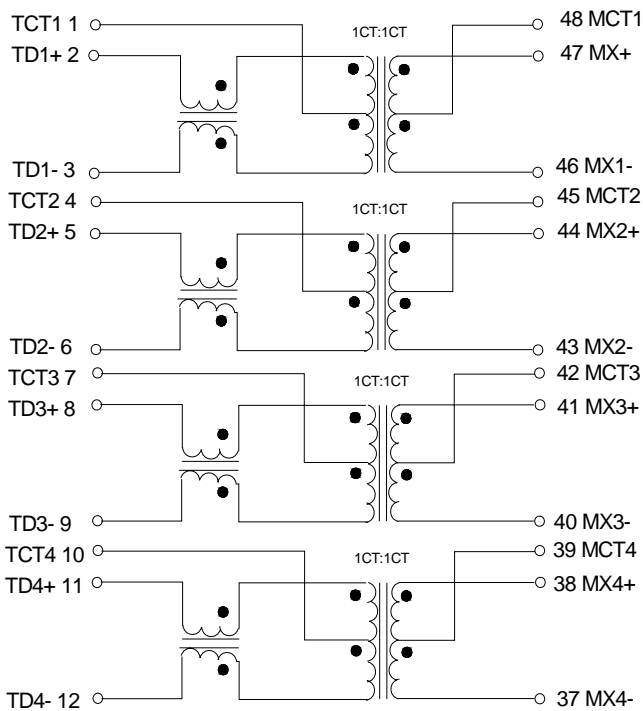



## 10/100/1000Base SMD Transformer module

### SG48003G

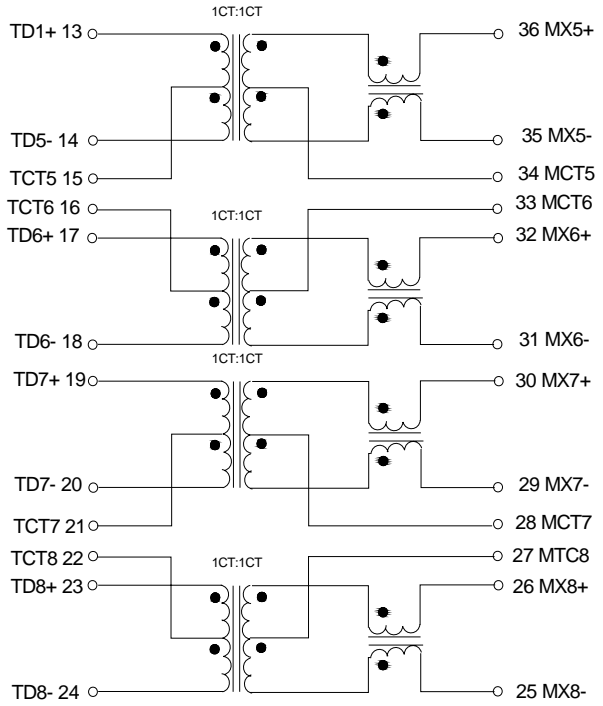
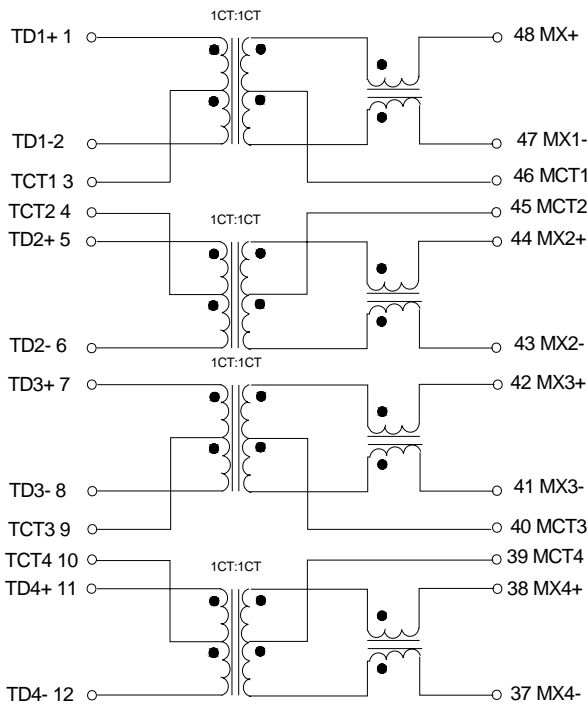

### SG48004 G/SG48004T G

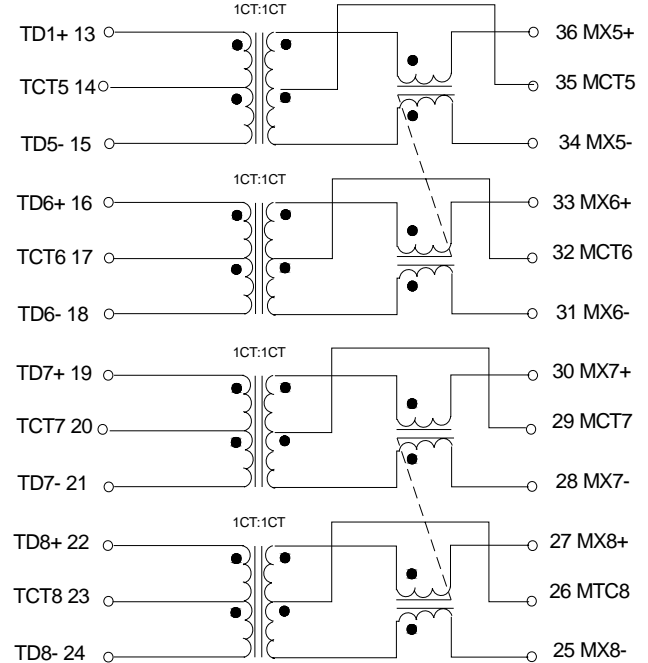
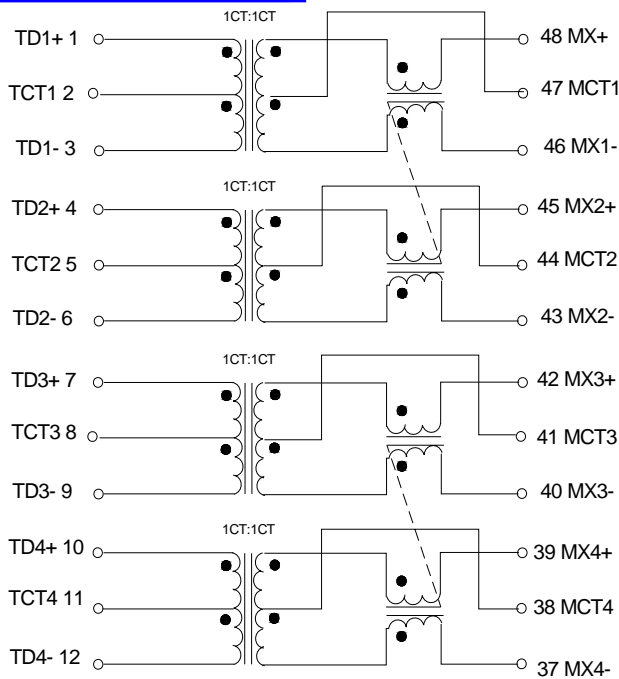



## 10/100/1000Base SMD Transformer module

### SG48005 G

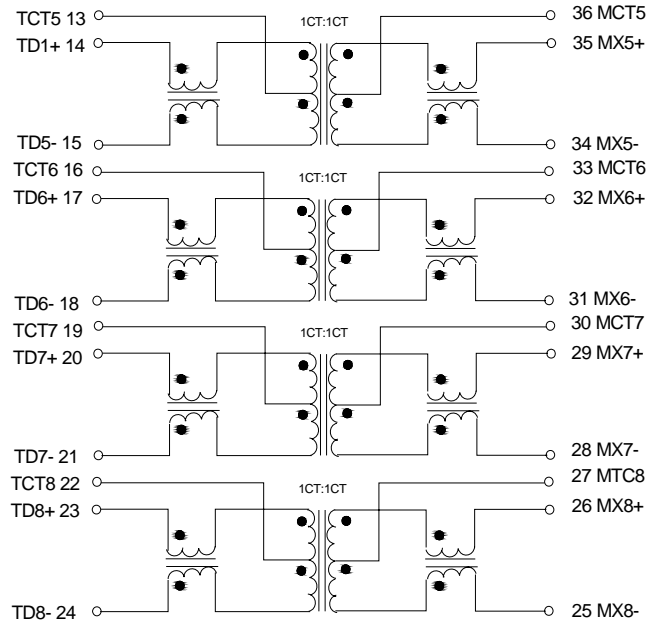
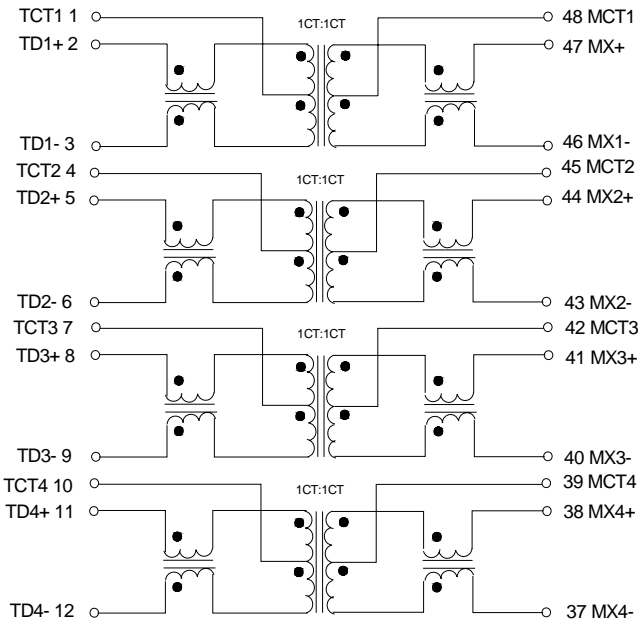

### SG48006 G

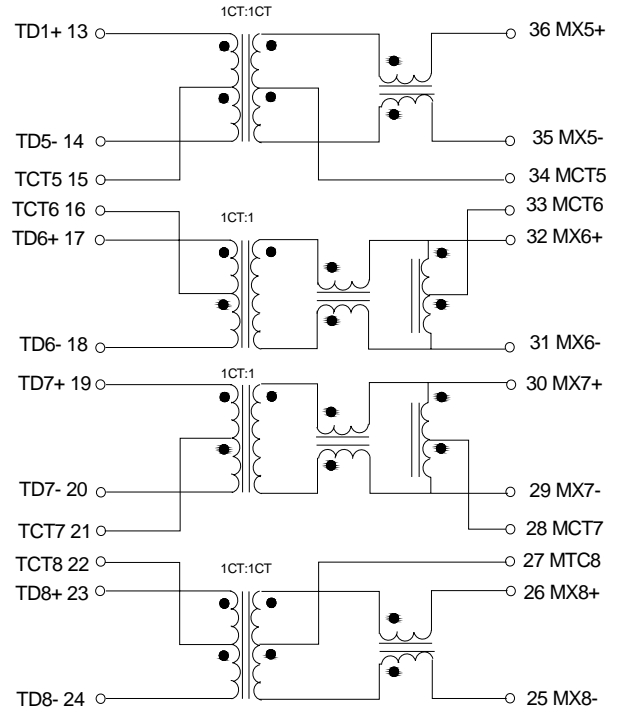
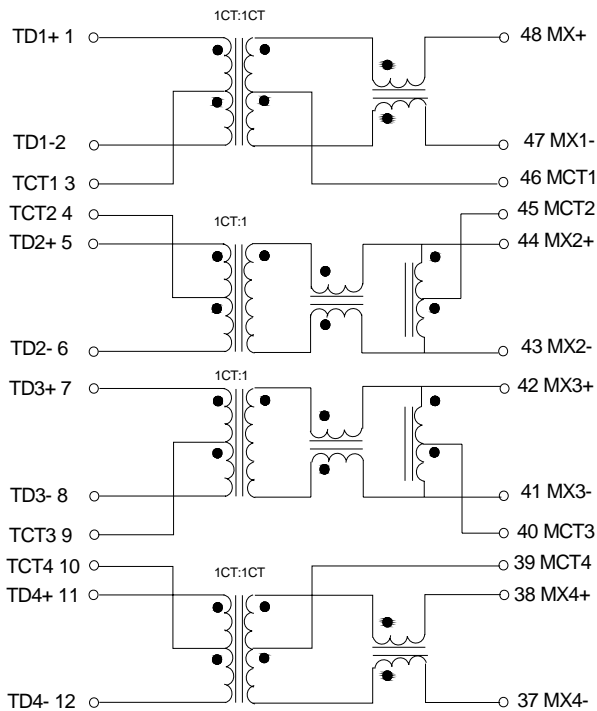



## 10/100/1000Base SMD Transformer module

### SG48007 G

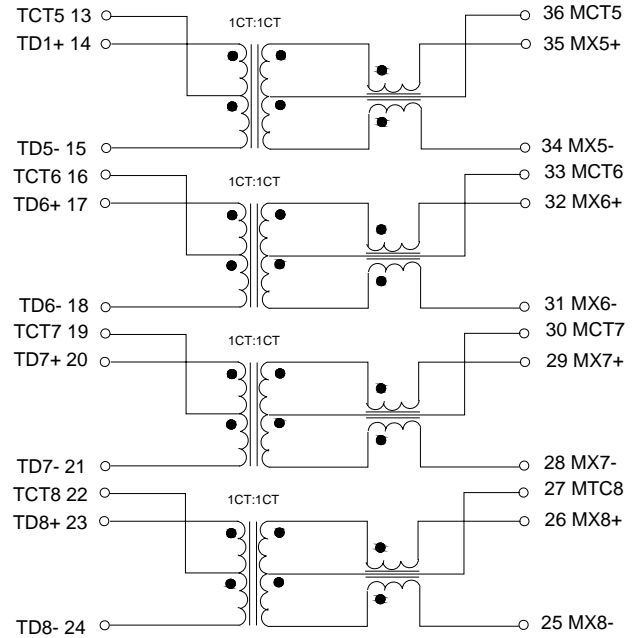
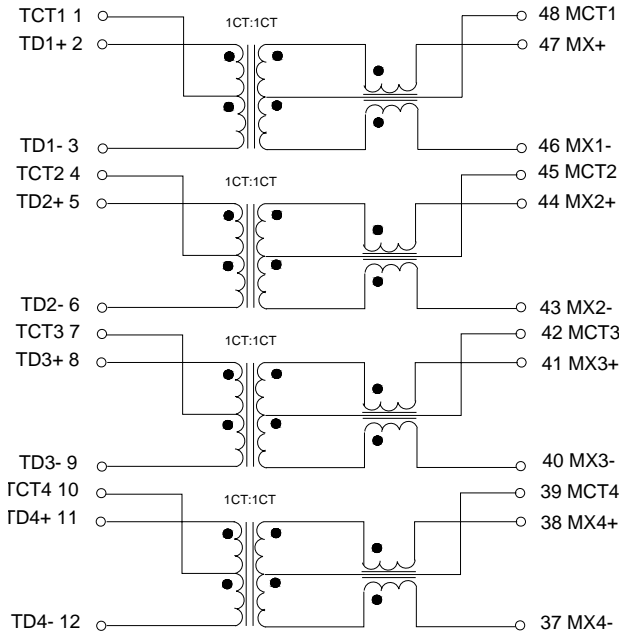

### SG48008 G

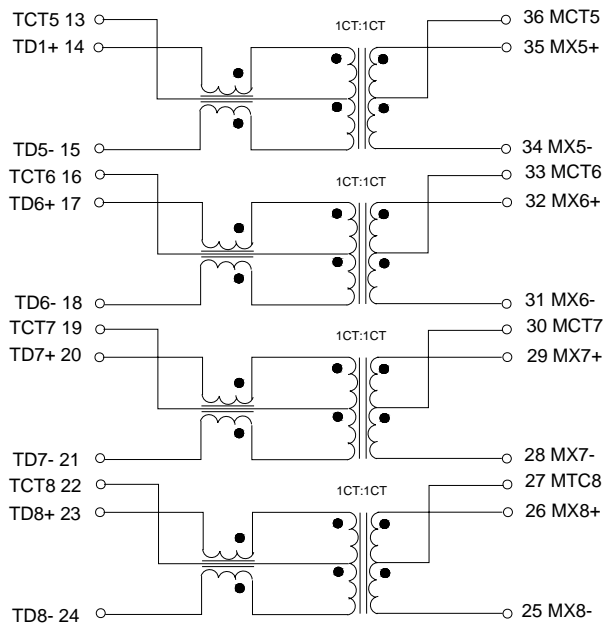
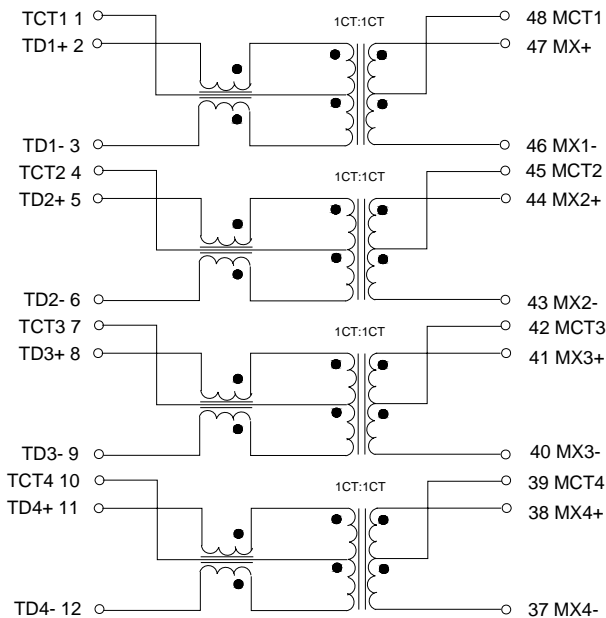



## 10/100/1000Base SMD Transformer module

### SG48009 G

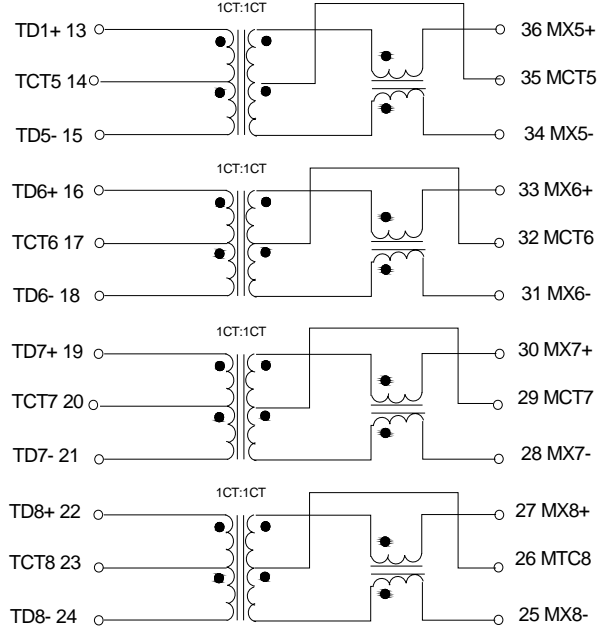
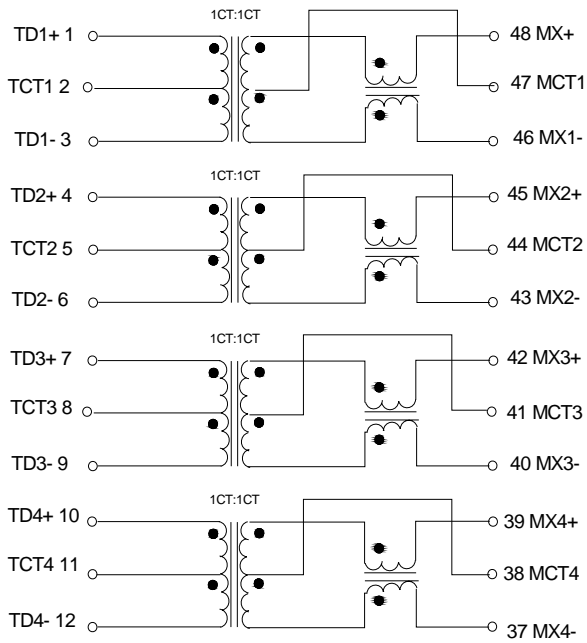

### SG48010 G

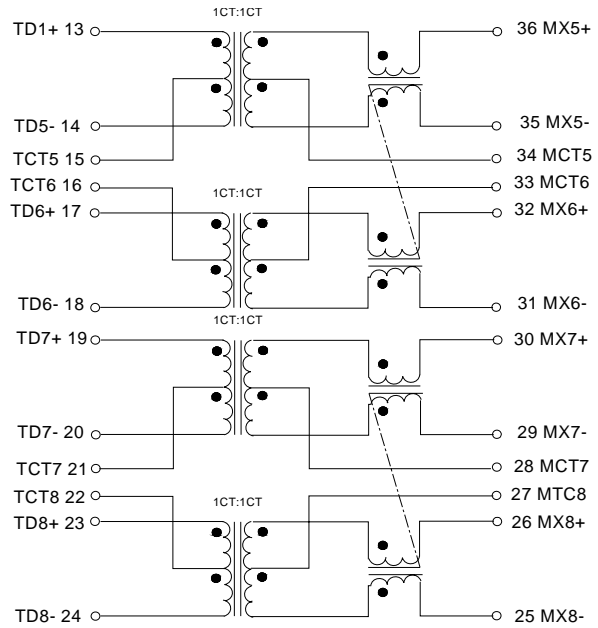
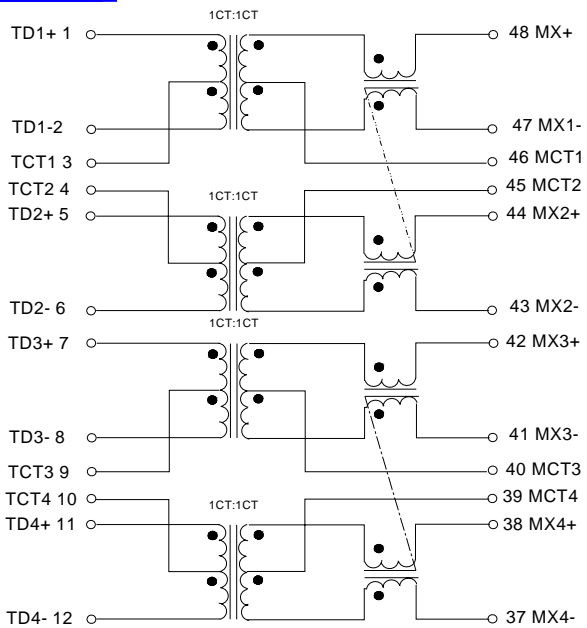

Specification	Packing Manner	Q'ty per Tube/Reel	Q'ty/lnner box	Q'ty/Carton
SG480XX G	TUBE	18	720	2880
	REEL	350	700	1400