



SPECIFICATION FOR APPROVAL

CUSTOMER : _____

PRODUCT TYPE : SMD TCXO 2.5 * 2.0

NOMINAL FREQ. : 32 MHz

TXC P/N : 7L32003004

REVISION : S1

CUSTOMER P/N : _____

PM / SALES : _____

DATE : _____

CUSTOMER CONFIRMATION : (Singnature) _____
(Date) _____

- (1) TXC requires one copy returned with signature and title of authorized individual that signifies acceptance of the attached specifications.
- (2) Orders received and accepted by TXC after return of signed copy of specification will be produced per these specifications.
- (3) Any changes to these specifications must be agreed upon by both parties and new revision of the Product Specification Sheet will be issued.
- (4) Any issuance of purchase order prior to consigning back the Approval page of "Specification Sheets" from customers will be regarded as the agreement on the contents of these specifications.

Attachment(s):

- 1. Product Specification Sheet
- 2. Testing Report(Electrical & Temperature)
- 3. Reliability Report

MSL:Level 1
RoHS Compliant

(for glass crystal only : Pb used in sealing glass material is exempt from EU directive)



SPECIFICATION FOR APPROVAL

CUSTOMER : _____

PRODUCT TYPE : SMD TCXO 2.5 * 2.0

NOMINAL FREQ. : 32 MHz

TXC P/N : 7L32003004

REVISION : S1

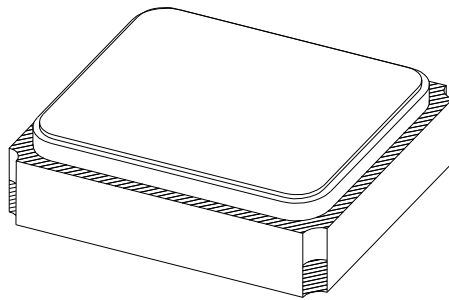

PE/RD	QA	MFG
<i>Eric Tsao</i>		
2016/5/18		

NOTE:

- (1) The green product standard set by TXC is based upon the international standards. Related information is publicly described on the TXC's Website, and updated regularly. The document is compliant with the latest green product quality system directives at the time.
- (2) Revision "Sx" is for engineering samples only. PE/RD's approval required.
- (3) Revision "Ax" is production ready. PE, QA and MFG's approval required.

MSL:Level 1
RoHS Compliant

(for glass crystal only : Pb used in sealing glass material is exempt from EU directive)

■ ELECTRICAL SPECIFICATIONS

Item	Parameters		Condition	Electrical Specifications				Note
				MIN	TYP	MAX	UNITS	
1	Nominal Frequency			32.000000			MHz	
2	Operating Temperature Range			-40		+85	°C	
3	Supply Voltage			3.14	3.30	3.46	V	
4	Current Drain					2.0	mA	
5	Output Level			0.8			V	1
6	Output Type			Clipped Sinewave				
7	Output Load		Resistance	9	10	11	kΩ	
8			Capacitance	9	10	11	pF	
9	Initial Frequency Tolerance		After 2 times reflow			±2.0	ppm	2
10	Frequency Stability	vs. Temperature	Temp: -30 ~ +85°C			±0.5	ppm	3
11			Temp: -40 ~ -30°C			±1.0	ppm	
12		vs. Load	Load: 10 kΩ // 10 pF ±10%			±0.2	ppm	
13		vs. Supply Voltage	Vcc: 3.3 V ±5%			±0.1	ppm	
14	Slope of Frequency Drift over Temperature		Temp: -40 ~ +85°C			±0.3	ppm/°C	4
15	Static Temperature Hysteresis					±0.6	ppm	5
16	Storage Temperature			-40		+85	°C	
17	Duty Cycle			40	50	60	%	
18	Aging		1 year			±1.0	ppm	
19	Phase Noise	@ 1 Hz offset			-60		dBc/Hz	
20		@ 10 Hz offset			-88		dBc/Hz	
21		@ 100 Hz offset			-118		dBc/Hz	
22		@ 1 kHz offset			-132		dBc/Hz	
23		@ 10 kHz offset			-145		dBc/Hz	

Note 1 Decoupling capacitor (1000 pF) is required in external circuit

Note 2 Refer to nominal frequency

Note 3 Refer to frequency at 25±2°C

Note 4 Minimum of 1 frequency reading every 2°C over temperature, based on temperature varied at maximum of 2°C per minute.

Note 5 Frequency change after reciprocal temperature ramped over the operating range. frequency measured before and after at 25degC

TESTING CIRCUIT

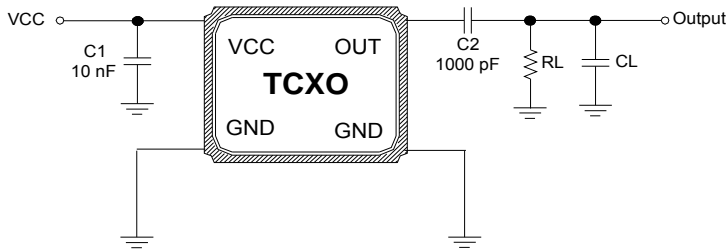

External Components

Name	Function
C1	AC Noise Bypass for VCC
C2	DC Block for Output
RL	Load Resistance
CL	Load Capacitance

Note: Bypass capacitor (C1) and DC blocking capacitor (C2) should be placed.

DIMENSIONS

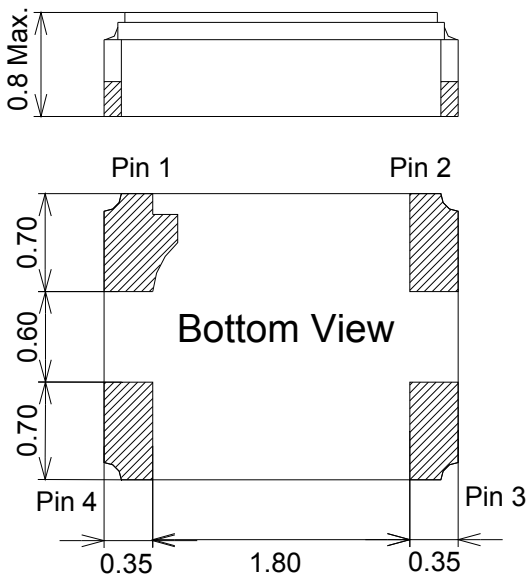
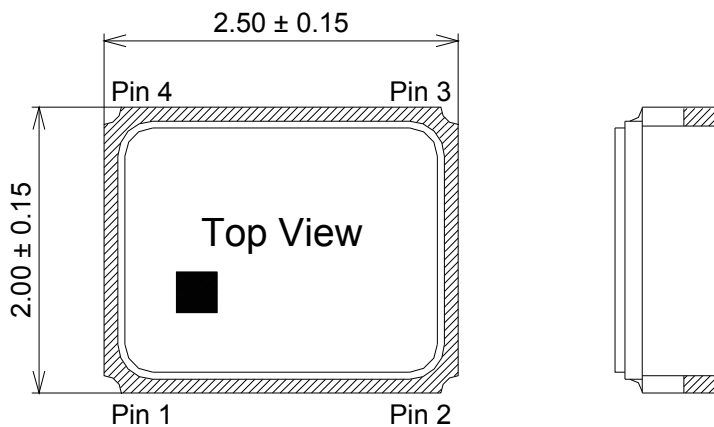

Unit: mm

Pin Connection

Name	Function
Pin 1	GND or NC
Pin 2	GND
Pin 3	OUTPUT
Pin 4	VCC

Recommended Land Pattern

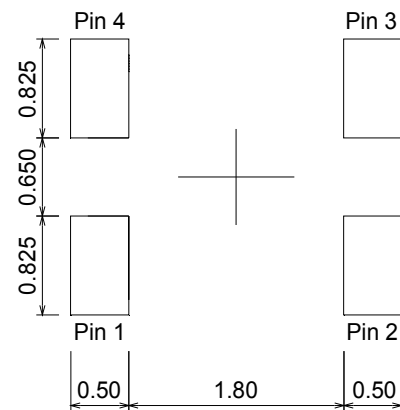

■ SUGGESTED REFLOW PROFILE

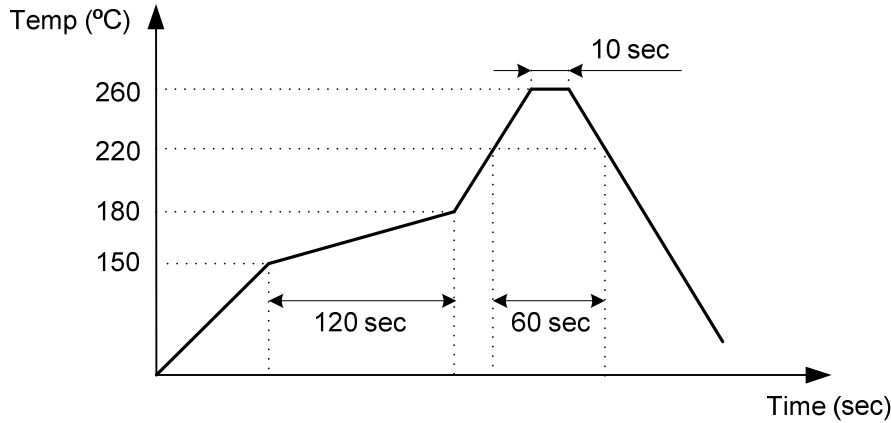

Note 1: Period while temperature exceeds the solder melting point : 220°C should be less than 200 sec.

Note 2: Period while temperature stays at the top melting point : 260°C should be less than 30 sec.

■ MARKING

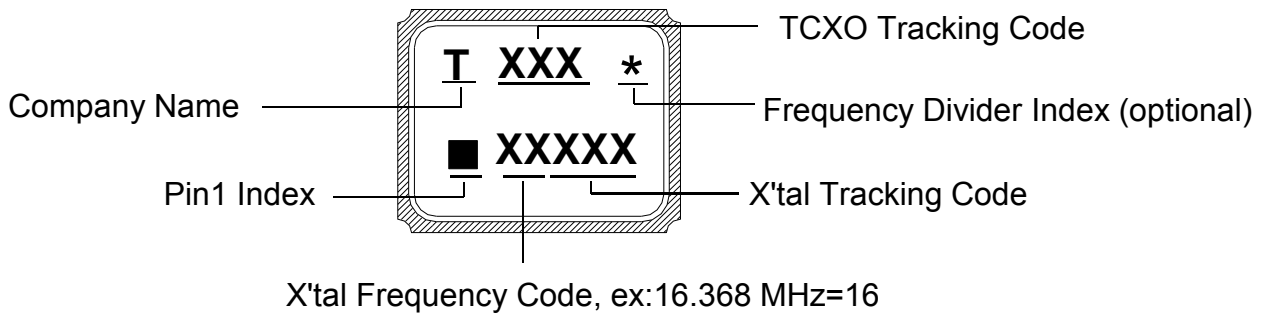

PACKING : (EIA-481-2)

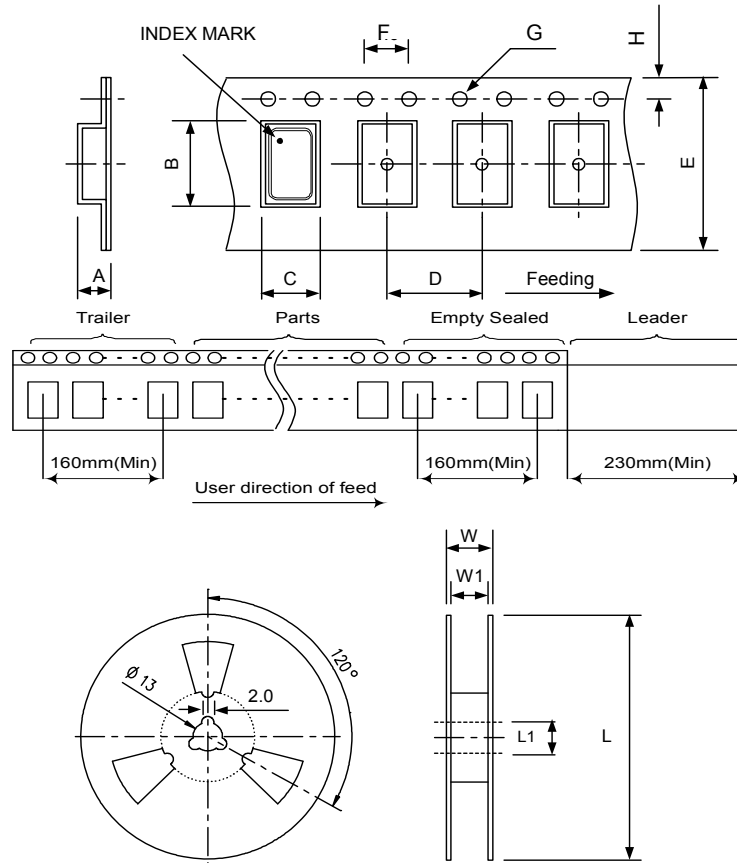

Unit: mm

DIMENSIONS (mm)	A	B	C	D	E	F	G	H	L	L1	W	W1	Standard Reel Quantity is 3,000 pcs per reel
	1.15	2.70	2.25	4.00	8.00	4.00	1.55	1.75	178	13.0	11.6	8.4	

WEIGHT

0.0135 g / piece(TYP), 40 ± 2 g / 3 kpcs(regardless of tape weight)

■ STRUCTURE ILLUSTRATION

Crystal Enclosure Seal: Seam Welding

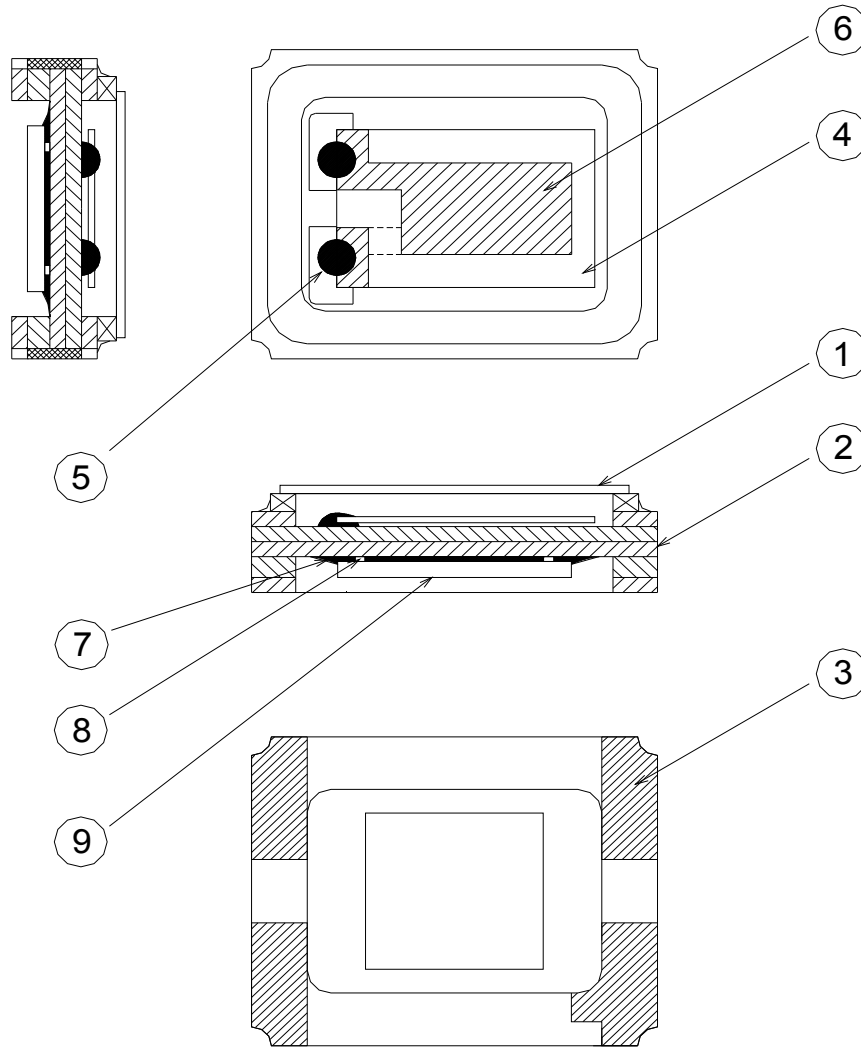

No.	COMPONENTS	MATERIALS	FINISH/SPECIFICATIONS
1	Cap	Metal(Fe + Co + Ni)	-
2	Base	Ceramic	Color Black
3	Pad	Au	Molybdenum Metalize + Ni Plating + Au Plating
4	Crystal Blank	SiO ₂	-
5	Conductive Adhesive	Ag	Silicone Resin
6	Electrode	Noble Metal	-
7	Underfill	Organic	Color Black
8	Bump	Au	
9	IC	Si	

■ RELIABILITY SPECIFICATIONS

1. Mechanical Endurance

No.	Test Item	Test Methods	Criteria
1.1	Drop Test	Height : 100 cm height Direction : X,Y,Z 6 directions Test cycles : 3 cycles Fall freely on to concrete floor Mounting on test fixture (total weight=100 g)	+/- 2.0 ppm
1.2	Mechanical Shock	Acceleration : 1000 g Duration : 0.5 ms Test cycles : 3 times for all 3 directions	+/- 2.0 ppm
1.3	Vibration	Frequency range : 10 ~ 2000 Hz Amplitude : 1.52 mm (10 ~ 80 Hz) Acceleration : 20 g (80 ~ 2000 Hz) Sweep speed : 20 minutes/cycle Direction : X,Y,Z 3 directions Duration : 4 hours/each direction	+/- 2.0 ppm
1.4	Gross Leak	Standard sample for automatic gross leak detector. Test Pressure : 2 kg/cm ²	< 1.5 × 10 ⁻⁵ Pa m ³ / sec
1.5	Fine Leak	Helium bombing 4.5 kgf/cm ² for 2 hours	< 1.0 × 10 ⁻⁹ Pa m ³ / sec
1.6	Solderability	Preheate temperature : 125°C ± 5°C Preheate time : 120 sec Soldering temperature : 245°C ± 5 °C Duration : 5 ± 1 sec Method : Solder bath method	90% Coated

[Note] Criteria mean the maximum frequency change after reliability test, frequency measured at 25°C.

2. Environmental Endurance

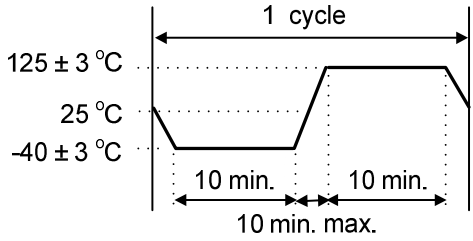
No.	Test Item	Test Methods	Criteria
2.1	High Temp. Storage	Temperature : +125°C ± 3°C Duration : 168 hours	+/- 2.0 ppm
2.2	Low Temp. Storage	Temperature : -40°C ± 3°C Duration : 500 hours	+/- 2.0 ppm
2.3	Thermal Shock (Air to Air)	Total 100 cycles of the following temperature cycle : 	+/- 2.0 ppm
2.4	High Temp & Humidity	Temperature : 85°C ± 3°C Humidity: RH 85% Duration : 168 hours	+/- 2.0 ppm
2.5	Aging	Temperature : 85°C ± 3°C Duration : 500 hours Voltage input by specification	+/- 2.0 ppm

[Note] Criteria mean the maximum frequency change after reliability test, frequency measured at 25°C.