



REV.	ECN NO.	REVISED	DATE

NOTE:

1.MATERIAL:

- a.HOUSING:PPA
- b.CONTACT:PHOSPHOR BRONZE  
(SURFACE PLATING: Au1u")

SEE ORDERING INFORMATION

2.ELECTRIC:

- a.CONTACT RESISTANCE: 30 MILLIOHMS MAX
- b.INSULATION RESISTANCE: 1000 MEGA OHMS MIN
- c.DIELECTNIC VOLTAGE: 500V AC ONE SEC LEVEL
- d.OPERATING TEMPERATURE: -25° C~ +85° C

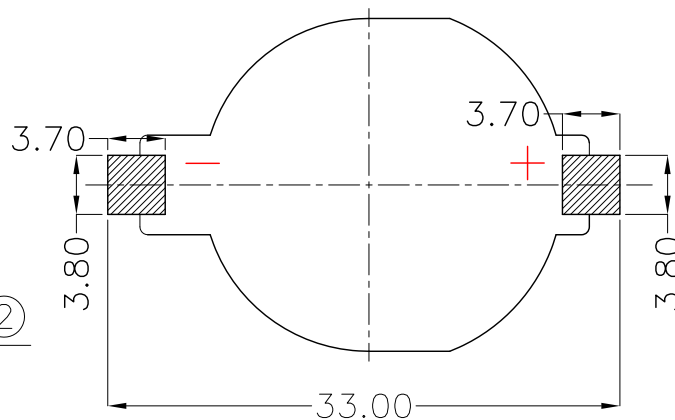
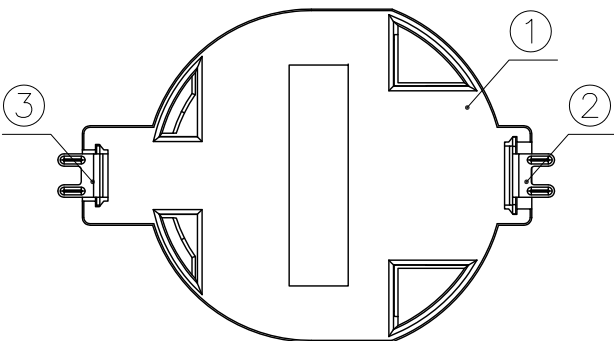
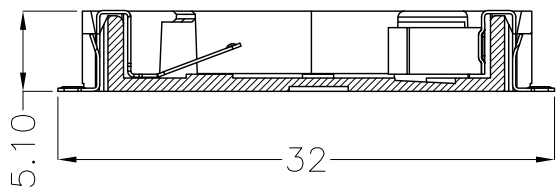
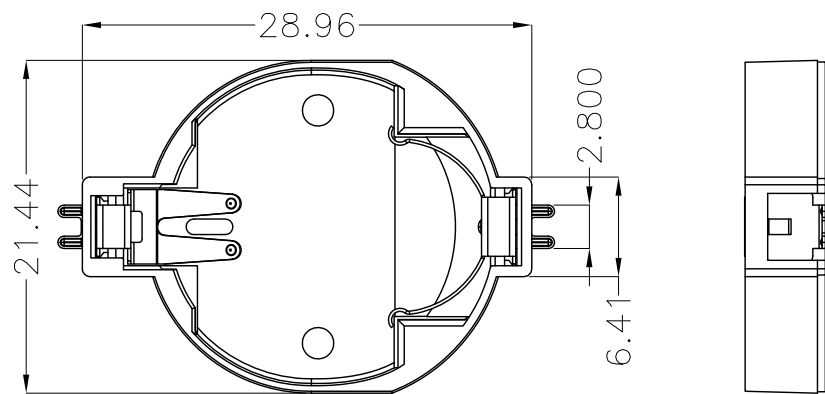

PCB Layout Diagram  
Top View

ORDERING INFORMATION

BS-10-B\*\*\*010

电池座系列

BS-10系列

SMT 180° TYPE

PLATING:  
A-Au1U"  
J-Ni100U"~120U"  
K-Sn100U"~120U"

MATERIAL:  
1A-PBT BLACK  
1B-PA66 BLACK  
2A-PPA BROWN  
2B-PPA BLACK  
3A-PPS BROWN  
3B-PPS BLACK  
4A-LCP WHITE  
4B-LCP BLACK

工程部  
2018-12-20  
LQ. HUANG

UNLESS OTHERWISE SPECIFIED TOLERANCES

**MYOUNG 美阳** www.meiyangdz.com

DECIMALS: X :±0.30 X.X :±0.25 X.XX :±0.20 X.XXX :±0.10  
ANGLES: X :±1° X.X :±0.5°

DSND	YangFeng	DATE	2018-12-20	TITLE:	
CHKD	ZhouRuicai	DATE	2018-12-20	BS-2032-10 Sony PPA SMT	
APVD	XueShunyong	DATE	2018-12-20	PART NO.:	
WEIGHT:	1.21g	SCALE:	2:1	SIZE:	A4
SHEET	1 OF 1	UNIT:	mm	REV.:	A/0
		VIEW:	⊙ ⊞	OBJECT:	MY
				DRAW NO.:	MY-CP-0178

NO.	PART NAME	Q'TY	MATERIAL	PLATING & COLOR
3	TERMINAL(-)	1	PHOSPHOR BRONZE, T=0.20mm	Gold Plating and Ni Under-Plating
2	TERMINAL(+)	1	PHOSPHOR BRONZE, T=0.20mm	Gold Plating and Ni Under-Plating
1	HOUSING	1	PPA	BROWN

