

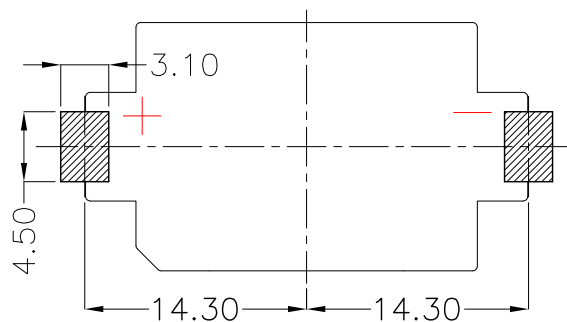

REV.	ECN NO.	REVISED	DATE

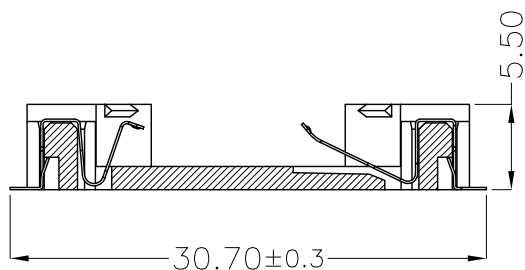

PCB Layout Diagram  
Top View

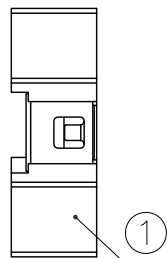
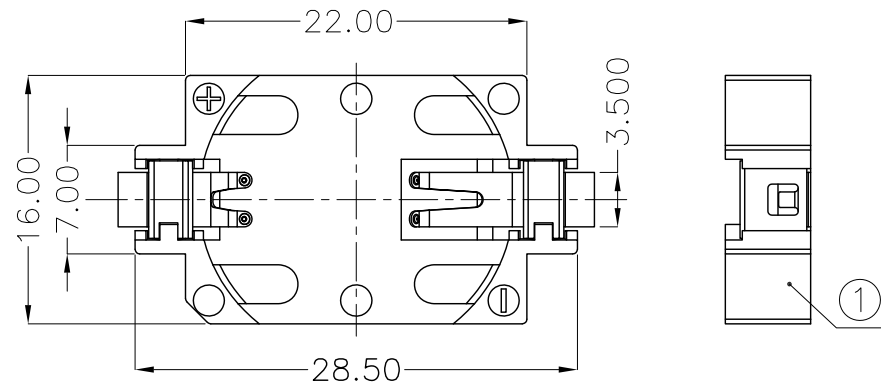
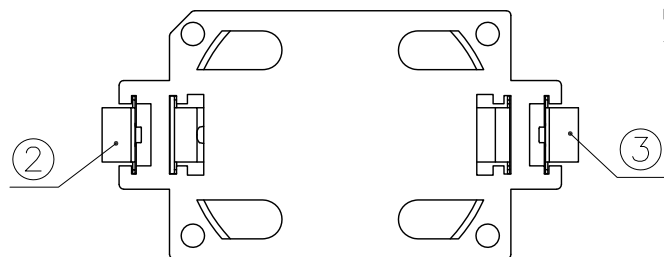

1.MATERIAL:  
a.HOUSING:LCP  
b.CONTACT:PHOSPHOR BRONZE  
(SURFACE PLATING: Au1u")  
SEE ORDERING INFORMATION

2.ELECTRIC:  
a.CONTACT RESISTANCE: 30 MILLIOHMS MAX  
b.INSULATION RESISTANCE: 1000 MEGA OHMS MIN  
c.DIELECTNIC VOLTAGE: 500V AC ONE SEC LEVEL  
d.OPERATING TEMPERATURE: -25°C~ +85°C

ORDERING INFORMATION

BS-06-B\*\*\*012

电池座系列

BS-06系列

SMT 180° TYPE

PLATING:  
A-Au1U"  
J-Ni100U"~120U"  
K-Sn100U"~120U"

MATERIAL:  
1A-PBT BLACK  
1B-PA66 BLACK  
2A-PPA BROWN  
2B-PPA BLACK  
3A-PPS BROWN  
3B-PPS BLACK  
4A-LCP WHITE  
4B-LCP BLACK  
5A-PA6T WHITE  
5B-PA6T BLACK



NO.	PART NAME	Q'TY	MATERIAL	PLATING & COLOR
3	TERMINAL(-)	1	PHOSPHOR BRONZE, T=0.15mm	Gold Plating and Ni Under-Plating
2	TERMINAL(+)	1	PHOSPHOR BRONZE, T=0.15mm	Gold Plating and Ni Under-Plating
1	HOUSING	1	LCP	WHITE

UNLESS OTHERWISE SPECIFIED TOLERANCES		<b>MYOUNG 美阳</b> <a href="http://www.meiyangdz.com">www.meiyangdz.com</a>	
DECIMALS: X :±0.30 X.X :±0.25 X.XX :±0.20 X.XXX :±0.10	ANGLES: X :±1° X.X :±0.5°	DSND YangFeng	DATE 2017-07-11
WEIGHT: 1.49g		CHKD ZhouRuicai	DATE 2017-07-11
SHEET 1 OF 1		APVD XueShun Yong	DATE 2017-07-11
UNIT: mm	REV.: A/0	SCALE: 2:1	VIEW:
		SIZE: A4	

TITLE:  
BS-2032-6 Au SMT 短脚  
PART NO.:  
BS-06-B4AA012  
DRAW NO.:MY-CP-0164