

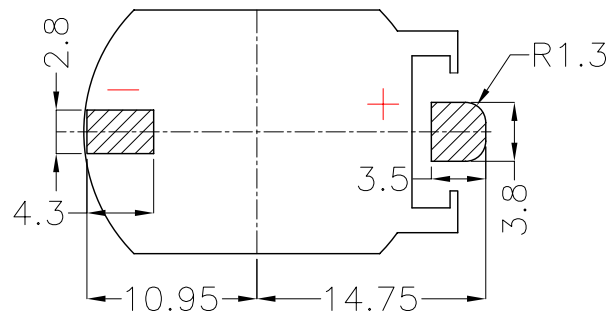

REV.	ECN NO.	REVISED	DATE

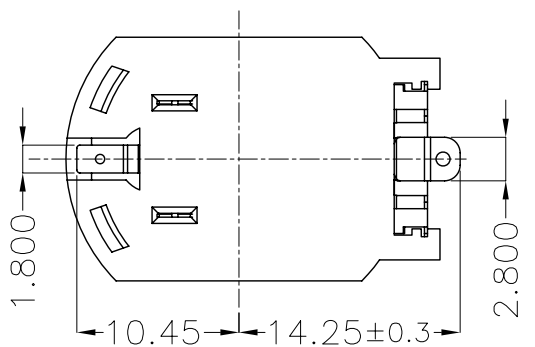
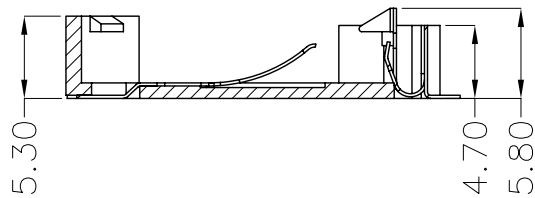
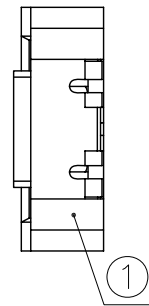
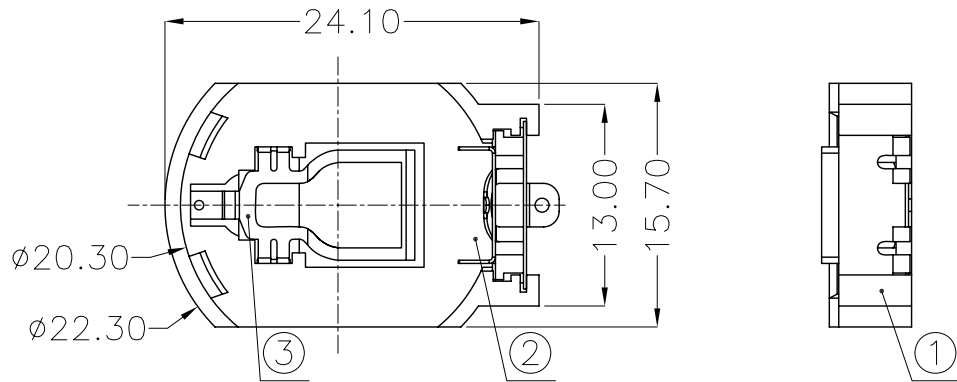

PCB Layout Diagram
Top View

NOTE:

1.MATERIAL:

- a.HOUSING:PPA
- b.CONTACT:PHOSPHOR BRONZE
(SURFACE PLATING: Au1U")

SEE ORDERING INFORMATION

2.ELECTRIC:

- a.CONTACT RESISTANCE: 30 MILLIOHMS MAX
- b.INSULATION RESISTANCE: 1000 MEGA OHMS MIN
- c.DIELECTNIC VOLTAGE: 500V AC ONE SEC LEVEL
- d.OPERATING TEMPERATURE: -25°C~ +85°C

ORDERING INFORMATION

BS-08-B***008

电池座系列

BS-08系列

SMT 180° TYPE

- A-Au1U"
- J-Ni100U"~120U"
- K-Sn100U"~120U"
- L-Ni150U"- Sn80U"

- MATERIAL:
- 1A-PBT BLACK
 - 1B-PA66 BLACK
 - 2A-PPA BROWN
 - 2B-PPA BLACK
 - 3A-PPS BROWN
 - 3B-PPS BLACK
 - 4A-LCP WHITE
 - 4B-LCP BLACK



UNLESS OTHERWISE SPECIFIED TOLERANCES		MYOUNG 美阳 www.meiyangdz.com	
DECIMALS: X :±0.30 X.X :±0.25 X.XX :±0.20 X.XXX :±0.10	ANGLES: X :±1° X.X :±0.5°	DSND YangFeng	DATE 2017-06-30
		CHKD ZhouRuicai	DATE 2017-06-30
		APVD XueShunyong	DATE 2017-06-30
WEIGHT: 0.92g		SCALE: 2:1	SIZE: A4
SHEET 1 OF 1		VIEW:	REV.: A/0
		UNIT: mm	OBJECT: MY
		TITLE: BS-2032-8KG SMT	
		PART NO.: BS-08-B2AA008	
		DRAW NO.:MY-CP-0077	

NO.	PART NAME	Q'TY	MATERIAL	PLATING & COLOR
3	TERMINAL(-)	1	PHOSPHOR BRONZE, T=0.20mm	Gold Plating and Ni Under-Plating
2	TERMINAL(+)	1	PHOSPHOR BRONZE, T=0.25mm	Gold Plating and Ni Under-Plating
1	HOUSING	1	PPA	BROWN