

REVISION RECORD				
REV	ECN	DESCRIPTION	DRFT	DATE

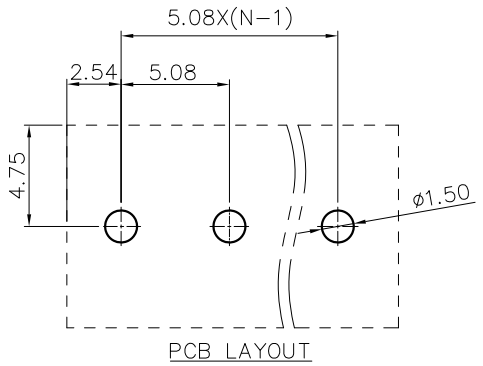
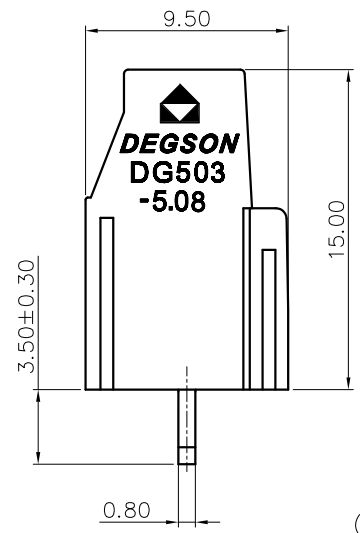
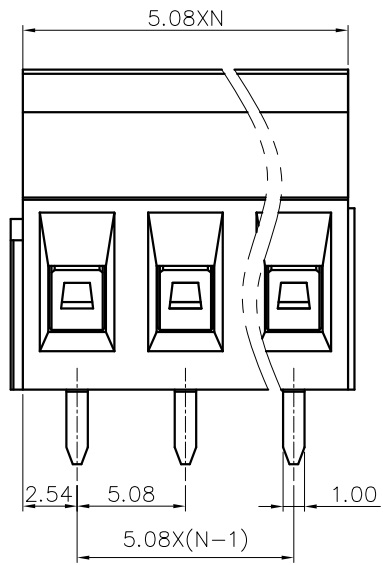
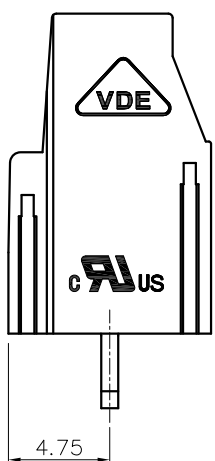
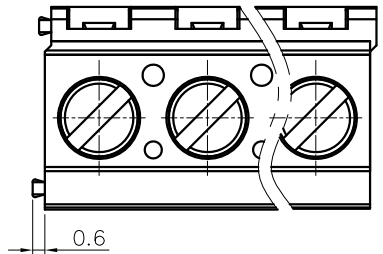

NOTES1:
 UL Standard
 1.Rated Voltage/Current : 300V / 20A
 2.Torque Value : M3 , 4.43Lb.in
 3.Wire Range : 28~12AWG

IEC Standard
 1.Rated Voltage/Current : 450V / 20A
 2.Torque Value : M3 , 0.5N.m
 3.Wire Range : 0.2~2.5mm²

NOTES2:
 1.Dimension shall be interpreted per ASME Y14.5-2009
 2.Pitch : 5.08mm, Poles : N=2~12P
 3.Stripping length : 6~7mm
 4.Withstanding Voltage : AC2500V/1Min.
 5.Operating temperature : -40°C~+105°C
 6.Undimensioned Tolerances:

Pitch range in mm		Nominal dimension range in mm					
TO	Over TO	TO	Over TO	Over TO	Over TO	0.1/10	
6	10	30	60	100	150		
±0.15	±0.20	±0.30	±0.50	±0.70	±1.00	±1.30	±2°

7.RoHS Compliance

DG503 - 5.08 - XXP - 1Y - 00A (H)
 (Series No.) (Pitch) (Poles) (Single Pitch) (Color):1.(Grey)
 2.(Blue)
 3.(Black)
 4.(Green)
 5.(Orange)
 6.(Red)
 7.(Transparent)
 8.(Yellow)
 9.(White)

DETACHED LISTS	PART NO.:	NINGBO DEGSON ELECTRICAL CO., LTD			
	APPD:	NAME: DG503-5.08-XXP-1Y-00A(H)			
	CHKD:	TITLE: CUSTOMER DRAWING			
	DRFT:	DRAWING NO.:		REV	DO
	THIRD ANGLE PROJECTION		MM (INCH)	DO NOT SCALE DRAWING	SCALE 1:1