



SK3410

Band41, RF SAW Filter
Revision 0 : January 2017

MSL 3 Device



- Electrical Characteristics
 - Package Dimensions
 - Testing Environment
 - Frequency Characteristics
-

□ Electrical Characteristics

Maximum Ratings

Parameters Description	Unit	Minimum	Typical	Maximum
Operating Temperature Range	°C	-20	-	+85
Storage Temperature Range	°C	-40	-	+85
Maximum DC Voltage	V	3V (25±2 deg.C)		
Maximum Input Power	dBm	28.5dBm, 5000h 55 deg.C		
Source Impedance (Unbalance) ⁽¹⁾	Ω	-	50	-
Load Impedance (Unbalance) ⁽¹⁾	Ω	-	50	-
Package type & size	C24			
Length x Width	mm ²	-	1.4 x 1.1	-
Height	mm	-	-	0.65

Electrical Specification

Parameters Description	Unit	Minimum	Typical	Maximum	Remarks
Center Frequency (Fo)	MHz	-	2605.0	-	-
Insertion Loss within 2555.0 ~ 2575.0 MHz	dB	-	2.4	4.0	-
2575.0 ~ 2635.0 MHz	dB	-	1.6	2.5	-
2635.0 ~ 2655.0 MHz	dB	-	1.3	2.5	-
Amplitude Ripple within 2555.0 ~ 2655.0 MHz	dB _{p-p}	-	1.5	2.8	-
Attenuation:					
10.0 ~ 960.0 MHz	dB	40	52	-	-
1225.0 ~ 1559.0 MHz	dB	30	39	-	-
1559.0 ~ 1606.0 MHz	dB	30	38	-	-
1606.0 ~ 1710.0 MHz	dB	30	35	-	-
1710.0 ~ 2170.0 MHz	dB	27	31	-	-
2170.0 ~ 2400.0 MHz	dB	27	31	-	-
2401.0 ~ 2438.0 MHz	dB	33	36	-	-
2421.0 ~ 2483.0 MHz	dB	35	37	-	-
2750.0 ~ 4900.0 MHz	dB	30	34	-	-
4900.0 ~ 6000.0 MHz	dB	30	36	-	-
6000.0 ~ 8000.0 MHz	dB	25	35	-	-
VSWR within 2555.0 ~ 2655.0 MHz	-	-	1.7	2.2	-

Notes : (1) With Matching Network (Ref. Testing Environment Circuit as shown below).

□ Package Dimensions

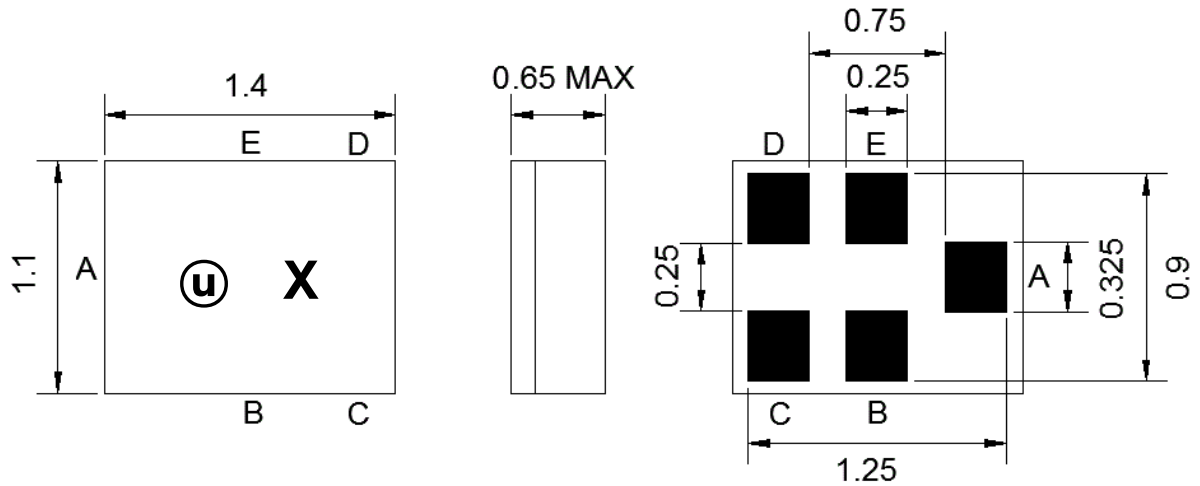

Marking Descriptions	
Ⓢ	Series Number
X	Date Code(Year+Month)

Pin Description	
B, C, E	Ground
A	Input
D	Output

□ Testing Environment

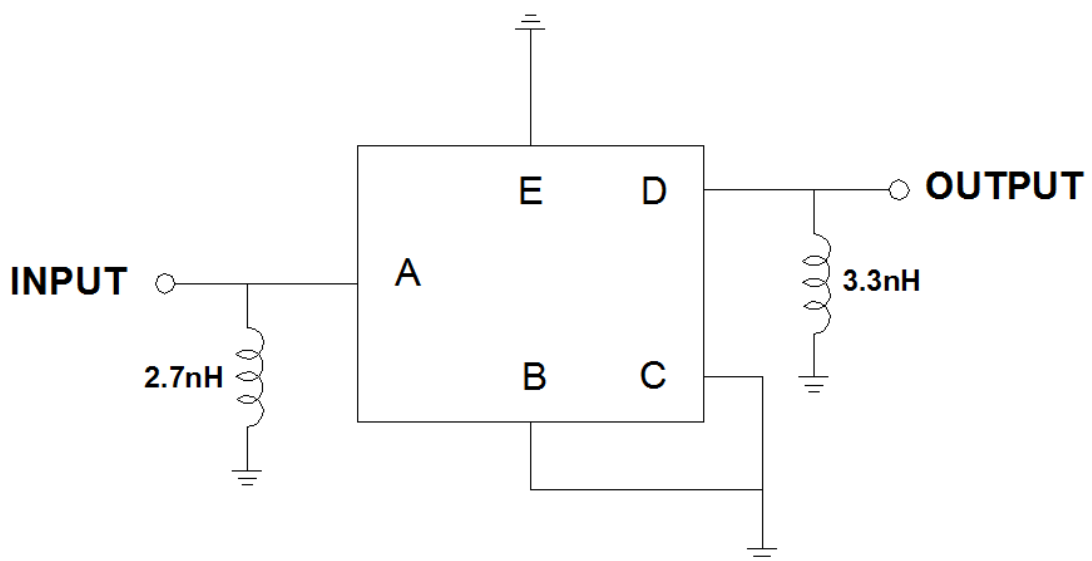

Source & Load Impedance: 50 Ω

□ Frequency Characteristics

Frequency Response

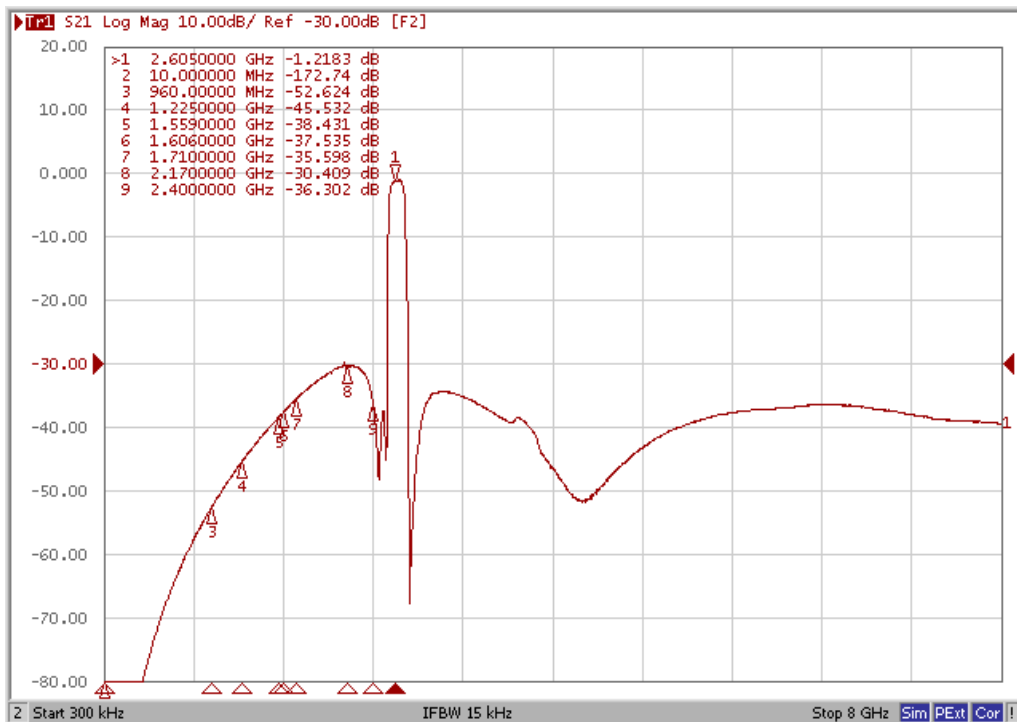
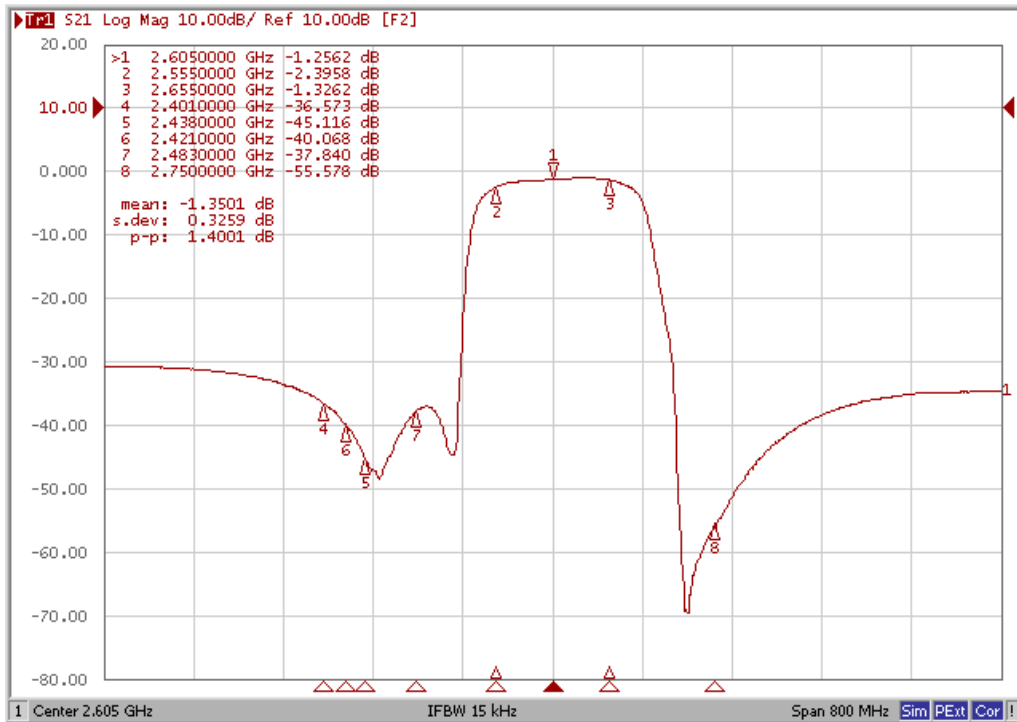

VSWR

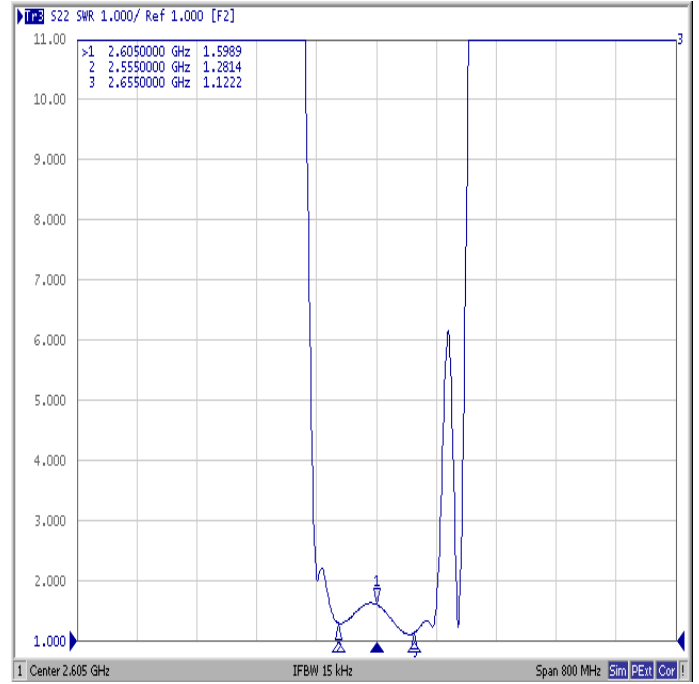
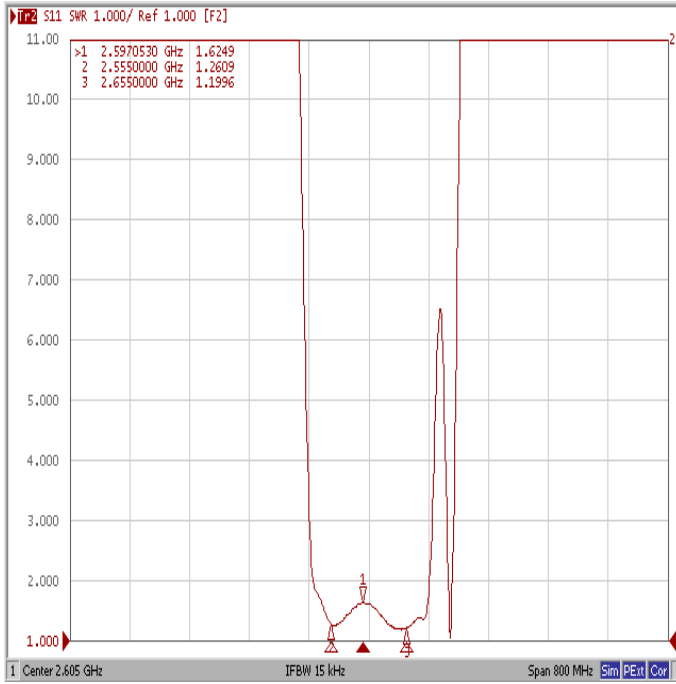

Smith Chart

