

## Parts Drawing

## REVISIONS

SYM	ECN No.	MODIFICATION	DATE	ISSUED

## Note:

## 1.Material:

- 1.1,Housing: High temperature thermoplastic with/black G/F,UL94v-0
- 1.2,Contact: copper alloy,t=0.25mm
- 1.3,Shell: copper/Ferroalloy alloy,t=0.30mm

## 2.Specification:

- 2.1,Current rating:3A/5A Max.
- 2.2,Dielectric withstanding voltage: 100 V(ac) for 1 min.
- 2.3,Contact resistance: 30 mΩ Max.
- 2.4,Insulation resistance: 100 MΩ Min.
- 2.5,Total mating force: 3.57 Kgf Max.
- 2.6,Total unmating force: 1.0 Kgf Min.

## 3.Finish:

- 3.1,Contact: Plated Golg in Mating Area:  
Tin On Solder Talls  
Shell: Nickel Plating

## 4.Environmental:

- 4.1,Temperature range: -55°C~85°C



## PART ON:

919-55XXXXX1Y2XX

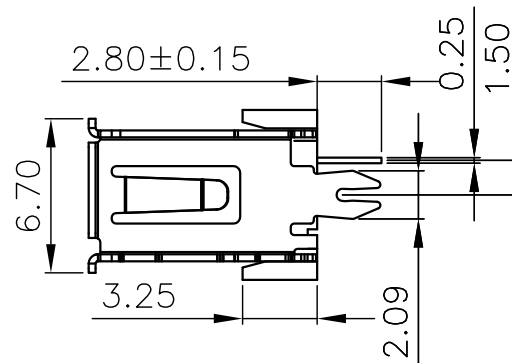
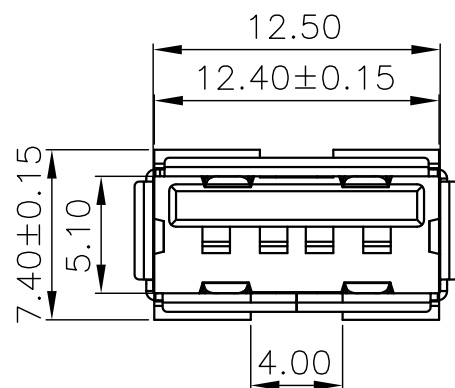
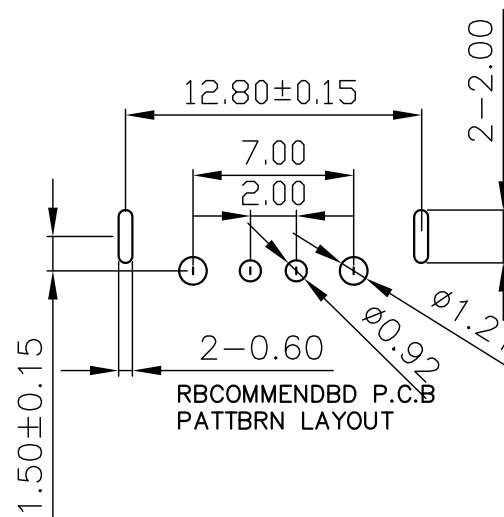
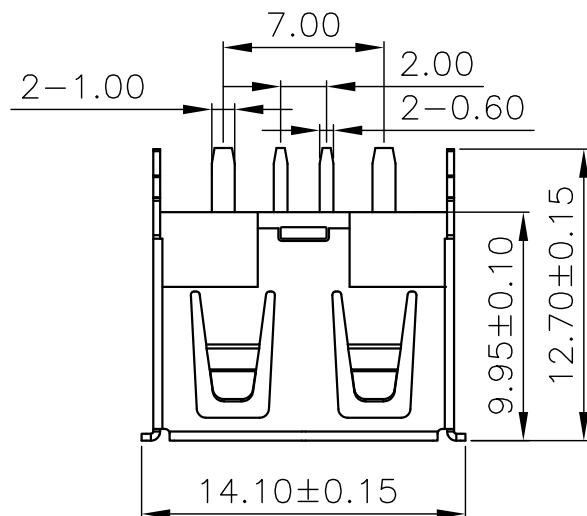
- 电镀规格: 02,镀金1u" 04,镀金3u"  
07,镀金15u" 08,镀金30u"
- 端子材质: 1,青铜 2,磷铜
- 端子规格: D,90度 Y,180度 S,SMT贴板
- 塑胶形态: 1,6.2有耳 6,6.2无耳
- 塑胶颜色: 01,白色 02,黑色 03,本色
- 塑胶材质: 1,PBT 2,LCP 3,PA9T 4,PPA 5,PA6T
- 对插方向: A,正向 B,反向
- 外壳材质: 1,铁壳 2,铜壳
- 插口类型: 5,有边 6,无边
- 外壳脚型: 1,前两脚 2,后两脚 3,四脚  
4,无脚 5,鱼叉脚
- 类别: E款



1	919-551A1011Y102	5	
2		6	
3		7	
4		8	

DRAWN		 深圳市精拓金电子有限公司						
CHECKED						TITLE	PART NO.	
APPROVED						AF大电流10.0短体180度鱼叉脚有边铜壳PBT白胶	916-352A1014Y10210	
		UNIT	TOLERANCE	SCALE	SHEET	SIZE	REV.	
		mm	.XXX±.10, .XX±.25, .X±.38, ANG±5°	1:1	1 OF 1	A4	X1	
		DRAWING NO.		R919551A1011Y102				