

# 零件承认书

SPECIFICATION FOR APPROVAL

客户名称: \_\_\_\_\_

客户料号: \_\_\_\_\_

增益料号: AL0410-102K-LSBD

规格描述: 色码电感 0410 1.0mH±10%

日期: 2021/2/25

版本: A1

增益签核:

制订	审核	核准
张翔	刘业明	柯文学

客户签核:

工程	审核	核准



东莞市增益实业有限公司

地址: 东莞市塘厦镇林村塘厦大道北552号1-911

电话: 0769-87321000

传真: 0769-87891229

物料类型:

色码电感

日期:

2021/2/25

版本:

A1

# 图面规格变更履历表

客户		0	料号		品名	
客户版本	增益版本	变更内容	日期	制定	审核	核准
	A	初版	2021/2/25	张翔	刘业明	柯文学
 <p><b>东莞市增益实业有限公司</b></p> 地址：东莞市塘厦镇林村塘厦大道北552号1-911 电话：0769-87321000 传真：0769-87891229				物料类型：	色码电感	
				日期：	2021/2/25	
				版本：	A1	

**东莞市增益实业有限公司**  
**Dongguan ZengYi Industrial Co., LTD.**

---

CUSTOMER		FULL	
MODEL No.		APPROVED	
PART No.	AL0410-102K-LSBD	CONDITIONAL	
DATE	2021-2-25	APPROVED	
REVISION No.	A1.0	REJECTED	

**< INDEX >**

---

1. SHAPE & DIMENSION	P1
2. ELECTRICAL SCHEMATICS	P1
3. ELECTRICAL SCHEMATICS & TEST INSTRUMENTS	P2
4. MATERIAL LIST	P2
5. TEST DATA FOR PREPRODUCTION SAMPLES	P3
6. RELIABILITY TEST METHOD	P4-5

---

	APPROVED BY	
	CHECKED BY	
	MADE BY	

Tel: 0769-87321000

Fax: 0769-87891229

地址: 东莞市塘厦镇林村塘厦大道北 552 号

**东莞市增益实业有限公司**  
**Dongguan ZengYi Industrial Co., LTD.**

CUSTOMER		MADE	
MODEL No.		DATE	2021-2-25
PART No.	AL0410-102K-LSBD	PAGE	1
DESCRIPTION	FIXED INDUCTORS	REVISION	A1.0

1、SHAPE & DI

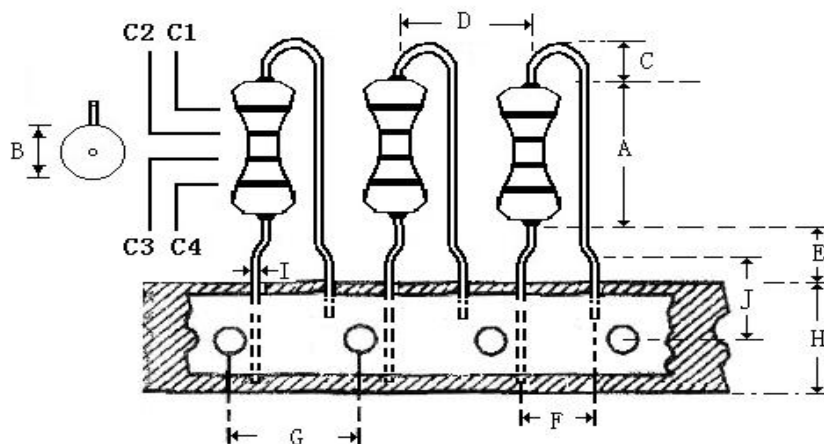

C1	棕色	C2	黑色	C3	红色	C4	银色
A	10.0MAX	D	13.5±1.0	G	12.7±0.5	J	18.0±2.0
B	5.0MAX	E	12.0MAX	H	18.0±1.0		
C	2.5MAX	F	5.0±0.5	I	0.6±0.1		

2. ELECTRICAL SCHEMATICS

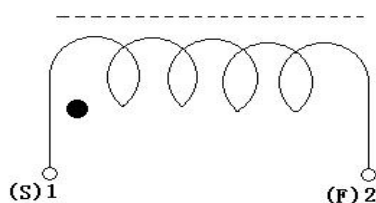

Tel: 0769-87321000

Fax: 0769-87891229

地址: 东莞市塘厦镇林村塘厦大道北 552 号

**东莞市增益实业有限公司**  
**Dongguan ZengYi Industrial Co., LTD.**

CUSTOMER		MADE	
MODEL No.		DATE	2021-2-25
PART No.	AL0410-102K-LSBD	PAGE	2
DESCRIPTION	FIXED INDUCTORS	REVISION	A1.0

**3.ELECTRICAL SPECIFICATION & TEST INSTRUMENTS**

MEAS. ITEM	L	Q	DCR	RatedDCCurrent	
UNIT	mH		Ω	mA	
SPEC	1.0±10%	40Min	14Max		
TEST FREQ	0.252MHz/1V	0.796MHz/1V			
TEST STRUMENTS	HP-4285A	HP-4285A	502BC		

**4.MATERIAL LIST**

No	ITEM	Material		Vendor	Rating	UL File	ROHSstate
1	CORE	FC1 3×6	FCI	HENGCI	150℃		Yes
2	WIRE WINDING	2UEW Φ0.07mm	TURNS:248 Ts (REF)	HOILUEN	130℃	EI64409	Yes
3	EPOXY RESIN	NC-G		homeTown	200℃		Yes
4	PNI	Φ0.6	CP	BAI CHUAN	130℃		Yes

或同等材质供应商

※REMARK※

Tel: 0769-87321000

Fax: 0769-87891229

地址: 东莞市塘厦镇林村塘厦大道北 552 号

**东莞市增益实业有限公司**  
**Dongguan ZengYi Industrial Co., LTD.**

CUSTOMER		MADE	
MODEL No.		DATE	2021-2-25
PART No.	AL0410-102K-LSBD	PAGE	3
DESCRIPTION	FIXED INDUCTORS	REVISION	A1.0

**5. TEST DATA FOR PREPRODUCTION SAMPLE**

MEAS.ITEM	L (mH)	Q	DCR ( $\Omega$ )
SPEC	1.00 $\pm$ 10%	40MIN	14.0MAX
1	1.01	60	11.4
2	1.01	61	11.1
3	0.99	58	11.5
4	1.01	58	11.5
5	1.02	63	11.8
6	1.01	62	11.5
7	1.00	57	11.8
8	1.01	62	11.4
9	1.03	58	11.6
10	1.01	60	11.4
$\bar{x}$			
R			
YOUR SAMPLE			

TEST CONDITION:                      TEMP:                      25°C(REF.)                      R.H.:                      60%(REF.)

Tel: 0769-87321000

Fax: 0769-87891229

地址: 东莞市塘厦镇林村塘厦大道北 552 号

**东莞市增益实业有限公司**  
**Dongguan ZengYi Industrial Co., LTD.**

CUSTOMER		MADE	
MODEL No.		DATE	2021-2-25
PART No.	AL0410-102K-LSBD	PAGE	4
DESCRIPTION	<b>FIXED INDUCTORS</b>	REVISION	A1.0

## 6.RELIABILITY TEST METHOD

### 6-1. MECHANICAL

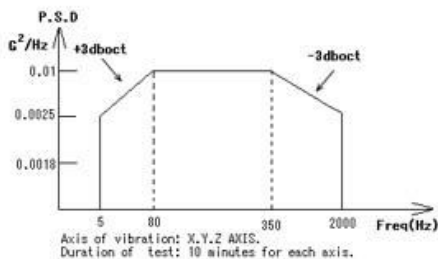
TEST ITEM	SPECIFICATION	TEST DETAILS
Terminal pull strength	9.8(N)MIN	A pulling load should be gradually applied to the leads in a downward direction and should be monitored the value at the point of destroy.
Terminal bending strength	1CYCLE MIN	A specified load of 4.9(N) should be suspended, From the terminal then slowly inclined the 90°C, and then return to normal position ,The consecutive bends shall be done in the opposite directions.(Total 1 cycle)
Dropping	$\Delta L/L0 \leq \pm 5\%$ $\Delta Q/Q0 \leq \pm 20\%$ There is no evidence of any mechanical failures	The sample shall be dropped on a concrete floor once from 1 meter height (39 inches) Total 3 cycles.
Vibration	$\Delta L/L0 \leq \pm 5\%$ $\Delta Q/Q0 \leq \pm 20\%$ There is no evidence of any mechanical failures	 <p>Axis of vibration: X,Y,Z AXES. Duration of test: 10 minutes for each axis.</p>
Resistance to soldering heat	There is no evidence of any mechanical failures	The sample should be immersed to a depth of 1.5mm below the lower core surface into solder at a temperature of 260°C (+10,-0)for a duration of 5seconds(+1,-0).

### 6-2.ELECTRICAL

TEST ITEM	SPECIFICATION
Insulation Resistance	The insulation resistance between core to coil is over 100MΩ at500V, 3SEC.
Withstand Voltage	Apply AC 500V between core to coil for one minute there shall not be any abnormality.

Tel: 0769-87321000

Fax: 0769-87891229

地址: 东莞市塘厦镇林村塘厦大道北 552 号

**东莞市增益实业有限公司**  
**Dongguan ZengYi Industrial Co., LTD.**

CUSTOMER		MADE	
MODEL No.		DATE	2021-2-25
PART No.	AL0410-102K-LSBD	PAGE	5
DESCRIPTION	FIXED INDUCTORS	REVISION	A1.0

**6-3.ENVIRONMENT CHARACTERISTICS**

TEST ITEM	SPECIFICATION	TEST DETAILS
High temperature storage	$\Delta L/L0 \leq \pm 5\%$ $\Delta Q/Q0 \leq \pm 25\%$ There is no evidence of any mechanical failures	The coil should be stored at an ambient temperature of $+85 \pm 2^\circ\text{C}$ for 72 hours ,after which the measurement should be made.
Low temperature storage	$\Delta L/L0 \leq \pm 5\%$ $\Delta Q/Q0 \leq \pm 25\%$ There is no evidence of any mechanical failures	The coil should be stored at an ambient temperature of $-40 \pm 2^\circ\text{C}$ for 500 hours ,after which the measurement should be made.
Thermal shock	$\Delta L/L0 \leq \pm 5\%$ $\Delta Q/Q0 \leq \pm 30\%$ There is no evidence of any mechanical failures	
Humidity life test	$\Delta L/L0 \leq \pm 5\%$ $\Delta Q/Q0 \leq \pm 30\%$ There is no evidence of any mechanical failures	The rated current shall be applied to the coil at an ambient temperature $+40 \pm 2^\circ\text{C}$ with relative humidity of 90% for 1000 hours.

**6-4.SAFETY**

TEST ITEM	SPECIFICATION	TEST DETAILS
Over load test	No abnormal smoking or fire	The twice current of the rated dc current should be applied to the coil for 5 min

Tel: 0769-87321000

Fax: 0769-87891229

地址: 东莞市塘厦镇林村塘厦大道北 552 号