

REV.	版本号	日期	姓名	日期
A0	△新版发行		冯国俊	2020-10-20

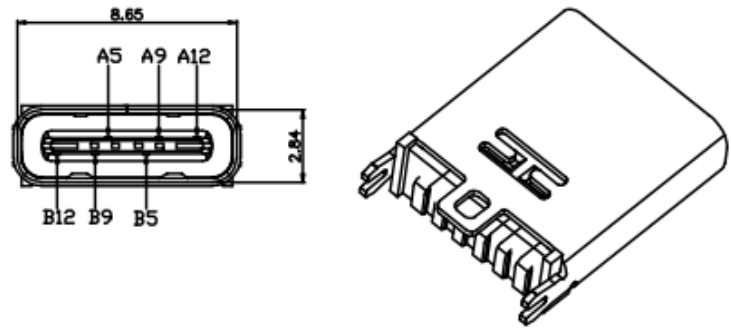

B12	GND
B9	VBUS
B5	CC2
A5	CC1
A9	VBUS
A12	GND
PIN	SIGNAL NAME

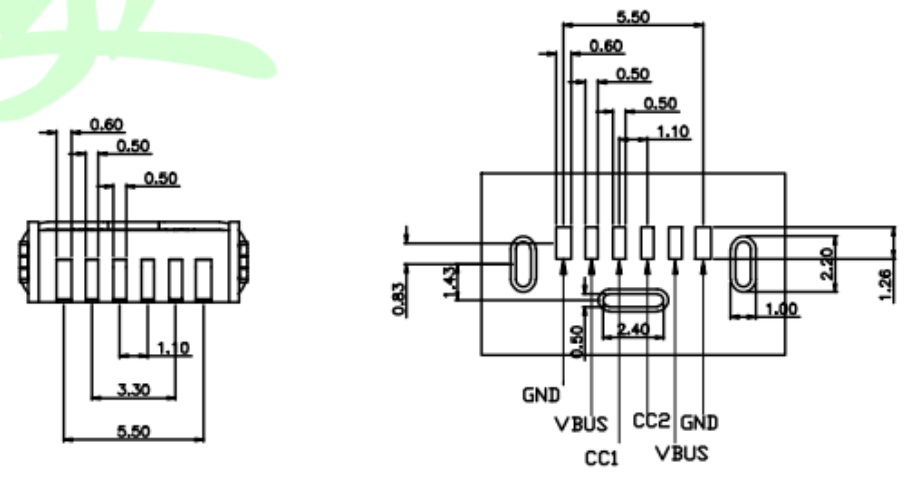
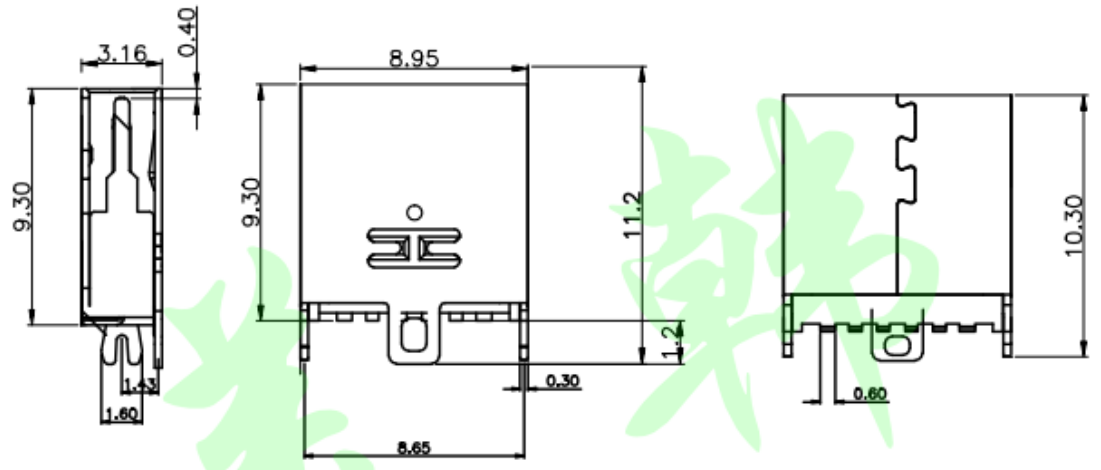

NOTES:

- 1.MATERIAL:  
MOLDING: LCP UL94 V-0  
CONTACT:COPPER ALLOY.  
GOLD PLATED Min ON CONTACT AREA,100u"  
Min TIN (LEAD FREE) ON SOLDER AREA,  
SHELL: SUS201-H,T=0.30±0.03mm  
50u" NICKEL PLATING OVER ALL.
- 2.MECHANICAL:  
INSERTION: 5~20N.  
EXTRACTION: 8~20N AFTER TEST.  
DURABILITY: 5000 CYCLES
- 3.ELECTRICAL:  
CURRENT: 3A FOR VBUS;  
1.25A FOR GND PIN.  
0.25A FOR OTHER.  
VOLTAGE: 20 V MAX  
WITHSTANDING VOLTAGE: 100V AC R.M.S.  
CONTACT RESISTANCE: 40mΩ MAX.  
INSULATION RESISTANCE: 100MΩ MIN.
- 4.ENVIRONMENTAL  
TEMPERATURE RANGE -25°C ~ +85°C
5. 尺寸标注事项:  
图示有标注⊕者为首样全检,重点管控尺寸.
6. 产品符合RoHS标准

东莞市美韩电子科技有限公司  
Dongguan Usakro Electronic Technology Co., Ltd.

.X: ±0.35	.X': ±1.5'	DESIGN CODE: CONNECTOR	TITLE: TYPE C 6PIN PLUG 简易版立贴直插9.3	
.XX: ±0.25	.XX': ±1.0'		PART NO.:	SEE TABLE
.XXX:±0.20	.XXX':±0.5'	APP.:	DR. NO.:	TYPE-C-6M-011-093
MAT'L: SEE NOTES		CRD.:	SCALE:	1:1
FINISH:		DR.:	Len.Song	PAGE: 1/1
			UNIT:	mm
			REV.:	A0