

### Features

- ◆ Transient protection for data lines to  
**IEC 61000-4-2 (ESD)  $\pm 20\text{kV}$  (air),  $\pm 20\text{kV}$  (contact)**  
**IEC 61000-4-4 (EFT) 40A (tp = 5/50ns)**  
**Cable Discharge Event (CDE)**
- ◆ Protects one data or I/O line
- ◆ Low capacitance: **0.35pF**
- ◆ Low clamping voltage
- ◆ Low operating voltage: 3.3V
- ◆ Solid-state silicon-avalanche technology

### Mechanical Characteristics

- ◆ Package: DFN1006-2
- ◆ Lead Finish: Matte Tin
- ◆ UL Flammability Classification Rating 94V-0
- ◆ Pb-Free, Halogen Free, RoHS/WEEE Compliant

### Applications

- ◆ Cellular Handsets & Accessories
- ◆ Digital Visual Interface (DVI)
- ◆ Display Port
- ◆ MDDI Ports
- ◆ USB Ports
- ◆ PCI Express
- ◆ Serial ATA

### Ordering Information

Part Number	Qty per Reel	Reel Size
TPESD3301P	10000	7"

### Dimensions and Pin Configuration

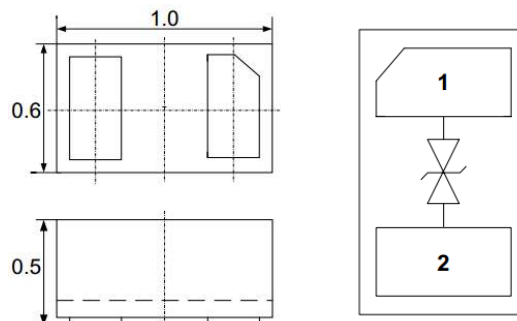

**Marking: 1**

**Absolute Maximum Ratings ( $T_A=25^\circ\text{C}$  unless otherwise specified)**

Parameter	Symbol	Limits	unit
IEC61000-4-2(ESD) Contact Air	$V_{\text{ESD}}$	$\pm 20$ $\pm 20$	KV
Peak Pulse Power (8/20us)	$P_{\text{pk}}$	80	W
Peak Pulse Current (8/20us)	$I_{\text{pp}}$	4	A

**Electrical Characteristics ( $T_A=25^\circ\text{C}$  unless otherwise specified)**

Symbol	Parameter
$V_{\text{RWM}}$	Nominal Reverse Working Voltage
$I_{\text{R}}$	Reverse Leakage Current @ $V_{\text{RWM}}$
$V_{\text{BR}}$	Reverse Breakdown Voltage @ $I_{\text{T}}$
$I_{\text{T}}$	Test Current for Reverse Breakdown
$V_{\text{C}}$	Clamping Voltage @ $I_{\text{PP}}$
$I_{\text{PP}}$	Maximum Peak Pulse Current
$C_{\text{ESD}}$	Parasitic Capacitance
$V_{\text{R}}$	Reverse Voltage
f	Small Signal Frequency

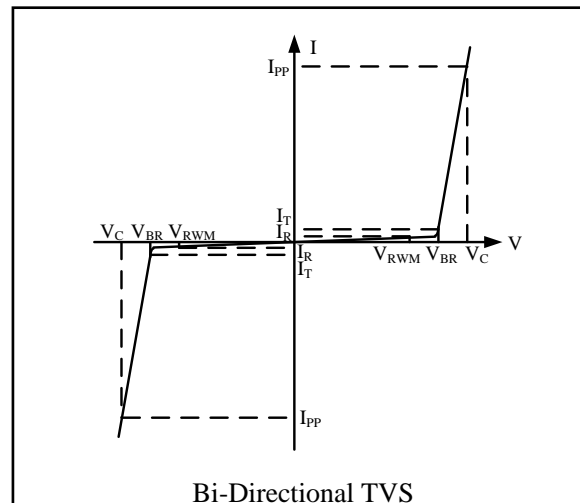

Parameter	Symbol	Min	Typ	Max	Unit	Test Condition
Reverse Working Voltage	$V_{\text{RWM}}$			3.3	V	
Breakdown Voltage	$V_{\text{BR}}$	5			V	$I_{\text{T}} = 1\text{mA}$
Reverse Leakage Current	$I_{\text{R}}$			0.3	$\mu\text{A}$	$V_{\text{RWM}} = 3.3\text{V}$
Clamping Voltage	$V_{\text{C}}$			10	V	$I_{\text{PP}} = 1\text{A}$ (8 x 20 $\mu\text{s}$ pulse)
Clamping Voltage	$V_{\text{C}}$			23	V	$I_{\text{PP}} = 4\text{A}$ (8 x 20 $\mu\text{s}$ pulse)
Junction Capacitance	$C_{\text{J}}$		0.35		pF	$V_{\text{R}} = 0\text{V}$ , $f = 1\text{MHz}$

**PROTECTION PRODUCTS**  
 Typical characteristics

**Fig1. 8/20 $\mu$ s Pulse Waveform**

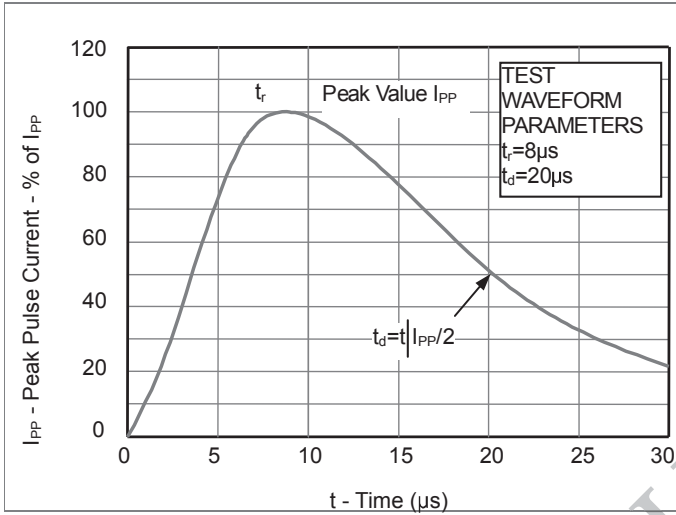

**Fig2. ESD Pulse Waveform (according to IEC 61000-4-2)**

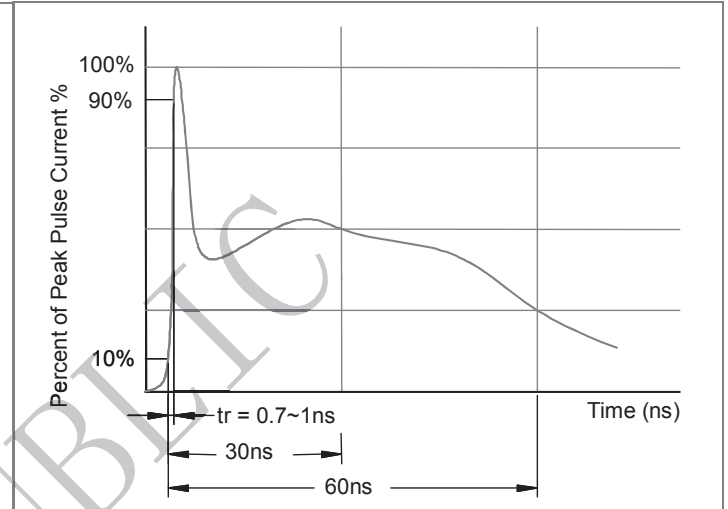

**Fig3. Power Derating Curve**

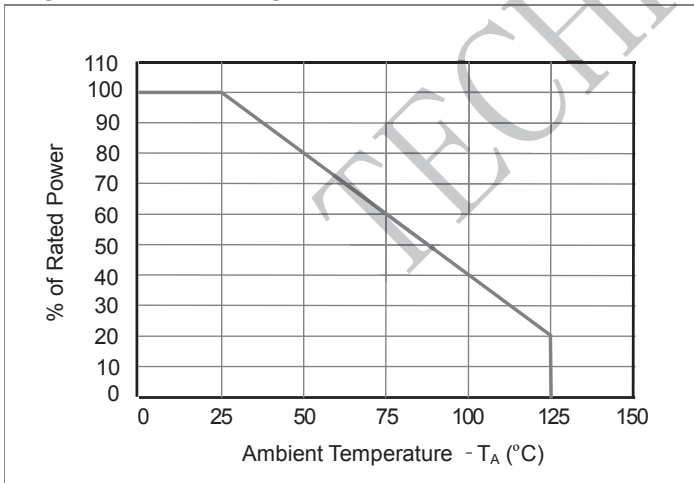

## Outline Drawing - DFN1006-2

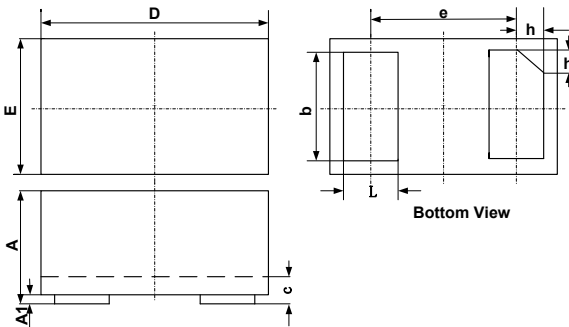

SYM	DIMENSIONS					
	MILLIMETERS			INCHES		
	MIN	NOM	MAX	MIN	NOM	MAX
A	0.45	0.50	0.55	0.018	0.020	0.022
A1	0.00	0.02	0.05	0.000	0.001	0.002
b	0.45	0.50	0.55	0.018	0.020	0.022
c	0.12	0.15	0.18	0.005	0.006	0.007
D	0.95	1.00	1.05	0.037	0.039	0.041
e	0.65 BSC			0.026 BSC		
E	0.55	0.60	0.65	0.022	0.024	0.026
L	0.20	0.25	0.30	0.008	0.010	0.012
h	0.07	0.12	0.17	0.003	0.005	0.007

## Land Pattern - DFN1006-2

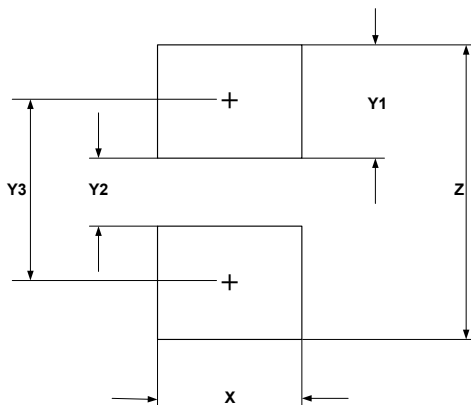

SYM	DIMENSIONS	
	MILLIMETERS	INCHES
X	0.60	0.024
Y1	0.50	0.020
Y2	0.30	0.012
Y3	0.80	0.032
Z	1.30	0.052