

REV	LOCATIONS	DESCRIPTION	DATE	REVISOR	APPD

**SPECIFICATIONS**

**Electrical**

Current Rating: 1A Max AC(rms)/DC  
Voltage Rating: 30V AC(rms)/DC  
Contact Resistance: 50 mΩ Max  
Withstanding Voltage: 300V AC r.m.s  
Insulation Resistance: 100 MΩ Min  
Temperature Range—Operating: -40°C~+85°C

**Mechanical**

Insertion force: 3.0kgf Max  
Withdrawal force: 0.7kgf Min  
Retention force: 0.5kgf Min

**Material And Plating**

Housing: LCP (UL94V-0), Black  
Contact: Copper alloy/ Gold in contact area, tin on tail.  
Shell: Copper alloy/ Nickel plated

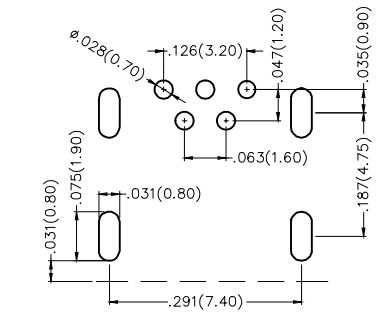
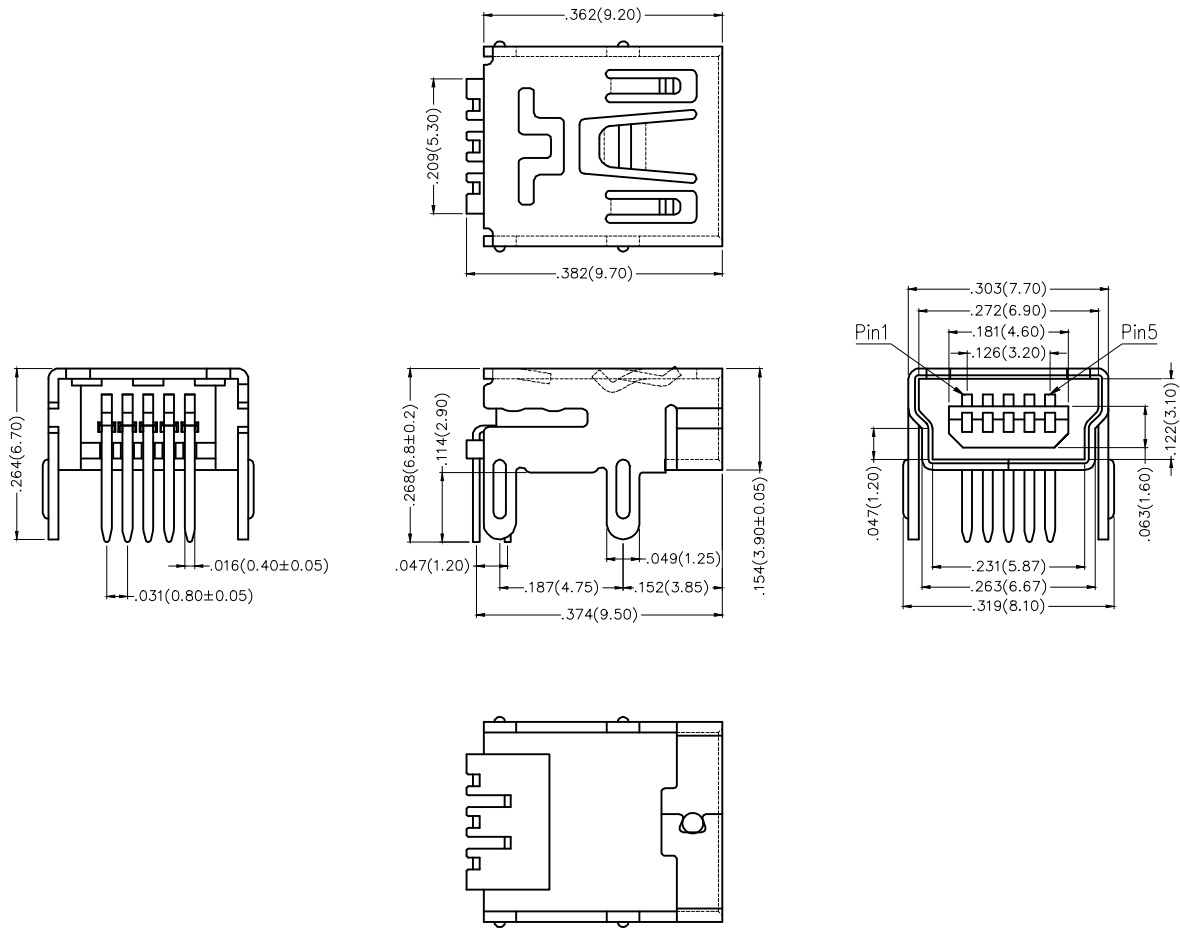

Recommended P.C.Board Layout  
General Tolerances: ±0.05mm

 THIRD ANGLE PROJECTION	GENERAL TOLERANCES (UNLESS SPECIFIED)		APPROVE BY FRANK	DATE 13/MAR/17	PART NO. FUS130-FDBK6K	ITEM NO. FUS130	 Leader Of Industry
	DESIGN UNITS Inch (metric)	X.±.012(0.30) X'.±5'	CHECKED BY CHERRY	DATE 13/MAR/17	TITLE Mini USB 5Circuits 90°Angle Female(DIP)		
SCALE 5:1	SIZE A4	X.XX±.008(0.20) X'±2'	DRAWN BY KATE	DATE 13/MAR/17	THIS DRAWING CONTAINS INFORMATION THAT IS PROPRIETARY TO TXGA INDUSTRIAL ELECTRONICS(S.Z)CO.,LTD AND SHOULD NOT BE USED WITHOUT WRITTEN PERMISSION		
		X.XX±.006(0.15) .XX'±1"					
		X.XXX±.004(0.10) .XXX'±0.5'					