

MAPX	MODIFICATION	DATE

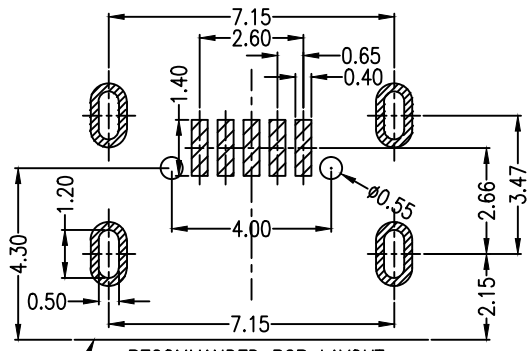
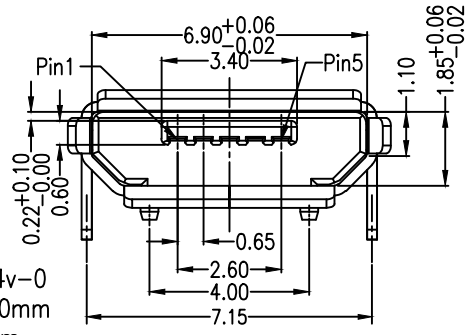
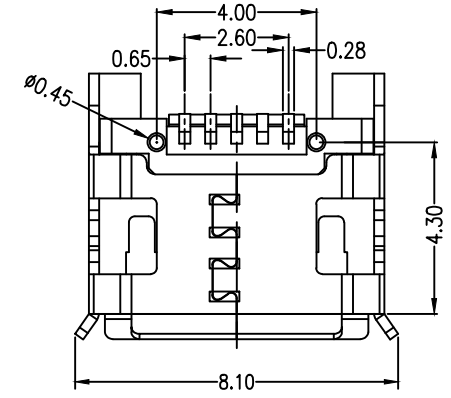
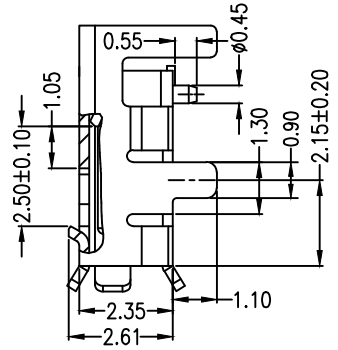
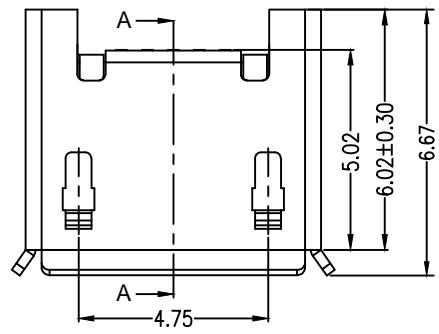
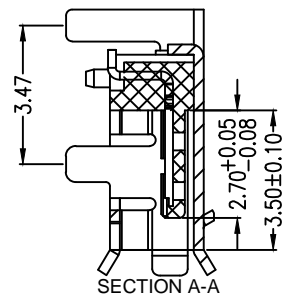
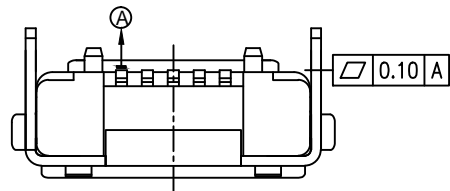

PCB EDGE
RECOMMENDED PCB LAYOUT
PCB图仅供参考

- Note:
- Material:
 - Housing: High temperature thermoplastic with g.f,UL94v-0
 - Contact: copper alloy,t=0.20mm
 - Shell: copper alloy,t=0.25mm
 - Specification:
 - Current rating:1,5PIN 1.8A Max/2,3,4PIN 1A Max.
 - Dielectric withstanding voltage: 100 V(ac) for 1 min.
 - Contact resistance: 30 mΩ Max.
 - Insulation resistance: 100 MΩ Min.
 - Total mating force: 3.57 Kgf Max.
 - Total unmating force: 1.0 Kgf Min.
 - Temperature range: -30°C~80°C

产品图 PRODUCT CHART DWG		深圳市精拓金电子有限公司					
公差一览表 TOLERANCE UNLESS OTHERWISE		单位 UNITS	MM	制图 DRAWING	Gavin	制图料号 PRODUCT PART NO.	920-A52A2021S10109
X.	±0.35	X.	±5.°	比例 SCALE	1:1	审核 CHKD	郭治富
.XX	±0.20	.XX	±1.°	日期 DATE	2012-05-12	核准 APPD	黄国荣
.XXX	±0.10	.XXX	±0.5°	角法 VIEW		版本 VER	A0
						产品名称 PRODUCT NO.	
						MICRO/SS-B 四脚DIP7.2有边脚长1.1有柱短端SMT	