

RoHS

MAPX

MODIFICATION

DATE

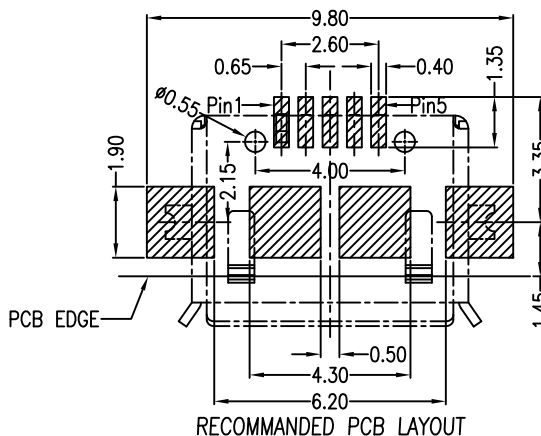
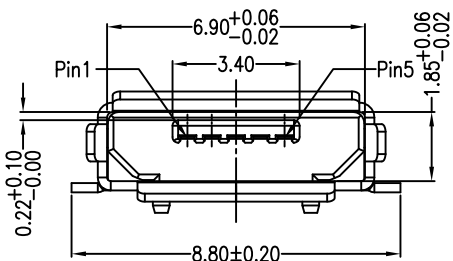
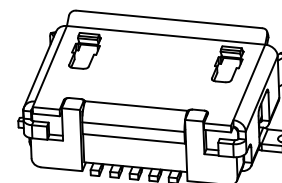
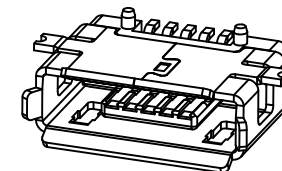
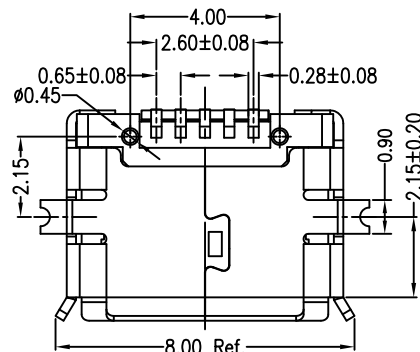
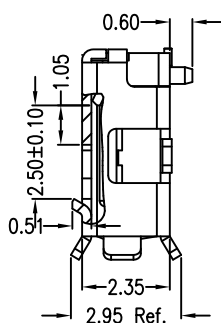
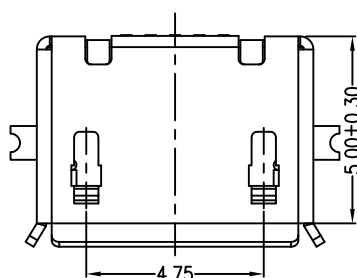
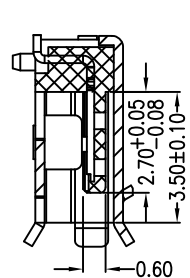
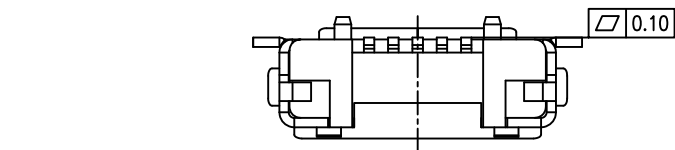

PCB图仅供参考

Note:

1.Material:

- 1.1 Housing: High temperature thermoplastic with g.f,UL94v-0
- 1.2 Contact: copper alloy,t=0.20mm
- 1.3 Shell: copper alloy,t=0.25mm

2.Specification:

- 2.1 Current rating:1,5PIN 1.8A Max/2,3,4PIN 1A Max.
- 2.2 Dielectric withstanding voltage: 100 V(ac) for 1 min.
- 2.3 Contact resistance: 30 mΩ Max.
- 2.4 Insulation resistance: 100 MΩ Min.
- 2.5 Total mating force: 3.57 Kgf Max.
- 2.6 Total unmating force: 1.0 Kgf Min
- 2.7 Temperature range: -30°C~80°C

产品图

PRODUCT CHART DWG

公差一览表

TOLERANCE UNLESS OTHERWISE

X.	±0.30	X.	±5.°
.X	±0.25	.X	±2.°
.XX	±0.15	.XX	±1.°
.XXX	±0.10	.XXX	±0.5°

深圳市精拓金电子有限公司

单位 UNITS	MM	制图 DRAWING	尹先华	制图料号 PRODUCT PART NO.	920-D52A2021S10100
比例 SCALE	1:1	审核 CHKD	郭治富	产品名称 PRODUCT NO.	MICRO 5S AB型两脚贴片8.8有柱有边有后盖LCP黑胶短端子雾锡
日期 DATE	2021-04-15	核准 APPD	黄国荣	角法 VIEW	版本 VER
					A0