

MAPX	MODIFICATION	DATE

A
B
C
D
E
F
G

A
B
C
D
E
F
G

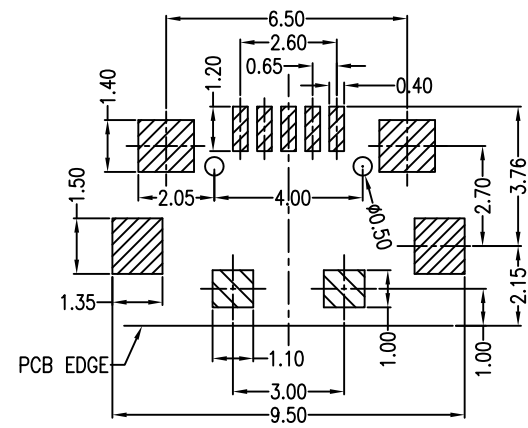
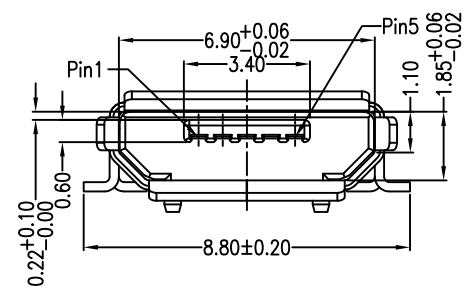
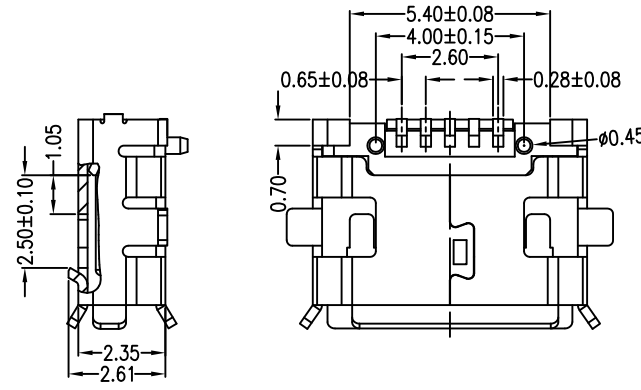
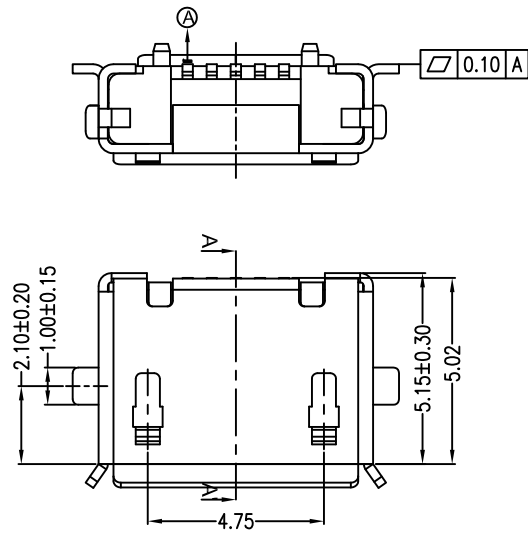
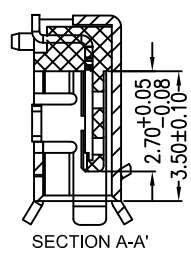

- Note:
- Material:
 - Housing: High temperature thermoplastic with g.f,UL94v-0
 - Contact: copper alloy,t=0.20mm
 - Shell: copper alloy,t=0.25mm
 - Specification:
 - Current rating:1,5PIN 1.8A Max/2,3,4PIN 1A Max
 - Dielectric withstanding voltage: 100 V(ac) for 1 min.
 - Contact resistance: 30 mΩ Max.
 - Insulation resistance: 100 MΩ Min.
 - Total mating force: 3.57 Kgf Max.
 - Total unmating force: 1.0 Kgf Min
 - Temperature range: -30°C~80°C

RECOMMENDED PCB LAYOUT PCB图仅供参考

产品图 PRODUCT CHART DWG		深圳市精拓金电子有限公司							
公差一览表 TOLERANCE UNLESS OTHERWISE		单位 UNITS	MM	制图 DRAWING	尹先华	制图料号 PRODUCT PART NO.	920-D52A2021S10109		
X.	±0.30	X.	±5.°	比例 SCALE	1:1	审核 CHKD	郭治富	产品名称 PRODUCT NAME	MICRO 5S B型四脚全贴有边有柱外焊脚
.X	±0.25	.X	±2.°	日期 DATE	2021-04-16	核准 APPD	黄国荣	角法 VIEW	长8.7LCP黑胶短端
.XX	±0.15	.XX	±1.°					版本 VER	AD
.XXX	±0.10	.XXX	±0.5°						

1 2 3 4 5 6 7 8 9 10