

SYM	ECN No.	MODIFICATION	DATE	ISSUED

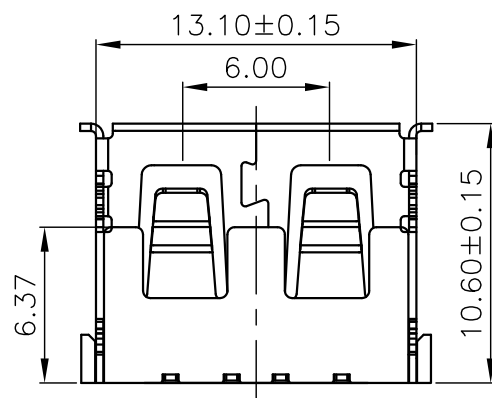
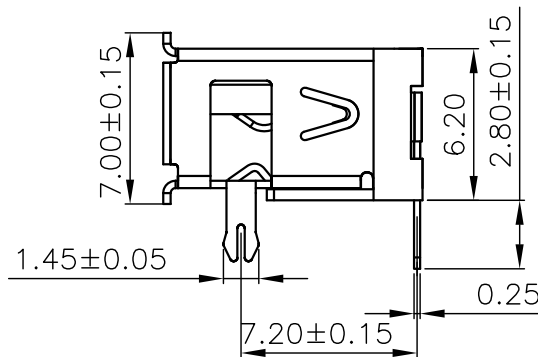
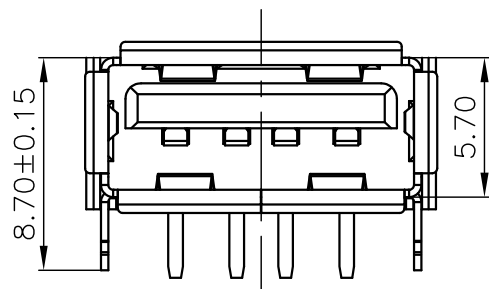
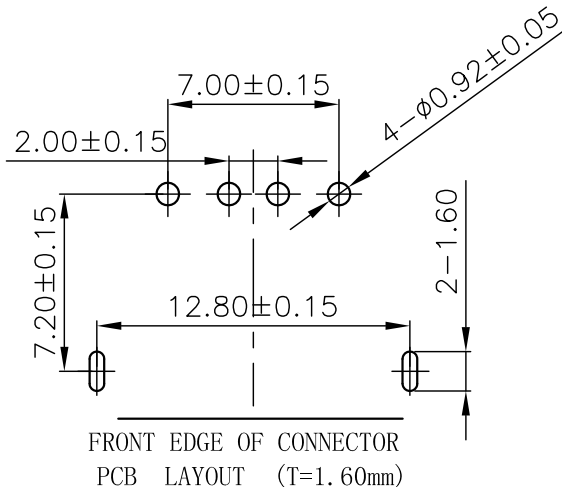
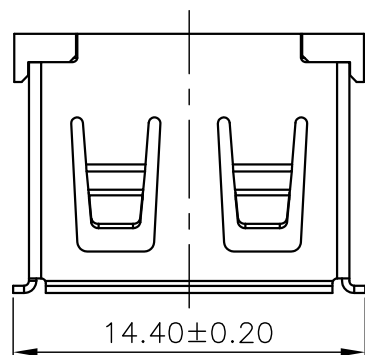

1	912-111A1011D10100	5	
2		6	
3		7	
4		8	

Note:

1.Material:

- 1.1,Housing: High temperature thermoplastic with/black G/F,UL94v-0
- 1.2,Contact: copper alloy,t=0.25mm
- 1.3,Shell: copper/Ferroalloy alloy,t=0.30mm

2.Specification:

- 2.1,Current rating:1.5A Max.
- 2.2,Dielectric withstanding voltage: 100 V(ac) for 1 min.
- 2.3,Contact resistance: 30 mΩ Max.
- 2.4,Insulation resistance: 100 MΩ Min.
- 2.5,Total mating force: 3.57 Kgf Max.
- 2.6,Total unmating force: 1.0 Kgf Min.

3.Finish:

- 3.1,Contact: Plated Golt in Mating Area: Tin On Solder Talls
- Shell: Nickel Plating

4.Environmental:

- 4.1,Temperature range: -55°C~85°C

PART ON:

912-11XAXXX1D1XX

- 电镀规格: 02, 镀金1u" 04, 镀金3u" 07, 镀金15u" 08, 镀金30u"
- 端子材质: 1, 青铜 2, 磷铜
- 端子规格: D, 90度 Y, 180度 S, SMT贴板
- 塑胶形态: 1=6.2有耳朵 2=6.5有耳朵 3=6.8有耳朵 4=5.7有耳朵 5=6.0有耳朵 6=6.2无耳朵 7=6.5无耳朵 8=6.8无耳朵 9=6.0有耳朵短路 A=6.2无耳朵 2.3短路 B=6.5反向单柱 0.8 C=6.0无耳朵MJ
- 塑胶颜色: 01, 白色 02, 黑色 03, 本色
- 塑胶材质: 1, PBT 2, LCP 3, PA9T 4, PPA 5, PA6T
- 对插方向: A, 正向 B, 反向
- 外壳材质: 1, 铁壳 2, 铜壳
- 插口类型: 1=有边方弹 2=无边方弹 3=有边尖弹 4=无边尖弹 5=无边大小弹
- 外壳脚型: 1, 前两脚 2, 后两脚 3, 四脚 4, 无脚
- 类别: D款10.0系列

DRAWN		深圳市精拓金电子有限公司		PART NO.			
CHECKED				912-111A1011D10100			
APPROVED		TITLE		DRAWING NO.			
		AF10. 6D款前两脚有边方弹 铁壳PBT白胶6. 2DIP		R912111A1011D102			
	UNIT	TOLERANCE		SCALE	SHEET	SIZE	REV.
	mm	.XXX±.10, .XX±.20, .X±.25, ANG±5°		1:1	1 OF 1	A4	X1