

650V GaN Power Transistor (FET)

Features

- Easy to use, compatible with standard gate drivers
- Low Q_{rr} , no free-wheeling diode required
- Excellent $Q_g \times R_{DS(on)}$ product (FOM)
- Low switching loss
- RoHS compliant and Halogen-free

Product Summary		
V_{DSS}	650	V
$R_{DS(on), typ}$	125	m Ω
$Q_{G, typ}$	22	nC
$Q_{RR, typ}$	55	nC

Applications

- Power adapters
- Telecom and datacom
- Automotive
- Servo motors

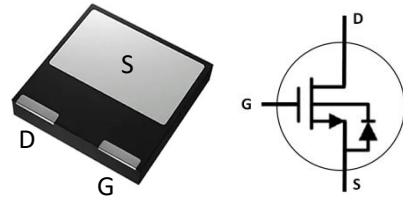

Packaging

Part Number	Package	Packaging	Base QTY
XG65T125HS1A	DFN 8*8mm	Tape and Reel	2500

Maximum ratings, at $T_c=25^\circ\text{C}$, unless otherwise specified

Symbol	Parameter		Limit Value	Unit
I_D	Continuous drain current @ $T_c=25^\circ\text{C}$		18	A
	Continuous drain current @ $T_c=100^\circ\text{C}$		11.5	A
I_{DM}	Pulsed drain current @ $T_c=25^\circ\text{C}$ (pulse width: 10us)		100	A
	Pulsed drain current @ $T_c=150^\circ\text{C}$ (pulse width: 10us)		70	A
V_{DSS}	Drain to source voltage ($T_j = -55^\circ\text{C}$ to 150°C)		650	V
V_{GS}	Gate to source voltage		± 20	V
P_D	Maximum power dissipation @ $T_c=25^\circ\text{C}$		67.5	W
T_c	Operating temperature	Case	-55 to 150	$^\circ\text{C}$
T_j		Junction	-55 to 150	$^\circ\text{C}$
T_s	Storage temperature		-55 to 150	$^\circ\text{C}$
T_{CSOLD}	Soldering peak temperature		260	$^\circ\text{C}$

Thermal Resistance

Symbol	Parameter	Typical	Unit
$R_{\theta JC}$	Junction-to-case	1.85	$^\circ\text{C}/\text{W}$
$R_{\theta JA}$	Junction-to-ambient	80	$^\circ\text{C}/\text{W}$

Electrical Parameters, at $T_J=25\text{ }^\circ\text{C}$, unless otherwise specified

Symbol	Min	Typ	Max	Unit	Test Conditions
Forward Device Characteristics					
$V_{DSS-MAX}$	650	-	-	V	$V_{GS}=0V$
BV_{DSS}	-	1700	-	V	$V_{GS}=0V, I_{DSS}=250\mu A$
$V_{GS(th)}$	-	1.62	-	V	$V_{DS}=V_{GS}, I_D=500\mu A$
$R_{DS(on)}^a$	-	125	150	m Ω	$V_{GS}=8V, I_D=4A, T_J=25^\circ C$
	-	250	-		$V_{GS}=8V, I_D=4A, T_J=150^\circ C$
I_{DSS}	-	7	15	μA	$V_{DS}=700V, V_{GS}=0V, T_J=25^\circ C$
	-	20	-	μA	$V_{DS}=700V, V_{GS}=0V, T_J=150^\circ C$
I_{GSS}	-	-	150	nA	$V_{GS}=20V$
	-	-	-150	nA	$V_{GS}=-20V$
C_{ISS}	-	1470	-	pF	$V_{GS}=0V, V_{DS}=650V, f=1MHz$
C_{OSS}	-	55	-	pF	
C_{RSS}	-	1.5	-	pF	
$C_{O(er)}$	-	70	-	pF	$V_{GS}=0V, V_{DS}=0\text{ to }650V$
$C_{O(tr)}$	-	120	-	pF	
Q_G	-	22	-	nC	$V_{DS}=400V, V_{GS}=0V\text{ to }8V, I_D=10A$
Q_{GS}	-	4.2	-		
Q_{GD}	-	3.6	-		
$t_{D(on)}$	-	30	-	nS	$V_{DS}=400V, V_{GS}=0V\text{ to }12V, I_D=10A, R_G=34\Omega$
t_R	-	10	-		
$t_{D(off)}$	-	60	-		
t_F	-	9	-		
Reverse Device Characteristics					
V_{SD}	-	1.3	-	V	$V_{GS}=0V, I_S=5A, T_J=25^\circ C$
	-	1.9	-		$V_{GS}=0V, I_S=10A, T_J=25^\circ C$
	-	3	-		$V_{GS}=0V, I_S=10A, T_J=150^\circ C$
t_{RR}	-	14	-	ns	$I_S=10A, V_{GS}=0V, di/dt=1000A/\mu s, V_{DD}=400V$
Q_{RR}	-	55	-	nC	

Notes:

- a. Dynamic on-resistance; see Fig. 15 and 16 for test circuit and conditions

Circuit Implementation

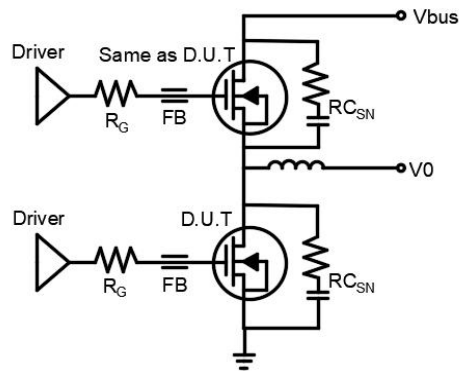

Recommended Drive Circuit

Recommended gate drive: (0 V, 12 V) with $R_{G(\text{tot})} = 34 \Omega$, where $R_{G(\text{tot})} = R_G + R_{\text{Driver}}$

Gate Ferrite Bead (FB)	Gate Resistance1 (R_G)	RC Snubber (R_{CSN})
MMZ1608S301ATA00	33 Ω	47 pF + 15 Ω

Notes:

- RCsn should be placed as close as possible to the drain pin
- The layout and wiring of the drive circuit should be as short as possible

Typical Characteristics, at $T_c=25^\circ\text{C}$, unless otherwise specified

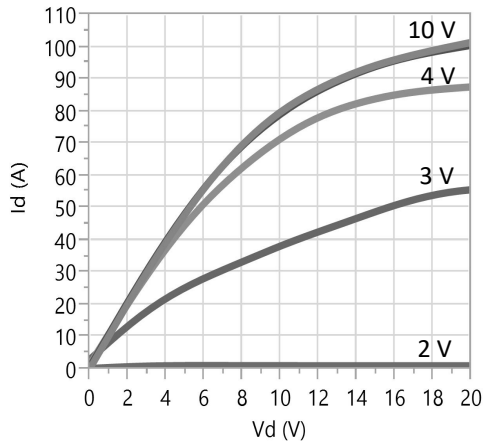

Figure 1. Typical Output Characteristics $T_j=25^\circ\text{C}$

Parameter: V_{GS}

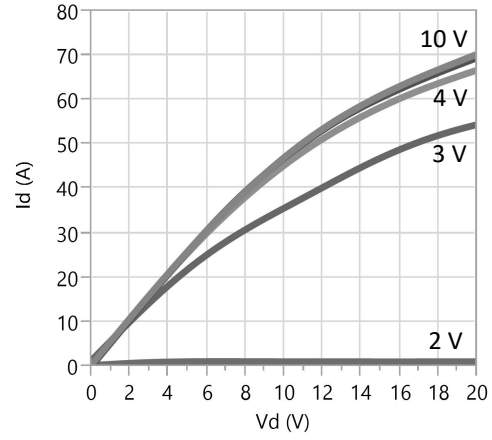

Figure 2. Typical Output Characteristics $T_j=150^\circ\text{C}$

Parameter: V_{GS}

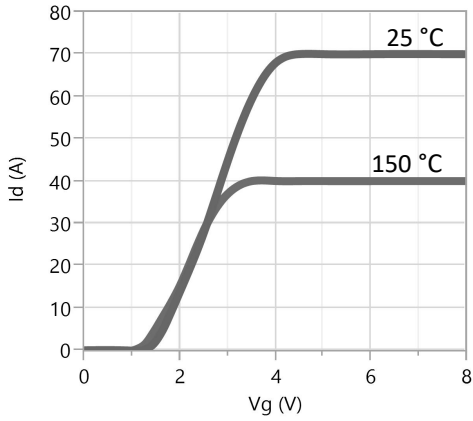

Figure 3. Typical Transfer Characteristics

$V_{DS}=10\text{V}$, Parameter: T_j

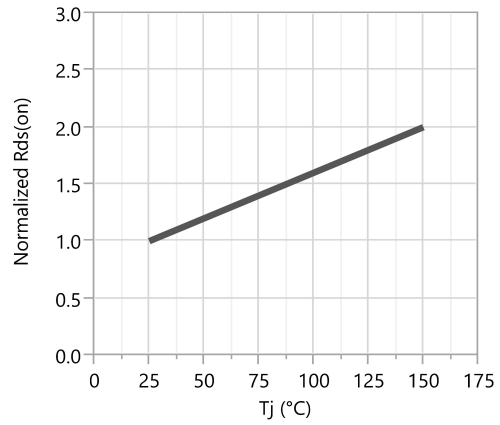

Figure 4. Normalized On-resistance

$I_D=4\text{A}$, $V_{GS}=8\text{V}$

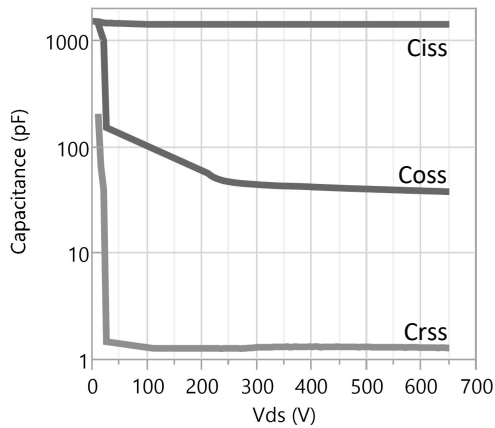

Figure 5. Typical Capacitance

$V_{GS}=0\text{V}$, $f=1\text{MHz}$

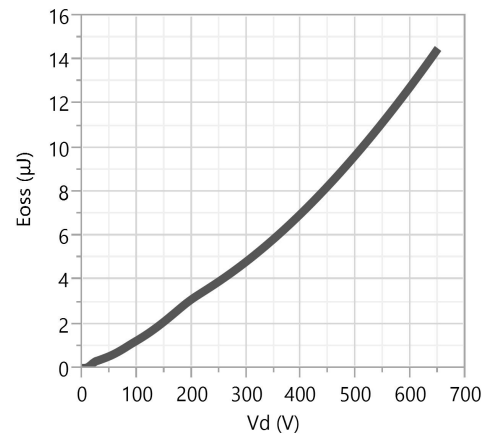

Figure 6. Typical C_{OSS} Stored Energy

Typical Characteristics, at $T_c=25\text{ }^\circ\text{C}$, unless otherwise specified

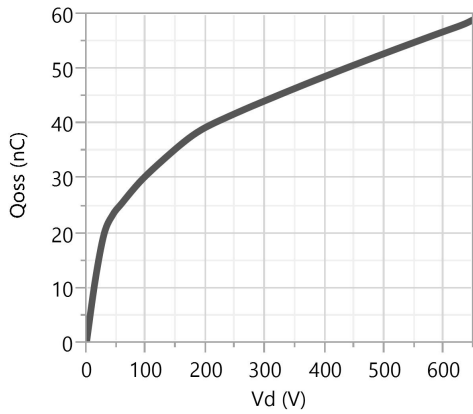

Figure 7. Typical Qoss

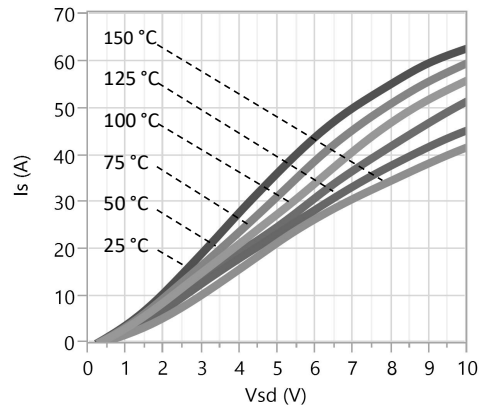

Figure 8. Forward Characteristic of Rev. Diode

$$I_s = f(V_s), \text{ Parameter } T_j$$

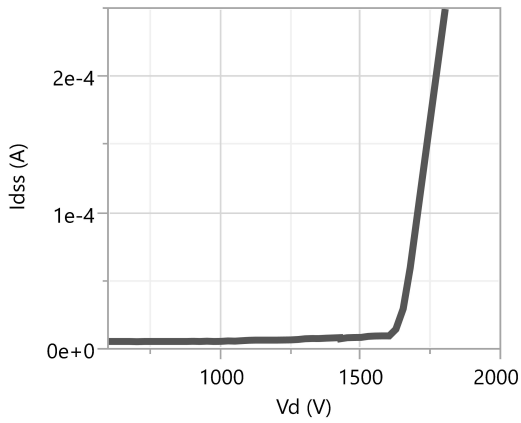

Figure 9. Drain-Source Breakdown Voltage

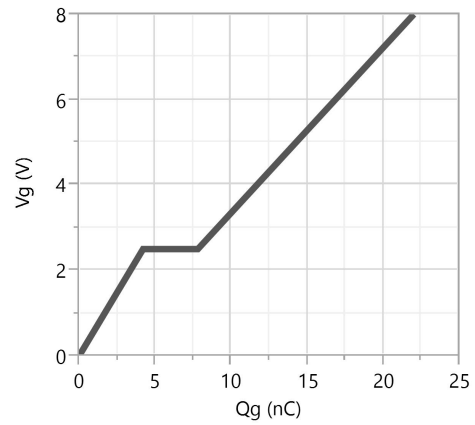

Figure 10. Typical Gate Charge

$$I_{DS}=10A, V_{DS}=400V$$

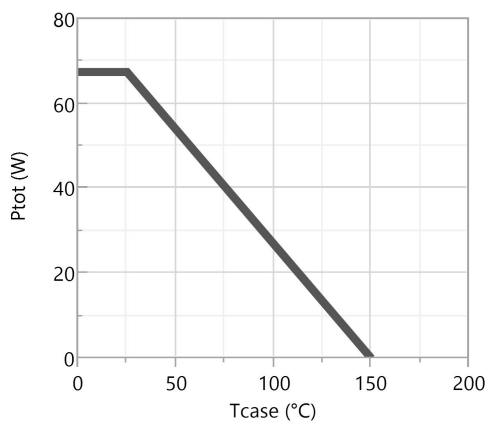

Figure 11. Power Dissipation

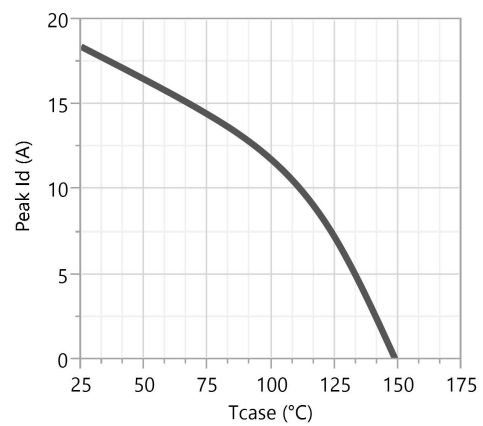

Figure 12. Current Derating

Test Circuits and Waveforms

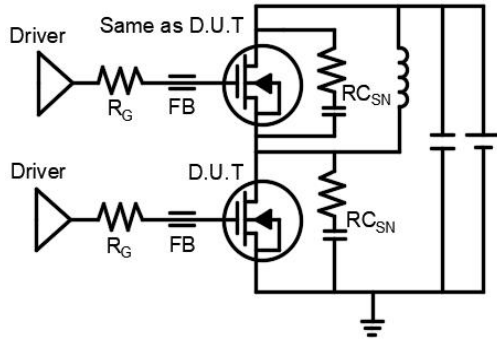

Figure 13. Switching Time Test Circuit

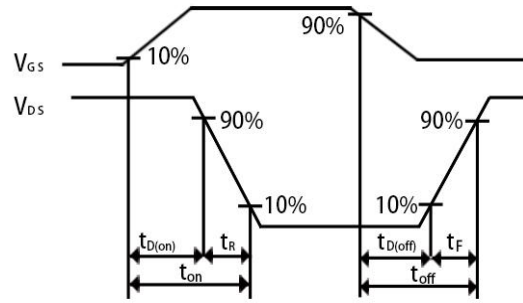

Figure 14. Switching Time Waveform

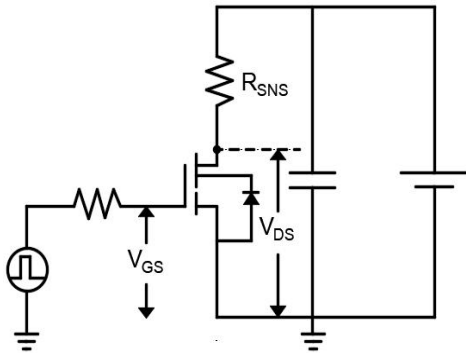

Figure 15. Dynamic $R_{DS(on)}$ Test Circuit

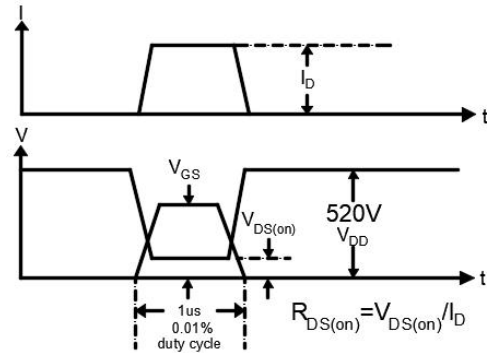

Figure 16. Dynamic $R_{DS(on)}$ Waveform

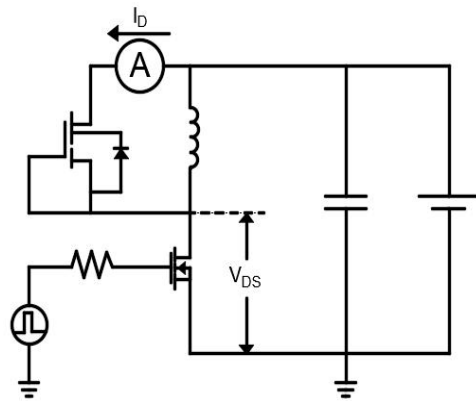

Figure 17. Diode Characteristic Test Circuit

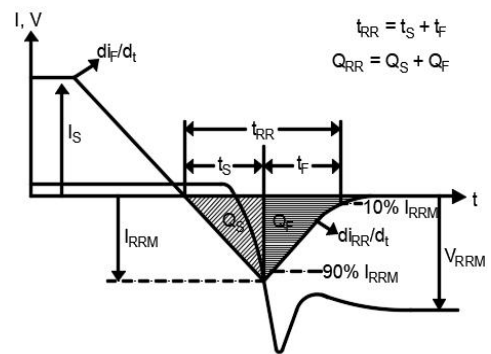

Figure 22. Diode Recovery Waveform

Design Considerations

Fast switching GaN device can reduce power conversion losses, and thus enable high frequency operations. Certain PCB design rules and instructions, however, need to be followed to take full advantages of fast switching GaN devices.

Before evaluating Xinguan's GaN devices, please refer to the table below which provides some practical rules that should be followed during the evaluation.

When Evaluating Xinguan's GaN Devices:

DO	DO NOT
Make sure the traces are as short as possible for both drive and power loops to minimize parasitic inductance	Using Xinguan's devices in GDS board layouts
Use the test tool with the shortest inductive loop, and make sure test points should be placed close enough	Use differential mode probe or probe ground clip with long wires
Minimize the lead length of TO packages when installing them to PCB	Use long traces in drive circuit, or long lead length of the devices

Mechanical

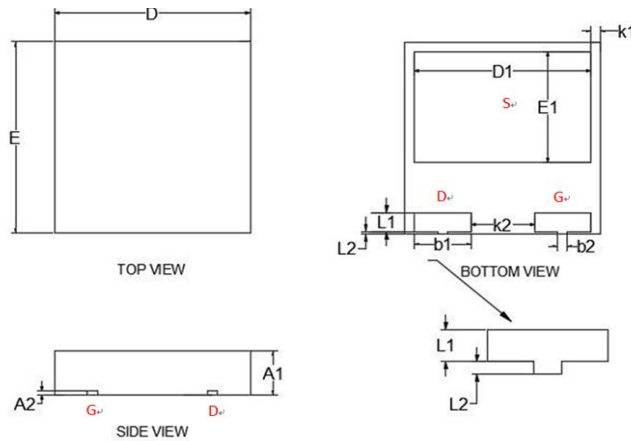

DFN 8*8 (HS) Package

Symbol	Dimensions in Millimeters		
	MIN	NOM	MAX
A1	1.825	1.850	1.875
A2	0.195	0.203	0.211
D	7.950	8.000	8.050
E	7.950	8.000	8.050
D1	7.150	7.200	7.250
E1	4.550	4.600	4.650
K1	0.375	0.400	0.425
K2	2.575	2.600	2.625
b1	2.275	2.300	2.325
b2	0.375	0.400	0.425
L1	0.775	0.800	0.825
L2	0.075	0.100	0.125

Package Outlines

Dimensions are show in millimeters

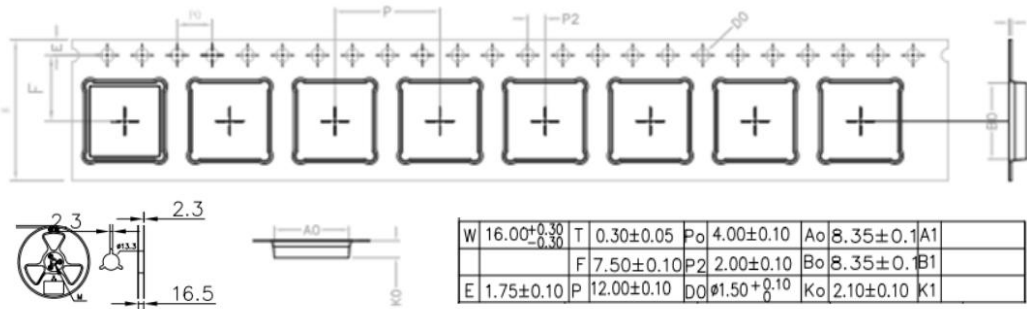

Revision History

Version	Date	Change(s)
1.0	5/1/2020	Release formal datasheet
1.1	6/1/2020	Added Package Outlines