

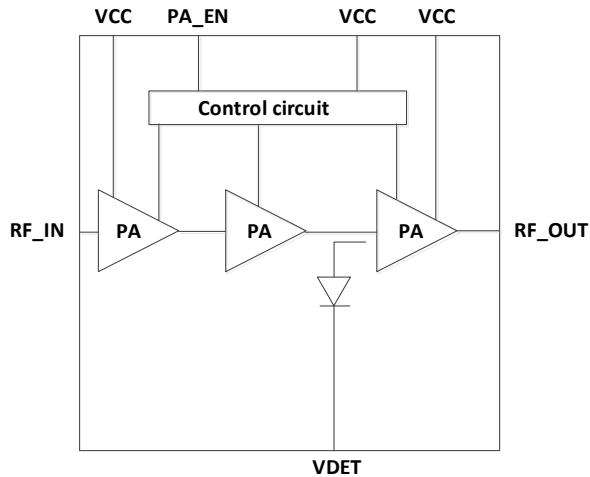

2.4GHz High Power WLAN Power Amplifier



Description

KCT6225H is a 2.4GHz Power Amplifier (PA) with superior output power, high efficiency and high linearity. The device incorporates a power detector for close loop monitoring of the output power, and a digital control for device on/off control.

KCT6225H is designed for use in the 2.4GHz Industrial, Scientific, Medical (ISM) band of Wireless Local Area Network (WLAN) applications.

KCT6225H is assembled in a compact, low-profile 3*3*0.75mm 16-pin QFN package. It is the ideal PA solution for implementing 2.4GHz high power WLAN systems supporting multiple standards including 802.11b/g/n/ac.

Applications

- ▶ 2.4GHz WLAN (IEEE 802.11b/g/n/ac)
- ▶ PCMCIA Cards
- ▶ Access Points
- ▶ PC Cards

FEATURES

- ▶ 2.4GHz High Power PA
- ▶ Output Power: +24.5dBm @ 1.8% EVM, VHT40/MCS9, 5V
- ▶ Output Power: +25.5dBm @ 3% EVM, HT20/MCS7, 5V
- ▶ Gain: 31.5 dB at 5V
- ▶ Fully-matched Input and Output
- ▶ Digital Power Amplifier enable Pin
- ▶ Very Low DC Power Consumption
- ▶ ESD Protection Circuitry on All Ports
- ▶ Small Package: QFN 16-pin 3×3×0.75mm, with Exposed Ground Pad (MSL3, 260 °C per JEDEC J-STD-020)
- ▶ ROHS and REACH Compliant

PIN ASSIGNMENTS

Pin Number	Pin Name	Description
1	RF_IN	RF Input; DC shorted to GND
2	PA_EN	PA Enable
3,5,6,9,12,16	GND	Ground - Must be connected to Ground in the Application Circuit
4,13,15	VDD	Supply Voltage
7	DET	Detector Output Voltage
8,14	NC	Internally Not Connected
10,11	RF_OUT	RF Output; DC shorted to GND

PIN-OUT DIAGRAM (Top View)

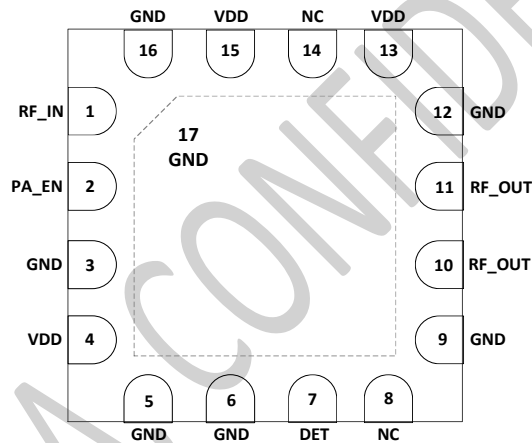

ABSOLUTE MAXIMUM RATINGS

Parameters	Units	Min	Max	Conditions
DC VDD Voltage Supply	V	0	6.0	All VDD Pins, RF_OUT
DC Control Pin Voltage	V	0	3.6	PA_EN
Maximum Input Power (50Ω load)	dBm		+12	
Storage Temperature	°C	-40	+150	
Junction Temperature	°C		+150	
Thermal Resistance (θ_{JC})	°C/W		+35	

NOTE: Sustained operation at or above the Absolute Maximum Ratings for any one or combinations of the above parameters may result in permanent damage to the device and is not recommended.

All Maximum RF Input Power Ratings assume 50-ohm terminal impedance.



NOMINAL OPERATING CONDITIONS

Parameters	Units	Min	Typical	Max	Conditions
Supply Voltage	V	4.75	5	5.25	All VDD Pins
Control Pin Voltage "High"	V	1.8		3.6	
Control Pin Voltage "Low"	V	0		0.4	
Supply Current	μA			10	V _{EN} =0 V, No RF
Operating Ambient Temperature	°C	-40	+25	+85	See note 2

NOTE 2: For operation above +85 °C, use the θ_{ja} as guidance for system design to assure the junction temperature will not exceed the maximum of +200 °C.

KCT6225H ELECTRICAL SPECIFICATIONS

(VDD= 5V, T = 25 °C, Unless Otherwise Noted)

Parameters	Units	Min	Typical	Max	Conditions
Frequency Range	GHz	2.4		2.5	All RF Pins Terminated by 50 Ohm
Small-Signal Gain	dB	30	31.5	33	
Output Power	dBm	23.5 24.5 27	24.5 25.5 28		VHT40/MCS9, 1.8%EVM, Preamble only HT20/MCS7, 3%EVM, Preamble only Mask Power
Output P1dB	dBm	29.5	31		No Modulation
Input Return Loss	dB	8	10		
Output Return Loss	dB	8	10		
Supply Current—Sum of all VDDs	mA	150 360 380 480	165 390 420 520	180 410 450 570	No RF P _{OUT} =+24.5dBm P _{OUT} =+25.5dBm P _{OUT} =+28dBm
Gain Variation Over Band	dB		1		
Harmonic 2 nd harmonics 3 rd harmonics	dBm/MHz		-25 -35	-20 -30	P _{out} =+28dBm, IEEE 802.11b, 1Mbps
Rise and Fall Time	μs		0.4	0.5	
Power Detector Output Voltage	V	0.07 0.12 0.30 0.55 0.58 0.65	0.12 0.17 0.35 0.60 0.63 0.7	0.17 0.22 0.40 0.65 0.68 0.75	@ No RF @+10dB @+16dBm @+24.5dBm @+25.5dBm @+28dBm



PRODUCT QUALIFICATION

Parameters	Units	Min	Max	Conditions
ESD – Human Body Mode	V		1500	HBM
ESD – Charge Device Mode	V		1000	CDM
ESD – Machine Mode	V		50	MM

ESD HANDLING: Although this device is designed to be as robust as possible, electrostatic discharge (ESD) can damage this device. This device must be protected at all times from ESD when handling or transporting. Static charges may easily produce potentials of several kilovolts on the human body or equipment, which can discharge without detection. Industry-standard ESD handling precautions should be used at all times.

CONTROL LOGIC TABLE

PA_EN	Mode of Operation
1	Transmit Mode
0	Shutdown

Note: "1" denotes high voltage state (> 1.8V)
"0" denotes low voltage state (<0.4V) at Control Pins
"X" denotes the don't care state
1KΩ – 10KΩ series resistor may be required for each control line

ORDERING INFORMATION

Product Description	Product Part Number	Package Type	Package Quantity
KCT6225H: 2.4GHz WLAN Power Amplifier	KCT6225H	13" tape and reel	5000pcs / reel



APPLICATION SCHEMATIC

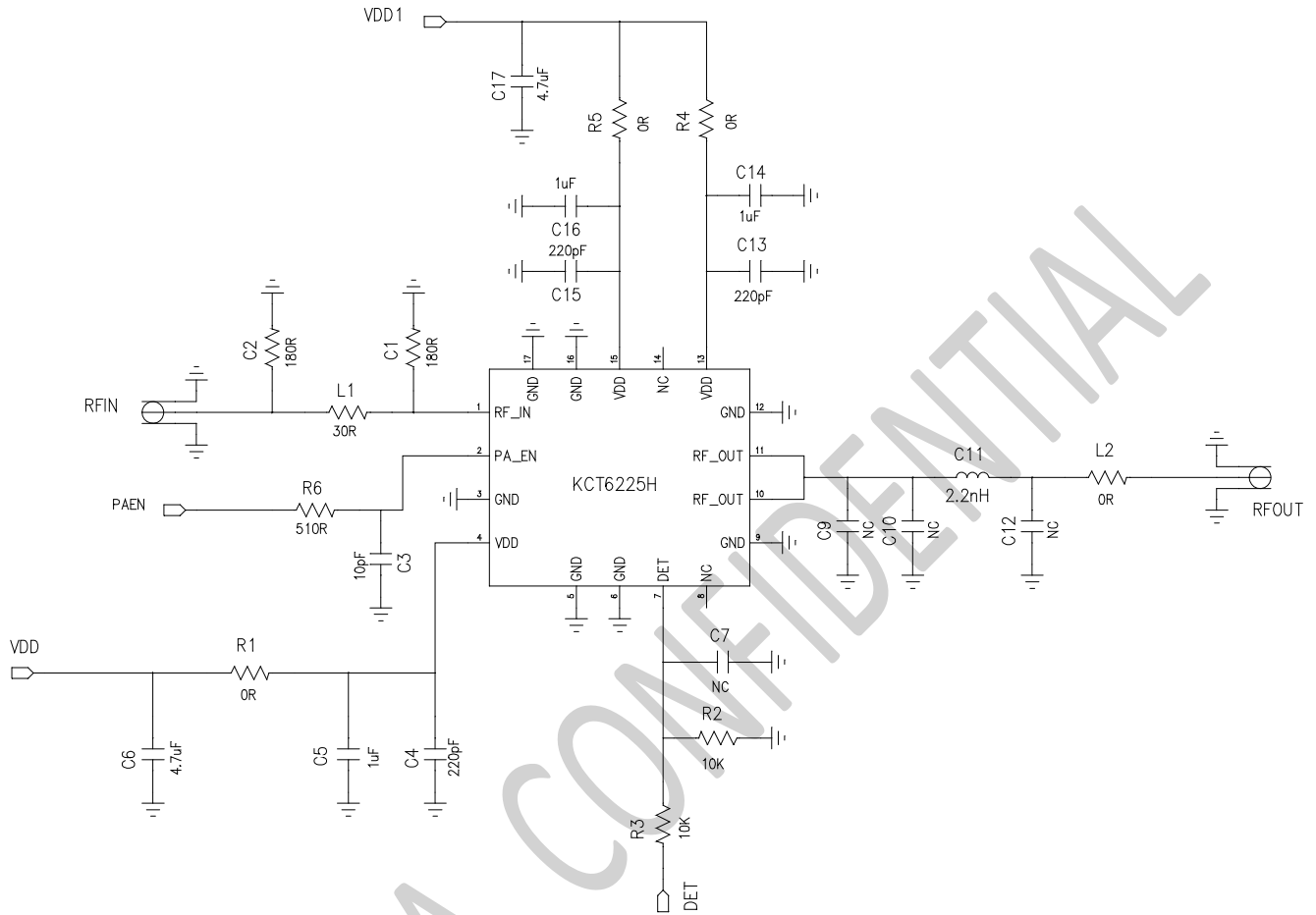



EVB PICTURE and EVB BOM

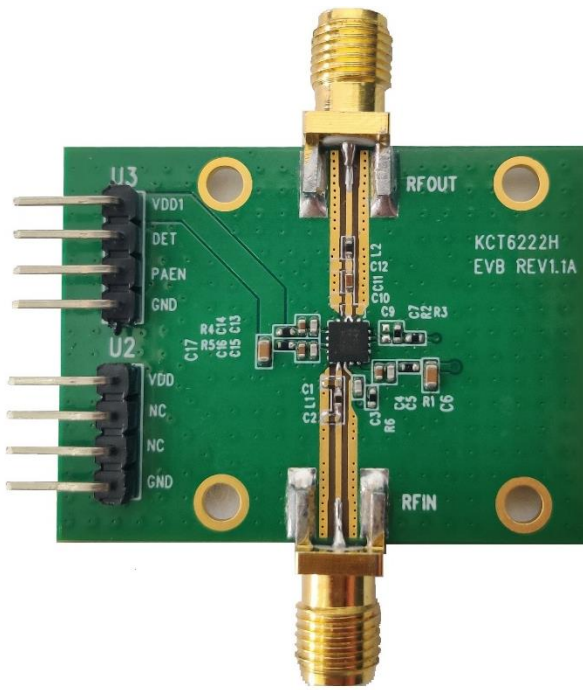

[EVB Assembly]

Reference	Value	Footprint	Notes
C4,C13,C15	220PF	0402	X5R/X7R
C3	10PF	0402	X5R/X7R
C5,C14,C16	1UF	0402	X5R/X7R
C6,C17	4.7UF	0603	X5R/X7R
R2,R3	10K	0402	Det. load
R6	510ohm	0402	ROHM
R1,L2,R4,R5	0ohm	0402	Series Pad
C11	2.2nH	0402	LQP15HS
L1	30ohm	0402	ROHM

[EVB BOM]



PCB LAYOUT FOOTPRINT (All dimensions in mm)

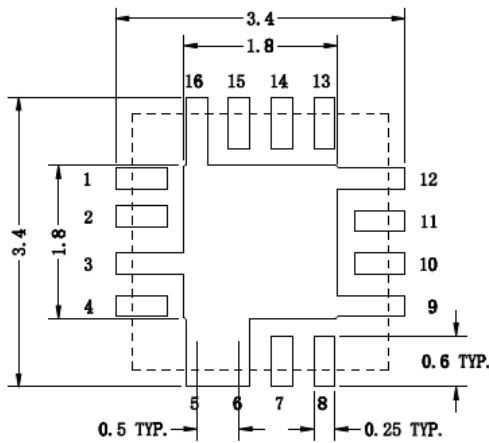

Board Metal

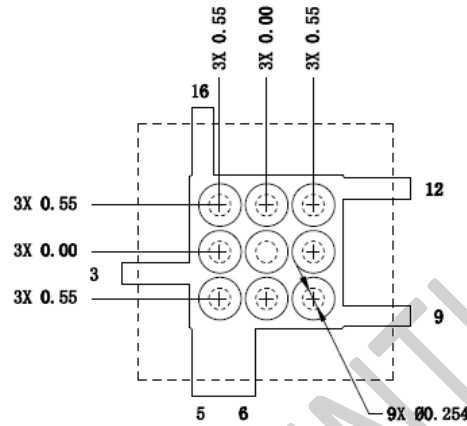

Via Pattern

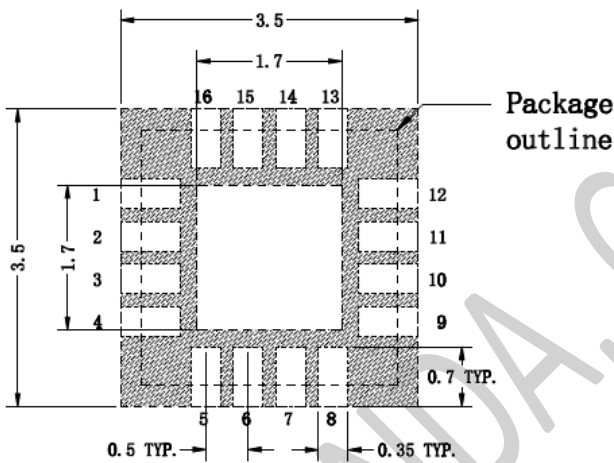

Solder Mask Pattern

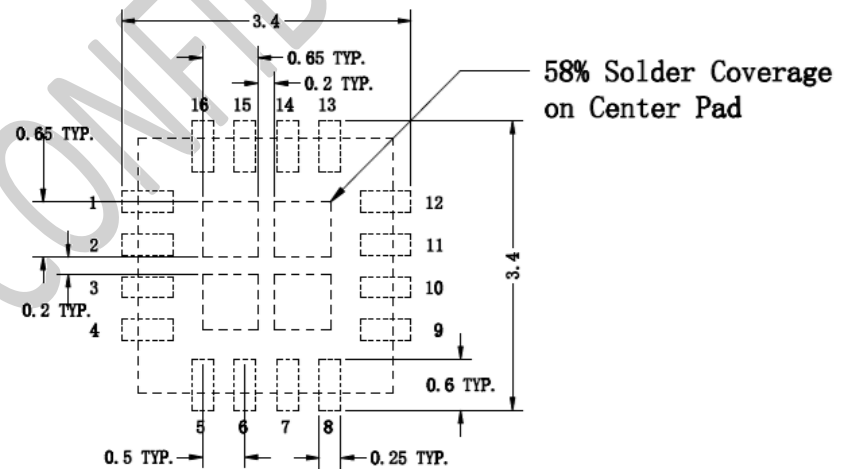

Stencil Pattern



PACKAGE DIMENSIONS (All Dimensions in mm):

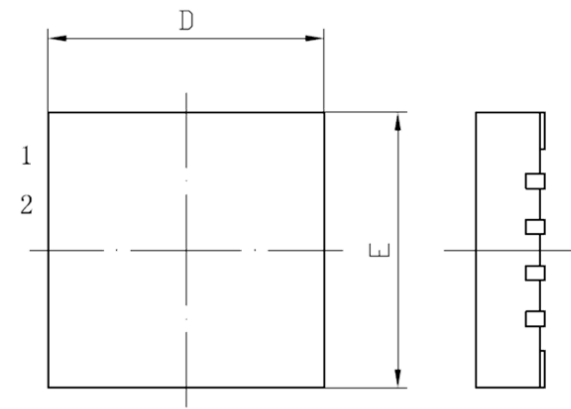

TOP VIEW

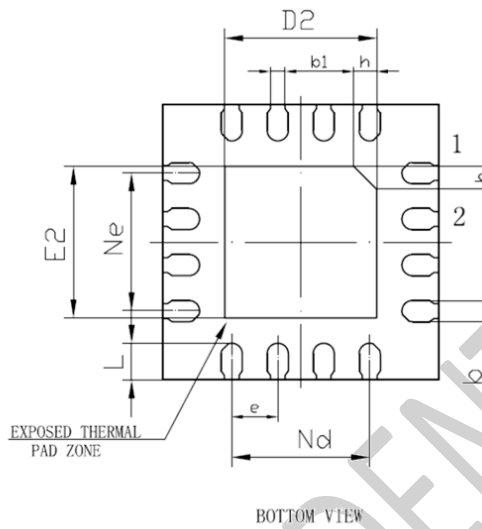

BOTTOM VIEW

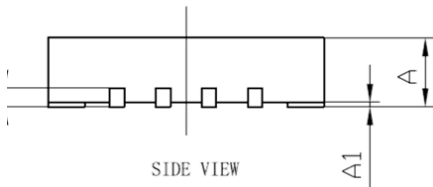

SIDE VIEW

SYMBOL	MILLIMETER		
	MIN	NOM	MAX
A	0.70	0.75	0.80
A1	0	0.02	0.05
b	0.18	0.25	0.30
b1	0.16REF		
c	0.18	0.20	0.25
D	2.90	3.00	3.10
D2	1.55	1.65	1.75
e	0.50BSC		
Ne	1.50BSC		
Nd	1.50BSC		
E	2.90	3.00	3.10
E2	1.55	1.65	1.75
L	0.35	0.40	0.45
h	0.20	0.25	0.30
L/F载体尺寸 (mm)	75x75		

KCT NDA, CONFIDENTIAL



PART MARKING

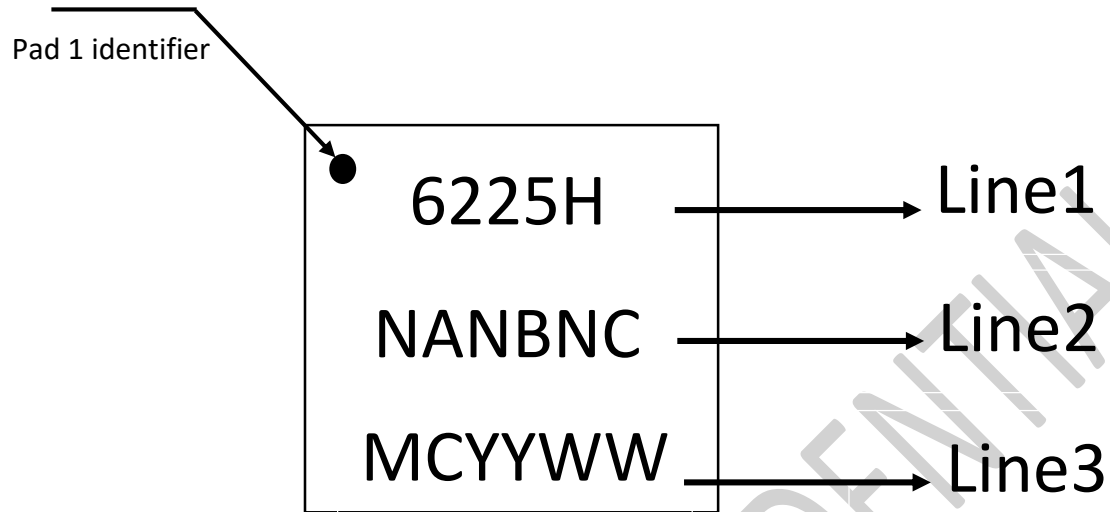

Line	Marking	Description
1	6225H	Product name
2	NABNCD	DIE lot 1: NAB; DIE lot 2: NCD; °
3	MCYYWW	MC: Manufacturer Code YYWW: YY year WW week