

Description

The 9ZX21901 is a version of the Intel DB1900Z Differential Buffer with an adjustable external feedback path allowing the user to eliminate trace delays from their design. It is suitable for PCIe Gen3 or QPI applications. The part is backwards compatible to PCIe Gen1 and Gen2. The device maintains low drift for critical QPI applications. In bypass mode, the IDT9ZX21901 can provide outputs up to 400MHz.

Recommended Application

19 output PCIe Gen3/QPI buffer with adjustable feedback for Romley platforms

Output Features

- 19 - 0.7V current mode differential HCSL output pairs

Features/Benefits

- External feedback path; Adjustable input-to-output delay
- 9 Selectable SMBus addresses/ Multiple devices can share same SMBus segment
- 8 dedicated OE# pins/ hardware control of outputs
- PLL or bypass mode/ PLL can dejitter incoming clock
- Selectable PLL BW/ minimizes jitter peaking in downstream PLL's
- Spread spectrum compatible/tracks spreading input clock for EMI reduction
- SMBus Interface/ unused outputs can be disabled
- 100MHz & 133.33MHz PLL mode/ Legacy QPI support
- Undriven differential outputs in Power Down mode for maximum power savings

Key Specifications

- Cycle-to-cycle jitter: < 50ps
- Output-to-output skew: <65ps
- Input-to-output delay: User adjustable
- Input-to-output delay variation: <50ps
- Phase jitter: PCIe Gen3 < 1ps rms
- Phase jitter: QPI 9.6GB/s < 0.2ps rms

Functional Block Diagram

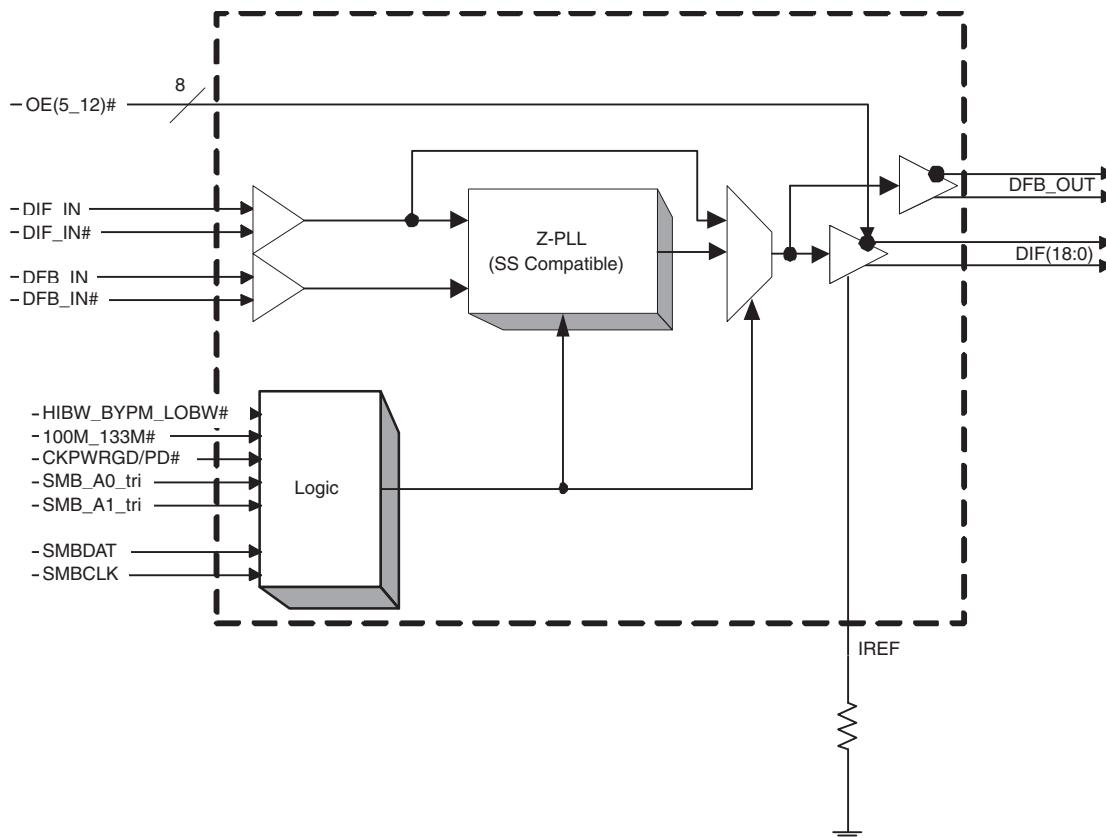

Pin Configuration

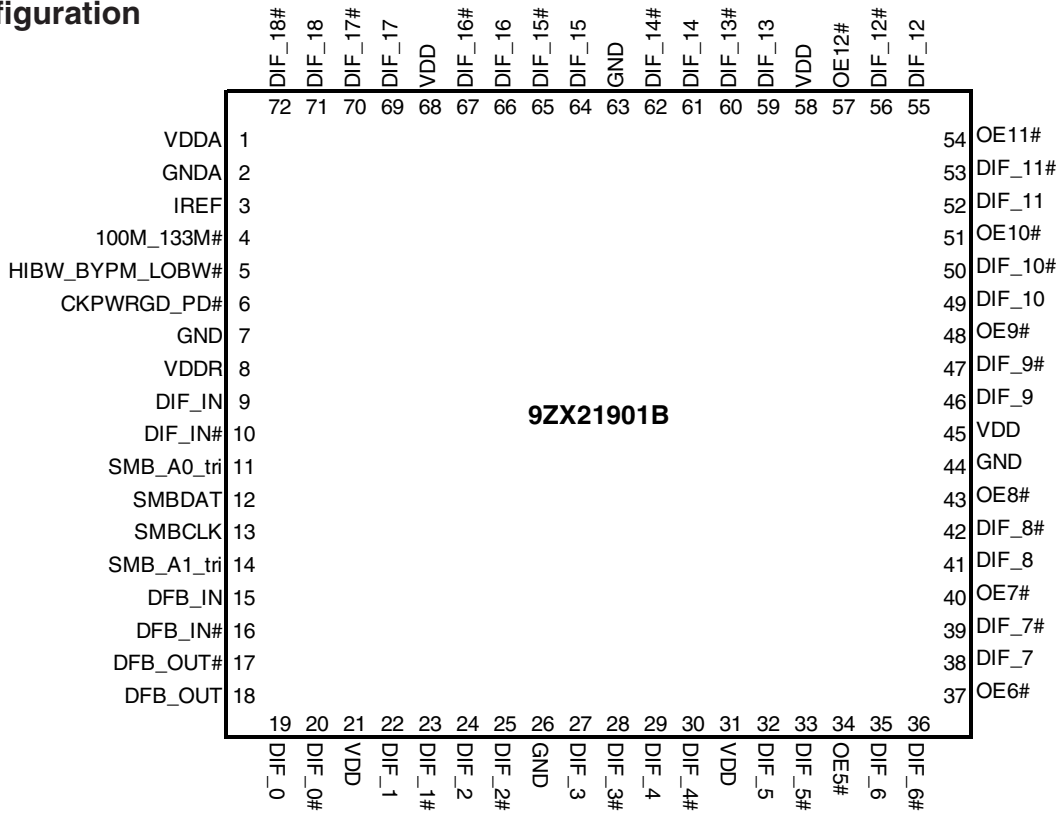

72-pin MLF

PLL Operating Mode Readback Table

HiBW_BypM_LoBW#	Byte0, bit 7	Byte 0, bit 6
Low (Low BW)	0	0
Mid (Bypass)	0	1
High (High BW)	1	1

Functionality at Power Up (PLL Mode)

100M_133M#	DIF_IN (MHz)	DIF (MHz)
1	100.00	DIF_IN
0	133.33	DIF_IN

PLL Operating Mode

HiBW_BypM_LoBW#	MODE
Low	PLL Lo BW
Mid	Bypass
High	PLL Hi BW

NOTE: PLL is OFF in Bypass Mode

Tri-level Input Thresholds

Level	Voltage
Low	<0.8V
Mid	1.2<Vin<1.8V
High	Vin > 2.2V

Power Connections

Pin Number		Description
VDD	GND	
1	2	Analog PLL
8	7	Analog Input
21, 31, 45, 58, 68	26, 44, 63	DIF clocks

9ZX21901 SMBus Addressing

Pin		SMBus Address (Rd/Wrt bit = 0)
SMB_A1_tri	SMB_A0_tri	
0	0	D8
0	M	DA
0	1	DE
M	0	C2
M	M	C4
M	1	C6
1	0	CA
1	M	CC
1	1	CE

Pin Description

PIN #	PIN NAME	PIN TYPE	DESCRIPTION
1	VDDA	PWR	3.3V power for the PLL core.
2	GNDA	PWR	Ground pin for the PLL core.
3	IREF	OUT	This pin establishes the reference for the differential current-mode output pairs. It requires a fixed precision resistor to ground. 475ohm is the standard value for 100ohm differential impedance. Other impedances require different values. See data sheet.
4	100M_133M#	IN	Input to select operating frequency 1 = 100MHz, 0 = 133.33MHz
5	HIBW_BYPM_LOBW#	IN	Trilevel input to select High BW, Bypass or Low BW mode. See PLL Operating Mode Table for Details.
6	CKPWRGD_PD#	IN	Notifies device to sample latched inputs and start up on first high assertion, or exit Power Down Mode on subsequent assertions. Low enters Power Down Mode.
7	GND	PWR	Ground pin.
8	VDDR	PWR	3.3V power for differential input clock (receiver). This VDD should be treated as an analog power rail and filtered appropriately.
9	DIF_IN	IN	0.7 V Differential TRUE input
10	DIF_IN#	IN	0.7 V Differential Complementary Input
11	SMB_A0_tri	IN	SMBus address bit. This is a tri-level input that works in conjunction with the SMB_A1 to decode 1 of 9 SMBus Addresses.
12	SMBDAT	I/O	Data pin of SMBUS circuitry, 5V tolerant
13	SMBCLK	IN	Clock pin of SMBUS circuitry, 5V tolerant
14	SMB_A1_tri	IN	SMBus address bit. This is a tri-level input that works in conjunction with the SMB_A0 to decode 1 of 9 SMBus Addresses.
15	DFB_IN	IN	True half of differential feedback input, provides feedback signal to the PLL for synchronization with the input clock to eliminate phase error.
16	DFB_IN#	IN	Complementary half of differential feedback input, provides feedback signal to the PLL for synchronization with input clock to eliminate phase error.
17	DFB_OUT#	OUT	Complementary half of differential feedback output, provides feedback signal to the PLL for synchronization with input clock to eliminate phase error.
18	DFB_OUT	OUT	True half of differential feedback output, provides feedback signal to the PLL for synchronization with the input clock to eliminate phase error.
19	DIF_0	OUT	0.7V differential true clock output
20	DIF_0#	OUT	0.7V differential Complementary clock output
21	VDD	PWR	Power supply, nominal 3.3V
22	DIF_1	OUT	0.7V differential true clock output
23	DIF_1#	OUT	0.7V differential Complementary clock output
24	DIF_2	OUT	0.7V differential true clock output
25	DIF_2#	OUT	0.7V differential Complementary clock output
26	GND	PWR	Ground pin.
27	DIF_3	OUT	0.7V differential true clock output
28	DIF_3#	OUT	0.7V differential Complementary clock output
29	DIF_4	OUT	0.7V differential true clock output
30	DIF_4#	OUT	0.7V differential Complementary clock output
31	VDD	PWR	Power supply, nominal 3.3V
32	DIF_5	OUT	0.7V differential true clock output
33	DIF_5#	OUT	0.7V differential Complementary clock output
34	OE5#	IN	Active low input for enabling DIF pair 5. 1 =disable outputs, 0 = enable outputs
35	DIF_6	OUT	0.7V differential true clock output
36	DIF_6#	OUT	0.7V differential Complementary clock output

Pin Description (continued)

PIN #	PIN NAME	PIN TYPE	DESCRIPTION
37	OE6#	IN	Active low input for enabling DIF pair 6. 1 =disable outputs, 0 = enable outputs
38	DIF_7	OUT	0.7V differential true clock output
39	DIF_7#	OUT	0.7V differential Complementary clock output
40	OE7#	IN	Active low input for enabling DIF pair 7. 1 =disable outputs, 0 = enable outputs
41	DIF_8	OUT	0.7V differential true clock output
42	DIF_8#	OUT	0.7V differential Complementary clock output
43	OE8#	IN	Active low input for enabling DIF pair 8. 1 =disable outputs, 0 = enable outputs
44	GND	PWR	Ground pin.
45	VDD	PWR	Power supply, nominal 3.3V
46	DIF_9	OUT	0.7V differential true clock output
47	DIF_9#	OUT	0.7V differential Complementary clock output
48	OE9#	IN	Active low input for enabling DIF pair 9. 1 =disable outputs, 0 = enable outputs
49	DIF_10	OUT	0.7V differential true clock output
50	DIF_10#	OUT	0.7V differential Complementary clock output
51	OE10#	IN	Active low input for enabling DIF pair 10. 1 =disable outputs, 0 = enable outputs
52	DIF_11	OUT	0.7V differential true clock output
53	DIF_11#	OUT	0.7V differential Complementary clock output
54	OE11#	IN	Active low input for enabling DIF pair 11. 1 =disable outputs, 0 = enable outputs
55	DIF_12	OUT	0.7V differential true clock output
56	DIF_12#	OUT	0.7V differential Complementary clock output
57	OE12#	IN	Active low input for enabling DIF pair 12. 1 =disable outputs, 0 = enable outputs
58	VDD	PWR	Power supply, nominal 3.3V
59	DIF_13	OUT	0.7V differential true clock output
60	DIF_13#	OUT	0.7V differential Complementary clock output
61	DIF_14	OUT	0.7V differential true clock output
62	DIF_14#	OUT	0.7V differential Complementary clock output
63	GND	PWR	Ground pin.
64	DIF_15	OUT	0.7V differential true clock output
65	DIF_15#	OUT	0.7V differential Complementary clock output
66	DIF_16	OUT	0.7V differential true clock output
67	DIF_16#	OUT	0.7V differential Complementary clock output
68	VDD	PWR	Power supply, nominal 3.3V
69	DIF_17	OUT	0.7V differential true clock output
70	DIF_17#	OUT	0.7V differential Complementary clock output
71	DIF_18	OUT	0.7V differential true clock output
72	DIF_18#	OUT	0.7V differential Complementary clock output

Electrical Characteristics - Absolute Maximum Ratings

PARAMETER	SYMBOL	CONDITIONS	MIN	TYP	MAX	UNITS	NOTES
3.3V Core Supply Voltage	VDDA				4.6	V	1,2
3.3V Logic Supply Voltage	VDD				4.6	V	1,2
Input Low Voltage	V _{IL}		GND-0.5			V	1
Input High Voltage	V _{IH}	Except for SMBus interface			V _{DD} +0.5V	V	1
Input High Voltage	V _{IHSMB}	SMBus clock and data pins			5.5V	V	1
Storage Temperature	T _s		-65		150	°C	1
Junction Temperature	T _j				125	°C	1
Case Temperature	T _c				110	°C	1
Input ESD protection	ESD prot	Human Body Model	2000			V	1

¹Guaranteed by design and characterization, not 100% tested in production.

²Operation under these conditions is neither implied nor guaranteed.

Electrical Characteristics - Input/Supply/Common Parameters

T_A = T_{COM}, Supply Voltage VDD/VDDA = 3.3 V +/-5%, See Test Loads for Loading Conditions

PARAMETER	SYMBOL	CONDITIONS	MIN	TYP	MAX	UNITS	NOTES
Ambient Operating Temperature	T _{COM}	Commercial range	0		70	°C	1
Input High Voltage	V _{IH}	Single-ended inputs, except SMBus, low threshold and tri-level inputs	2		V _{DD} + 0.3	V	1
Input Low Voltage	V _{IL}	Single-ended inputs, except SMBus, low threshold and tri-level inputs	GND - 0.3		0.8	V	1
Input Current	I _{IN}	Single-ended inputs, V _{IN} = GND, V _{IN} = VDD	-5		5	uA	1
	I _{INP}	Single-ended inputs V _{IN} = 0 V; Inputs with internal pull-up resistors V _{IN} = VDD; Inputs with internal pull-down resistors	-200		200	uA	1
Input Frequency	F _{ibyp}	V _{DD} = 3.3 V, Bypass mode	33		400	MHz	2
	F _{ipll}	V _{DD} = 3.3 V, 100MHz PLL mode	90	100.00	105	MHz	2
	F _{ipll}	V _{DD} = 3.3 V, 133.33MHz PLL mode	120	133.33	140	MHz	2
Pin Inductance	L _{pin}				7	nH	1
Capacitance	C _{IN}	Logic Inputs, except DIF_IN	1.5		5	pF	1
	C _{INDIF_IN}	DIF_IN differential clock inputs	1.5		2.7	pF	1,4
	C _{OUT}	Output pin capacitance			6	pF	1
Clk Stabilization	T _{STAB}	From V _{DD} Power-Up and after input clock stabilization or de-assertion of PD# to 1st clock			1.8	ms	1,2
Input SS Modulation Frequency	f _{MODIN}	Allowable Frequency (Triangular Modulation)	30		33	kHz	1
OE# Latency	t _{LATOE#}	DIF start after OE# assertion DIF stop after OE# deassertion	4		12	clocks	1,3
Tdrive_PD#	t _{DRVPD}	DIF output enable after PD# de-assertion			300	us	1,3
Tfall	t _F	Fall time of control inputs			5	ns	1,2
Trise	t _R	Rise time of control inputs			5	ns	1,2
SMBus Input Low Voltage	V _{ILSMB}				0.8	V	1
SMBus Input High Voltage	V _{IHSMB}		2.1		V _{DD} SMB	V	1
SMBus Output Low Voltage	V _{OLSMB}	@ I _{PULLUP}			0.4	V	1
SMBus Sink Current	I _{PULLUP}	@ V _{OL}	4			mA	1
Nominal Bus Voltage	V _{DD} SMB	3V to 5V +/- 10%	2.7		5.5	V	1
SCLK/SDATA Rise Time	t _{RSMB}	(Max V _{IL} - 0.15) to (Min V _{IH} + 0.15)			1000	ns	1
SCLK/SDATA Fall Time	t _{FSMB}	(Min V _{IH} + 0.15) to (Max V _{IL} - 0.15)			300	ns	1
SMBus Operating Frequency	f _{MAXSMB}	Maximum SMBus operating frequency			100	kHz	1,5

¹Guaranteed by design and characterization, not 100% tested in production.

²Control input must be monotonic from 20% to 80% of input swing.

³Time from deassertion until outputs are >200 mV

⁴DIF_IN input

⁵The differential input clock must be running for the SMBus to be active

Electrical Characteristics - DIF_IN Clock Input Parameters

$T_{AMB}=T_{COM}$ unless otherwise indicated, Supply Voltages per normal operation conditions, See Test Loads for Loading Conditions

PARAMETER	SYMBOL	CONDITIONS	MIN	TYP	MAX	UNITS	NOTES
Input Crossover Voltage - DIF_IN	V_{CROSS}	Cross Over Voltage	150		900	mV	1
Input Swing - DIF_IN	V_{SWING}	Differential value	300			mV	1
Input Slew Rate - DIF_IN	dv/dt	Measured differentially	0.4		8	V/ns	1,2
Input Leakage Current	I_{IN}	$V_{IN} = V_{DD}, V_{IN} = GND$	-5		5	μA	
Input Duty Cycle	d_{tin}	Measurement from differential waveform	45		55	%	1
Input Jitter - Cycle to Cycle	J_{DIFin}	Differential Measurement	0		125	ps	1

¹ Guaranteed by design and characterization, not 100% tested in production.

² Slew rate measured through +/-75mV window centered around differential zero

Electrical Characteristics - DIF 0.7V Current Mode Differential Outputs

$T_A = T_{COM}$, Supply Voltage $V_{DD}/V_{DDA} = 3.3 V \pm 5\%$, See Test Loads for Loading Conditions

PARAMETER	SYMBOL	CONDITIONS	MIN	TYP	MAX	UNITS	NOTES
Slew rate	dV/dt	Scope averaging on	1	2.5	4	V/ns	1, 2, 3
Slew rate matching	$\Delta dV/dt$	Slew rate matching, Scope averaging on			20	%	1, 2, 4
Rise/Fall Time Matching	τ_{Trf}	Rise/fall matching, Scope averaging off			125	ps	1, 7, 8
Voltage High	V_{High}	Statistical measurement on single-ended signal using oscilloscope math function. (Scope averaging on)	660	750	850	mV	1
Voltage Low	V_{Low}		-150		150		1
Max Voltage	V_{max}	Measurement on single ended signal using absolute value. (Scope averaging off)			1150	mV	1
Min Voltage	V_{min}		-300				1
Vswing	V_{swing}	Scope averaging off	300			mV	1, 2
Crossing Voltage (abs)	V_{cross_abs}	Scope averaging off	250		550	mV	1, 5
Crossing Voltage (var)	ΔV_{cross}	Scope averaging off			140	mV	1, 6

¹ Guaranteed by design and characterization, not 100% tested in production. $I_{REF} = V_{DD}/(3 \times R_R)$. For $R_R = 475\Omega$ (1%), $I_{REF} = 2.32mA$.

$I_{OH} = 6 \times I_{REF}$ and $V_{OH} = 0.7V @ Z_O=50\Omega$ (100 Ω differential impedance).

² Measured from differential waveform

³ Slew rate is measured through the V_{swing} voltage range centered around differential 0V. This results in a +/-150mV window around differential 0V.

⁴ Matching applies to rising edge rate for Clock and falling edge rate for Clock#. It is measured using a +/-75mV window centered on the average cross point where Clock rising meets Clock# falling. The median cross point is used to calculate the voltage thresholds the oscilloscope is to use for the edge rate calculations.

⁵ V_{cross} is defined as voltage where Clock = Clock# measured on a component test board and only applies to the differential rising edge (i.e. Clock rising and Clock# falling).

⁶ The total variation of all V_{cross} measurements in any particular system. Note that this is a subset of $V_{cross_min/max}$ (V_{cross} absolute) allowed. The intent is to limit V_{cross} induced modulation by setting V_{cross_delta} to be smaller than V_{cross} absolute.

⁷ Measured from single-ended waveform

⁸ Measured with scope averaging off, using statistics function. Variation is difference between min and max.

Electrical Characteristics - Current ConsumptionTA = T_{COM}; Supply Voltage VDD/VDDA = 3.3 V +/-5%, See Test Loads for Loading Conditions

PARAMETER	SYMBOL	CONDITIONS	MIN	TYP	MAX	UNITS	NOTES
Operating Supply Current	I _{DD3.3OP}	All outputs active @100MHz, C _L = Full load;		407	500	mA	1
Powerdown Current	I _{DD3.3PDZ}	All differential pairs tri-stated		12	36	mA	1

¹Guaranteed by design and characterization, not 100% tested in production.**Electrical Characteristics - Skew and Differential Jitter Parameters**TA = T_{COM}; Supply Voltage VDD/VDDA = 3.3 V +/-5%, See Test Loads for Loading Conditions

PARAMETER	SYMBOL	CONDITIONS	MIN	TYP	MAX	UNITS	NOTES
CLK_IN, DIF[x:0]	t _{SPO_PLL}	Input-to-Output Skew in PLL mode nominal value @ 25°C, 3.3V	-300	-200	-100	ps	1,2,4,5,8
CLK_IN, DIF[x:0]	t _{PD_BYP}	Input-to-Output Skew in Bypass mode nominal value @ 25°C, 3.3V	2.5	3.5	4.5	ns	1,2,3,5,8
CLK_IN, DIF[x:0]	t _{DSPO_PLL}	Input-to-Output Skew Variation in PLL mode across voltage and temperature	-50	0	50	ps	1,2,3,5,8
CLK_IN, DIF[x:0]	t _{DSPO_BYP}	Input-to-Output Skew Variation in Bypass mode across voltage and temperature	-250		250	ps	1,2,3,5,8
CLK_IN, DIF[x:0]	t _{DTE}	Random Differential Tracking error between two 9ZX devices in Hi BW Mode		3	5	ps (rms)	1,2,3,5,8
CLK_IN, DIF[x:0]	t _{DSSTE}	Random Differential Spread Spectrum Tracking error between two 9ZX devices in Hi BW Mode		15	75	ps	1,2,3,5,8
DIF[x:0]	t _{SKEW_ALL}	Output-to-Output Skew across all outputs (Common to Bypass and PLL mode)		45	65	ps	1,2,3,8
PLL Jitter Peaking	j _{peak-hibw}	LOBW#_BYPASS_HIBW = 1	0	1	2.5	dB	7,8
PLL Jitter Peaking	j _{peak-lobw}	LOBW#_BYPASS_HIBW = 0	0	1	2	dB	7,8
PLL Bandwidth	p _{ll_HIBW}	LOBW#_BYPASS_HIBW = 1	2	3	4	MHz	8,9
PLL Bandwidth	p _{ll_LOBW}	LOBW#_BYPASS_HIBW = 0	0.7	1	1.4	MHz	8,9
Duty Cycle	t _{DC}	Measured differentially, PLL Mode	45	50	55	%	1
Duty Cycle Distortion	t _{DCD}	Measured differentially, Bypass Mode @100MHz	-2	0	2	%	1,10
Jitter, Cycle to cycle	t _{jcy-cyc}	PLL mode		24	50	ps	1,11
		Additive Jitter in Bypass Mode		20	50	ps	1,11

Notes for preceding table:¹ Measured into fixed 2 pF load cap. Input to output skew is measured at the first output edge following the corresponding input. Feedback path is 695 mils long.² Measured from differential cross-point to differential cross-point. This parameter can be tuned with external feedback path, if present.³ All Bypass Mode Input-to-Output specs refer to the timing between an input edge and the specific output edge created by it.⁴ This parameter is deterministic for a given device⁵ Measured with scope averaging on to find mean value. DIF_IN slew rate must be matched to DIF output slew rate.⁶ t is the period of the input clock⁷ Measured as maximum pass band gain. At frequencies within the loop BW, highest point of magnification is called PLL jitter peaking.⁸ Guaranteed by design and characterization, not 100% tested in production.⁹ Measured at 3 db down or half power point.¹⁰ Duty cycle distortion is the difference in duty cycle between the output and the input clock when the device is operated in bypass mode.¹¹ Measured from differential waveform

Electrical Characteristics - Phase Jitter Parameters

TA = T_{COM}; Supply Voltage VDD/VDDA = 3.3 V +/-5%, See Test Loads for Loading Conditions

PARAMETER	SYMBOL	CONDITIONS	MIN	TYP	MAX	UNITS	Notes
Jitter, Phase	t _{jphPCIeG1}	PCIe Gen 1		36	86	ps (p-p)	1,2,3
	t _{jphPCIeG2}	PCIe Gen 2 Lo Band 10kHz < f < 1.5MHz		1.2	3	ps (rms)	1,2
		PCIe Gen 2 High Band 1.5MHz < f < Nyquist (50MHz)		1.9	3.1	ps (rms)	1,2
	t _{jphPCIeG3}	PCIe Gen 3 (PLL BW of 2-4MHz, CDR = 10MHz)		0.5	1	ps (rms)	1,2,4
	t _{jphQPI_SMI}	QPI & SMI (100MHz or 133MHz, 4.8Gb/s, 6.4Gb/s 12UI)		0.31	0.5	ps (rms)	1,5
		QPI & SMI (100MHz, 8.0Gb/s, 12UI)		0.21	0.3	ps (rms)	1,5
		QPI & SMI (100MHz, 9.6Gb/s, 12UI)		0.17	0.2	ps (rms)	1,5
Additive Phase Jitter, Bypass mode	t _{jphPCIeG1}	PCIe Gen 1		4	10	ps (p-p)	1,2,3
	t _{jphPCIeG2}	PCIe Gen 2 Lo Band 10kHz < f < 1.5MHz		0.25	0.3	ps (rms)	1,2,6
		PCIe Gen 2 High Band 1.5MHz < f < Nyquist (50MHz)		0.57	0.7	ps (rms)	1,2,6
	t _{jphPCIeG3}	PCIe Gen 3 (PLL BW of 2-4MHz, CDR = 10MHz)		0.20	0.3	ps (rms)	1,2,4,6
	t _{jphQPI_SMI}	QPI & SMI (100MHz or 133MHz, 4.8Gb/s, 6.4Gb/s 12UI)		0.22	0.3	ps (rms)	1,5,6
		QPI & SMI (100MHz, 8.0Gb/s, 12UI)		0.08	0.1	ps (rms)	1,5,6
		QPI & SMI (100MHz, 9.6Gb/s, 12UI)		0.08	0.1	ps (rms)	1,5,6

¹ Applies to all outputs.

² See <http://www.pcisiq.com> for complete specs

³ Sample size of at least 100K cycles. This figures extrapolates to 108ps pk-pk @ 1M cycles for a BER of 1-12.

⁴ Subject to final radification by PCI SIG.

⁵ Calculated from Intel-supplied Clock Jitter Tool v 1.6.3

⁶ For RMS figures, additive jitter is calculated by solving the following equation: (Additive jitter)² = (total jitter)² - (input jitter)²

Clock Periods - Differential Outputs with Spread Spectrum Disabled

SSC OFF	Center Freq. MHz	Measurement Window							Units	Notes
		1 Clock	1us	0.1s	0.1s	0.1s	1us	1 Clock		
		-c2c jitter AbsPer Min	-SSC Short-Term Average Min	- ppm Long-Term Average Min	0 ppm Period Nominal	+ ppm Long-Term Average Max	+SSC Short-Term Average Max	+c2c jitter AbsPer Max		
DIF	100.00	9.94900		9.99900	10.00000	10.00100		10.05100	ns	1,2,3
	133.33	7.44925		7.49925	7.50000	7.50075		7.55075	ns	1,2,4

Clock Periods - Differential Outputs with Spread Spectrum Enabled

SSC ON	Center Freq. MHz	Measurement Window							Units	Notes
		1 Clock	1us	0.1s	0.1s	0.1s	1us	1 Clock		
		-c2c jitter AbsPer Min	-SSC Short-Term Average Min	- ppm Long-Term Average Min	0 ppm Period Nominal	+ ppm Long-Term Average Max	+SSC Short-Term Average Max	+c2c jitter AbsPer Max		
DIF	99.75	9.94906	9.99906	10.02406	10.02506	10.02607	10.05107	10.10107	ns	1,2,3
	133.00	7.44930	7.49930	7.51805	7.51880	7.51955	7.53830	7.58830	ns	1,2,4

Notes:

- ¹Guaranteed by design and characterization, not 100% tested in production.
- ²All Long Term Accuracy specifications are guaranteed with the assumption that the input clock complies with CK420BQ/CK410B+ accuracy requirements (+/-100ppm). The 9ZX21901 itself does not contribute to ppm error.
- ³Driven by SRC output of main clock, 100 MHz PLL Mode or Bypass mode
- ⁴Driven by CPU output of main clock, 133 MHz PLL Mode or Bypass mode

Power Management Table

Inputs		Control Bits/Pins				Outputs	PLL State
CKPWRGD_PD#	DIF_IN/ DIF_IN#	SMBus EN bit	OE# Pin	DIF(5:12)/ DIF(5:12)#	Other DIF/ DIF#	DFB_OUT/ DFB_OUT#	
0	X	X	X	Hi-Z ¹	Hi-Z ¹	Hi-Z ¹	OFF
1	Running	0	X	Hi-Z ¹	Hi-Z ¹	Running	ON
		1	0	Running	Running	Running	ON
		1	1	Hi-Z ¹	Running	Running	ON

NOTE:

- 1. Due to external pull down resistors, HI-Z results in Low/Low on the True/Complement outputs

Thermal Characteristics

Parameter	Symbol	Conditions	Min.	Typ.	Max.	Units
Thermal Resistance Junction to Ambient	θJA	Still air		26.2		°C/W
	θJA	1 m/s air flow		23.1		°C/W
	θJA	3 m/s air flow		19.6		°C/W
Thermal Resistance Junction to Case	θJC			10.4		°C/W
Thermal Resistance Junction to Board	θJB			0.3		°C/W

9ZX21901 Differential Test Loads

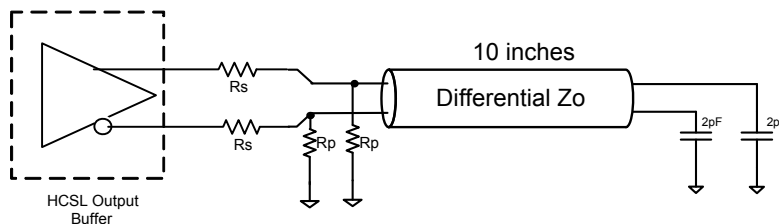

Differential Output Termination Table

DIF Zo (Ω)	Iref (Ω)	Rs (Ω)	Rp (Ω)
100	475	33	50
85	412	27	42.2 or 43.2

General SMBus serial interface information for the 9ZX21901B (See also 9ZX21901 SMBus Addressing on page 2)

How to Write:

- Controller (host) sends a start bit.
- Controller (host) sends the write address $XX_{(H)}$
- IDT clock will **acknowledge**
- Controller (host) sends the beginning byte location = N
- IDT clock will **acknowledge**
- Controller (host) sends the data byte count = X
- IDT clock will **acknowledge**
- Controller (host) starts sending **Byte N through Byte N + X - 1**
- IDT clock will **acknowledge** each byte **one at a time**
- Controller (host) sends a Stop bit

How to Read:

- Controller (host) will send start bit.
- Controller (host) sends the write address $XX_{(H)}$
- IDT clock will **acknowledge**
- Controller (host) sends the beginning byte location = N
- IDT clock will **acknowledge**
- Controller (host) will send a separate start bit.
- Controller (host) sends the read address $YY_{(H)}$
- IDT clock will **acknowledge**
- vclock will send the data byte count = X
- IDT clock sends **Byte N + X - 1**
- IDT clock sends **Byte 0 through byte X (if $X_{(H)}$ was written to byte 8).**
- Controller (host) will need to acknowledge each byte
- Controller (host) will send a not acknowledge bit
- Controller (host) will send a stop bit

Index Block Write Operation		
Controller (Host)		IDT (Slave/Receiver)
T	starT bit	
Slave Address $XX_{(H)}$		
WR	WRite	
		ACK
Beginning Byte = N		
		ACK
Data Byte Count = X		
		ACK
Beginning Byte N	X Byte	
◇		ACK
◇		◇
◇		◇
Byte N + X - 1		◇
		ACK
P	stoP bit	

Index Block Read Operation		
Controller (Host)		IDT (Slave/Receiver)
T	starT bit	
Slave Address $XX_{(H)}$		
WR	WRite	
		ACK
Beginning Byte = N		
		ACK
RT	Repeat starT	
Slave Address $YY_{(H)}$		
RD	ReaD	
		ACK
		Data Byte Count = X
ACK		
		Beginning Byte N
ACK		
◇		X Byte
◇		
◇		
◇		
		Byte N + X - 1
N	Not acknowledge	
P	stoP bit	

Note: $XX_{(H)}$ is defined by SMBus address select pins

SMBusTable: PLL Mode, and Frequency Select Register

Byte 0	Pin #	Name	Control Function	Type	0	1	Default
Bit 7	5	PLL Mode 1	PLL Operating Mode Rd back 1	R	See PLL Operating Mode Readback Table		Latch
Bit 6	5	PLL Mode 0	PLL Operating Mode Rd back 0	R			Latch
Bit 5	72/71	DIF_18_En	Output Control overrides OE# pin	RW	Hi-Z	Enable	1
Bit 4	70/69	DIF_17_En	Output Control overrides OE# pin	RW	Hi-Z	Enable	1
Bit 3	67/66	DIF_16_En	Output Control overrides OE# pin	RW	Hi-Z	Enable	1
Bit 2			Reserved				0
Bit 1			Reserved				0
Bit 0	4	100M_133M#	Frequency Select Readback	R	133MHz	100MHz	Latch

SMBusTable: Output Control Register

Byte 1	Pin #	Name	Control Function	Type	0	1	Default
Bit 7	39/38	DIF_7_En	Output Control overrides OE# pin	RW	Hi-Z	Enable	1
Bit 6	35/36	DIF_6_En	Output Control overrides OE# pin	RW			1
Bit 5	32/33	DIF_5_En	Output Control overrides OE# pin	RW			1
Bit 4	29/30	DIF_4_En	Output Control overrides OE# pin	RW			1
Bit 3	27/28	DIF_3_En	Output Control overrides OE# pin	RW			1
Bit 2	24/25	DIF_2_En	Output Control overrides OE# pin	RW			1
Bit 1	22/23	DIF_1_En	Output Control overrides OE# pin	RW			1
Bit 0	19/20	DIF_0_En	Output Control overrides OE# pin	RW			1

SMBusTable: Output Control Register

Byte 2	Pin #	Name	Control Function	Type	0	1	Default
Bit 7	65/64	DIF_15_En	Output Control overrides OE# pin	RW	Hi-Z	Enable	1
Bit 6	62/61	DIF_14_En	Output Control overrides OE# pin	RW			1
Bit 5	60/59	DIF_13_En	Output Control overrides OE# pin	RW			1
Bit 4	56/55	DIF_12_En	Output Control overrides OE# pin	RW			1
Bit 3	53/52	DIF_11_En	Output Control overrides OE# pin	RW			1
Bit 2	50/49	DIF_10_En	Output Control overrides OE# pin	RW			1
Bit 1	47/46	DIF_9_En	Output Control overrides OE# pin	RW			1
Bit 0	42/41	DIF_8_En	Output Control overrides OE# pin	RW			1

SMBusTable: Output Enable Pin Status Readback Register

Byte 3	Pin #	Name	Control Function	Type	0	1	Default
Bit 7	57	OE_RB12	Real Time readback of OE#12	R	OE# pin Low	OE# Pin High	Real time
Bit 6	54	OE_RB11	Real Time readback of OE#11	R			Real time
Bit 5	51	OE_RB10	Real Time readback of OE#10	R			Real time
Bit 4	48	OE_RB9	Real Time readback of OE#9	R			Real time
Bit 3	43	OE_RB8	Real Time readback of OE#8	R			Real time
Bit 2	40	OE_RB7	Real Time readback of OE#7	R			Real time
Bit 1	37	OE_RB6	Real Time readback of OE#6	R			Real time
Bit 0	34	OE_RB5	Real Time readback of OE#5	R			Real time

SMBusTable: Reserved Register

Byte 4	Pin #	Name	Control Function	Type	0	1	Default
Bit 7			Reserved				0
Bit 6			Reserved				0
Bit 5			Reserved				0
Bit 4			Reserved				0
Bit 3			Reserved				0
Bit 2			Reserved				0
Bit 1			Reserved				0
Bit 0			Reserved				0

SMBusTable: Vendor & Revision ID Register

Byte 5	Pin #	Name	Control Function	Type	0	1	Default
Bit 7	-	RID3	REVISION ID	R	B rev = 0001 C Rev = 0010		X
Bit 6	-	RID2		R			X
Bit 5	-	RID1		R			X
Bit 4	-	RID0		R			X
Bit 3	-	VID3	VENDOR ID	R	-	-	0
Bit 2	-	VID2		R	-	-	0
Bit 1	-	VID1		R	-	-	0
Bit 0	-	VID0		R	-	-	1

SMBusTable: DEVICE ID

Byte 6	Pin #	Name	Control Function	Type	0	1	Default
Bit 7	-		Device ID 7 (MSB)	R	Device ID is 219 decimal or DB hex.		1
Bit 6	-		Device ID 6	R			1
Bit 5	-		Device ID 5	R			0
Bit 4	-		Device ID 4	R			1
Bit 3	-		Device ID 3	R			1
Bit 2	-		Device ID 2	R			0
Bit 1	-		Device ID 1	R			1
Bit 0	-		Device ID 0	R			1

SMBusTable: Byte Count Register

Byte 7	Pin #	Name	Control Function	Type	0	1	Default
Bit 7			Reserved				0
Bit 6			Reserved				0
Bit 5			Reserved				0
Bit 4	-	BC4	Writing to this register configures how many bytes will be read back.	RW	Default value is 8 hex, so 9 bytes (0 to 8) will be read back by default.		0
Bit 3	-	BC3		RW			1
Bit 2	-	BC2		RW			0
Bit 1	-	BC1		RW			0
Bit 0	-	BC0		RW			0

SMBusTable: Reserved Register

Byte 8	Pin #	Name	Control Function	Type	0	1	Default
Bit 7			Reserved				0
Bit 6			Reserved				0
Bit 5			Reserved				0
Bit 4			Reserved				0
Bit 3			Reserved				0
Bit 2			Reserved				0
Bit 1			Reserved				0
Bit 0			Reserved				0

DIF Reference Clock			
Common Recommendations for Differential Routing	Dimension or Value	Unit	Figure
L1 length, route as non-coupled 50ohm trace	0.5 max	inch	1
L2 length, route as non-coupled 50ohm trace	0.2 max	inch	1
L3 length, route as non-coupled 50ohm trace	0.2 max	inch	1
Rs	33	ohm	1
Rt	49.9	ohm	1

Down Device Differential Routing			
L4 length, route as coupled microstrip 100ohm differential trace	2 min to 16 max	inch	1
L4 length, route as coupled stripline 100ohm differential trace	1.8 min to 14.4 max	inch	1

Differential Routing to PCI Express Connector			
L4 length, route as coupled microstrip 100ohm differential trace	0.25 to 14 max	inch	2
L4 length, route as coupled stripline 100ohm differential trace	0.225 min to 12.6 max	inch	2

Figure 1: Down Device Routing

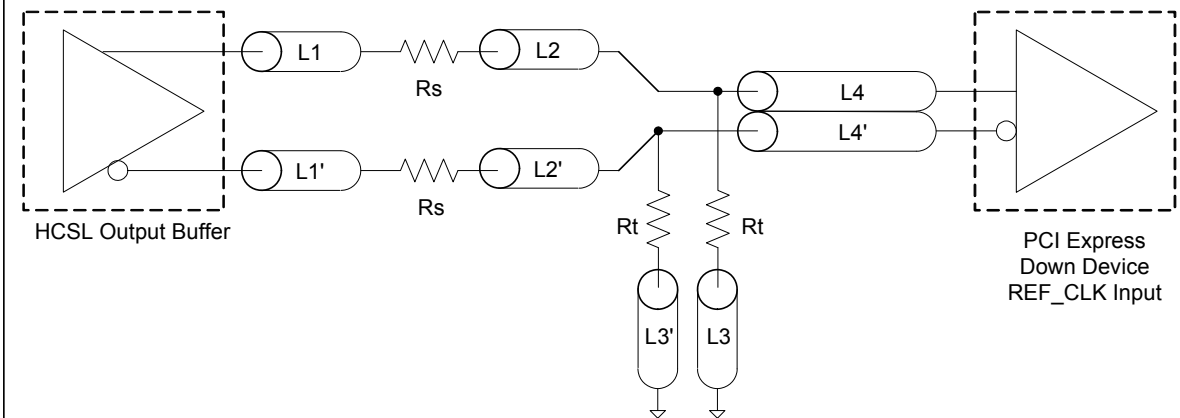
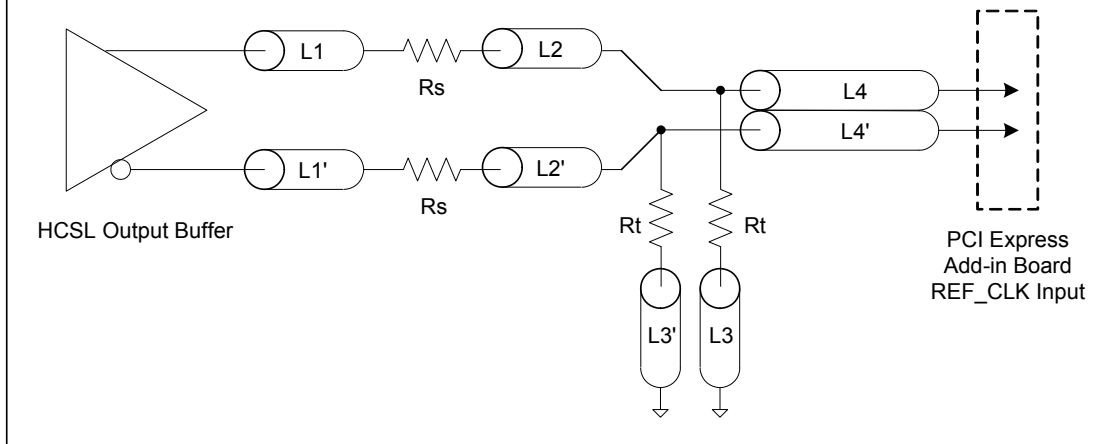

Figure 2: PCI Express Connector Routing



Alternative Termination for LVDS and other Common Differential Signals (figure 3)

Vdiff	Vp-p	Vcm	R1	R2	R3	R4	Note
0.45v	0.22v	1.08	33	150	100	100	
0.58	0.28	0.6	33	78.7	137	100	
0.80	0.40	0.6	33	78.7	none	100	ICS874003i-02 input compatible
0.60	0.3	1.2	33	174	140	100	Standard LVDS

R1a = R1b = R1

R2a = R2b = R2

Figure 3

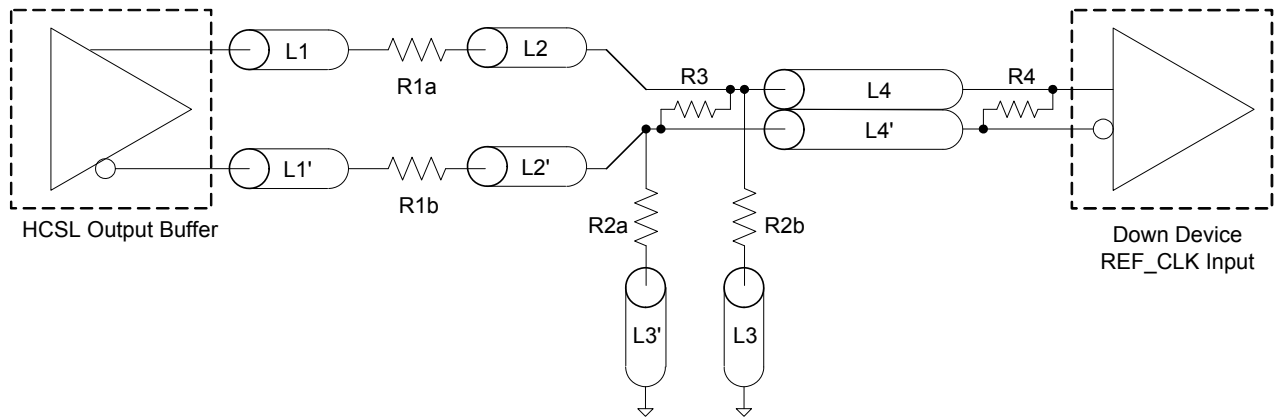

Cable Connected AC Coupled Application (figure 4)

Component	Value	Note
R5a, R5b	8.2K 5%	
R6a, R6b	1K 5%	
Cc	0.1 μ F	
Vcm	0.350 volts	

Figure 4

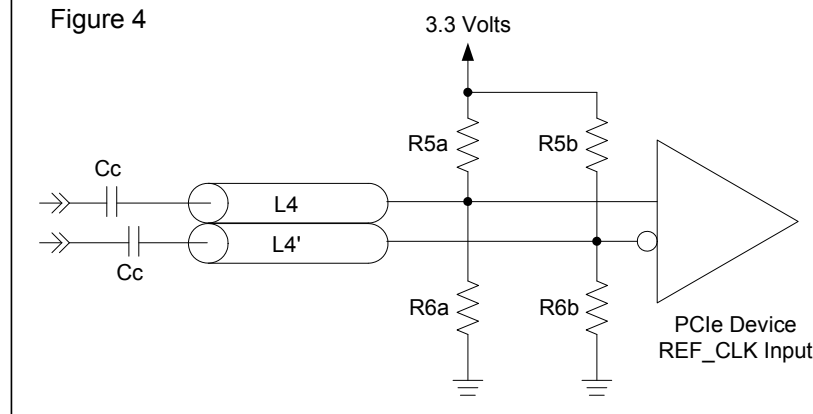

NL72 Package Drawing and Dimensions

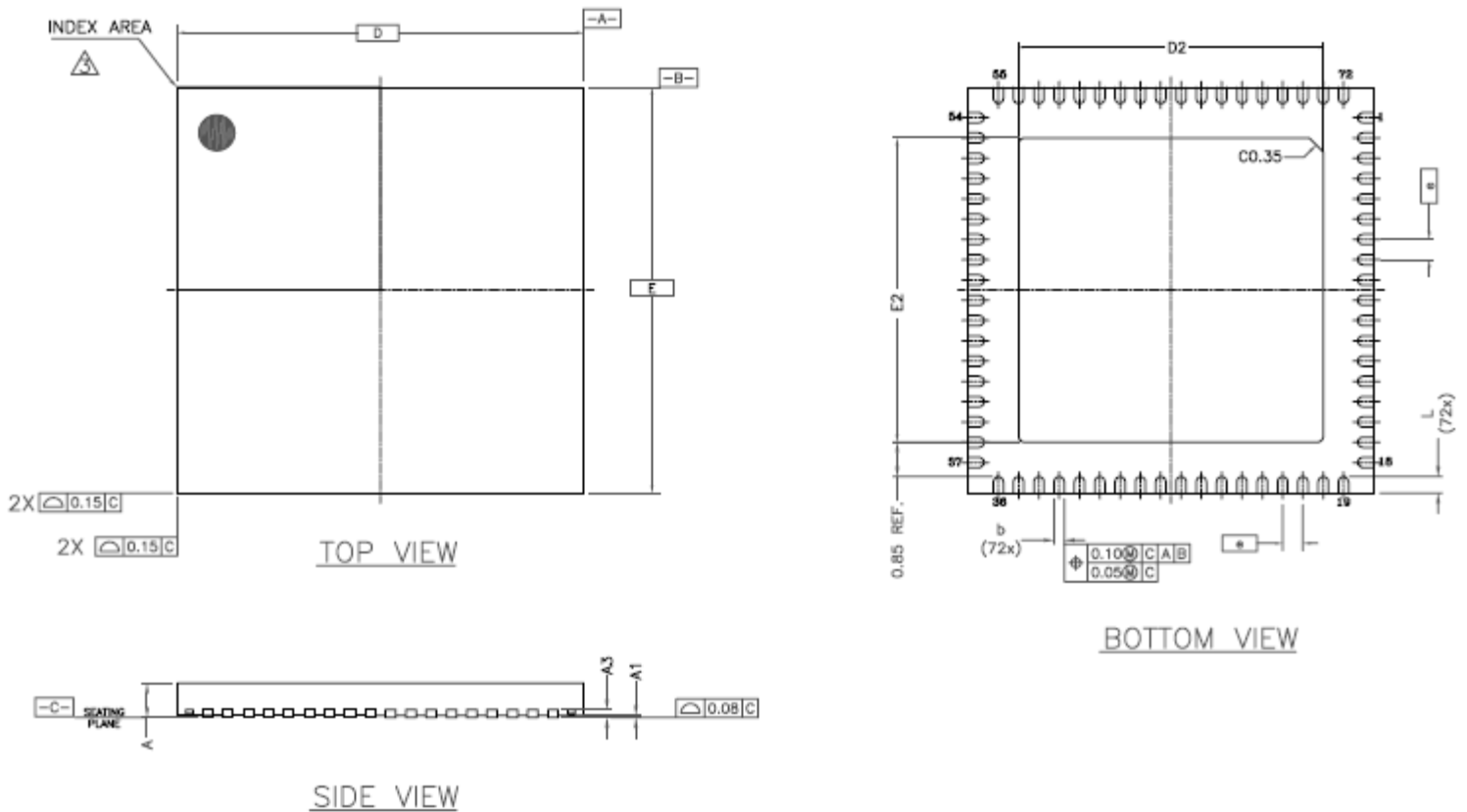

NOTES:

1. ALL DIMENSIONING AND TOLERANCING CONFORM TO ANSI Y14.5M-1982
2. ALL DIMENSIONS ARE IN MILLIMETERS.
3. INDEX AREA (PIN1 IDENTIFIER)

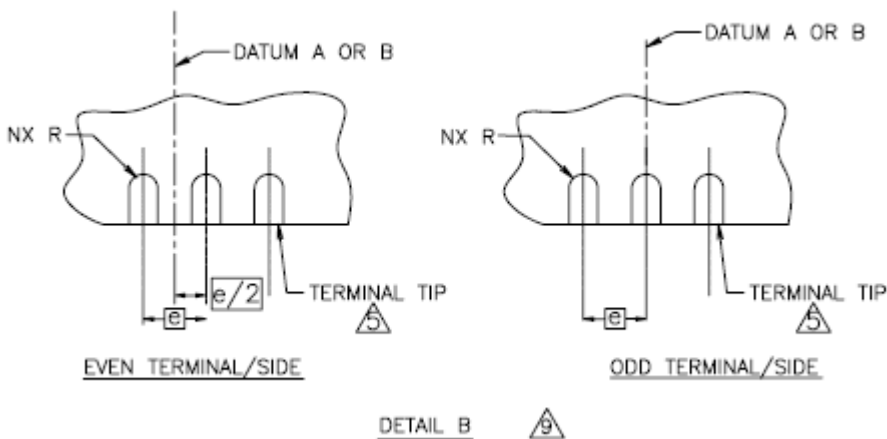

NL72 Package Drawing and Dimensions (cont.)

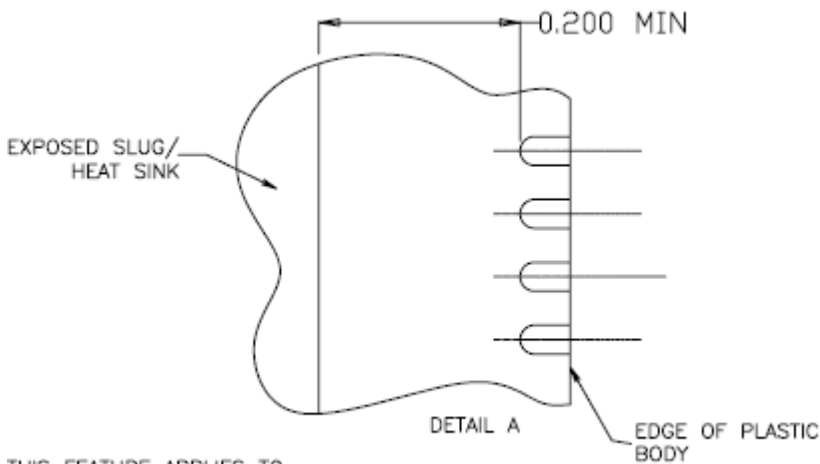

THIS FEATURE APPLIES TO ALL ENDS OF THE PKG.

COMMON DIMENSIONS			
DIM SYMBOL	MIN	NOM	MAX
A	0.80	0.90	1.00
A1	0	0.02	0.05
A3 REF	—	0.20 ref	—
Ø	0	—	14
T ref.	—	0.45	—
R1	—	0.20	—
R ref, b min/2			
NOTES	1,2		
b	0.18	0.25	0.30
Ⓞ	0.50 BSC		
d	10.00 BSC		
E	10.00 BSC		

SYMBOL	DIMENSION			NOTE
	MIN.	NOM.	MAX.	
D2	SEE EPAD OPTION			
E2	SEE EPAD OPTION			
k	0.20	—	—	
N		72		6
Nd		18		6
Ne		18		6

EPAD OPTION:

SYMBOL	P3		
	MIN.	NOM.	MAX.
E2	5.80	5.90	6.00
D2	5.80	5.90	6.00

TOLERANCE OF FORM & POSITION		
pitch SYMBOL	0.40mm	0.50mm
aaa	0.10	0.15
bbb	0.07	0.10
ccc	0.10	0.10
ddd	0.05	0.05
NOTES	1,2	

LEAD OPTION

SYMBOL	Z2		
	MIN.	NOM.	MAX.
L	0.30	0.40	0.50

NOTES:

- DIMENSIONING & TOLERANCING CONFORM TO ASME Y14.5M-1994.
- ALL DIMENSIONS ARE IN MILLIMETERS. ANGLES ARE IN DEGREES.
- N IS THE TOTAL NUMBER OF TERMINALS.
Nd IS THE NUMBER OF TERMINALS IN X-DIRECTION &
Ne IS THE NUMBER OF TERMINALS IN Y-DIRECTION.
- THE TERMINAL #1 IDENTIFIER AND TERMINAL NUMBERING CONVENTION SHALL CONFORM TO JEDEC PUB. 95 SEC. 4.3 SPP-002. DETAILS OF TERMINAL #1 IDENTIFIER ARE OPTIONAL, BUT MUST BE LOCATED WITHIN THE ZONE INDICATED. THE TERMINAL #1 IDENTIFIER MAY BE EITHER A MOLD OR MARKED FEATURE.
- DIMENSION b APPLIES TO METALLIZED TERMINAL AND IS MEASURED BETWEEN 0.25mm AND 0.30mm FROM TERMINAL TIP.
- ND AND NE REFER TO THE NUMBER OF TERMINALS ON EACH D AND E SIDE RESPECTIVELY.
- DEPOPULATION IS POSSIBLE IN A SYMMETRICAL FASHION.

Ordering Information

Part / Order Number	Shipping Package	Package	Temperature
9ZX21901BKLF	Trays	72-pin MLF	0 to +70°C
9ZX21901BKLFT	Tape and Reel	72-pin MLF	0 to +70°C

"LF" designates PB-free configuration, RoHS compliant.

Revision History

Rev.	Issue Date	Who	Description	Page #
A	5/13/2009	RDW	1. Slightly modified name of pin 6 and corrected pin description of pin 6, to remove reference to CK505 2. Added Typical numbers to key parameters in electrical characteristics tables. 3. Move to final.	Various
B	8/7/2009	RDW	1. Updated Pin 8 name to VDDR to indicate that it is the VDD for the input receiver. 2. Change MAX operating current from 600 to 500mA.	Various
C	8/12/2009	RDW	1. Updated VDDR pin description to include 3.3V information.	Various
D	8/14/2009	RDW	1. Inserted Pins 19 and 72 into pinout after they were inadvertently removed.	2
E	10/7/2009	RDW	1. Corrected units from ns to ps for the tDSPO_PLL and tDSPO_BYP parameters	
F	6/22/2010	RDW	1. Updated QPI reference to 9.6GTs, added note about variable feedback path 2. Reformatted electrical tables to fit new standard format 3. Merged Phase Jitter Tables into Single Table. 4. Added output termination/test load drawing and table	1, 5, 6, 9
G	8/3/2010	RDW	1. Updated front page to standard 9ZX format. 2. Clarified that SMBus Address Selection table includes the Read/Write Bit. Minor clarifications to other tables. 3. Added additive phase jitter table for bypass mode.	1-3, 5-11
H	3/2/2011	RDW	1. Added rise/fall variation spec to HCSL_Out table	6
J	12/8/2011	RDW	1. Updated tDSPO_BYP parameter from +/-350 to +/-250ps.	7
K	4/12/2012	RDW	1. Updated Rp values on Output Terminations Table from 43.2 ohms to 42.2 or 43.2 ohms to be consistent with Intel.	9
L	12/17/2012	RG	1. Updated Abs Max table to include Case Temperature at 110 °C max. 2. Added Thermal Characteristics table	5, 9
M	4/15/2013	RDW	1. Corrected typo in OE# Latency parameter; changed 1 min. to 3 max. cycles to 4 min. to 12 max. clocks.	5
N	1/7/2015	DC	Updated package drawing and dimensions from PUNCH to SAWN	Various
P	11/19/2015	RDW	Update Input Clock spec with new standardized table matching PCIe SIG input specs.	5

9ZX21901B

19-Output Differential Zbuffer for PCIe Gen2/3 and QPI

IMPORTANT NOTICE AND DISCLAIMER

RENESAS ELECTRONICS CORPORATION AND ITS SUBSIDIARIES (“RENESAS”) PROVIDES TECHNICAL SPECIFICATIONS AND RELIABILITY DATA (INCLUDING DATASHEETS), DESIGN RESOURCES (INCLUDING REFERENCE DESIGNS), APPLICATION OR OTHER DESIGN ADVICE, WEB TOOLS, SAFETY INFORMATION, AND OTHER RESOURCES “AS IS” AND WITH ALL FAULTS, AND DISCLAIMS ALL WARRANTIES, EXPRESS OR IMPLIED, INCLUDING, WITHOUT LIMITATION, ANY IMPLIED WARRANTIES OF MERCHANTABILITY, FITNESS FOR A PARTICULAR PURPOSE, OR NON-INFRINGEMENT OF THIRD PARTY INTELLECTUAL PROPERTY RIGHTS.

These resources are intended for developers skilled in the art designing with Renesas products. You are solely responsible for (1) selecting the appropriate products for your application, (2) designing, validating, and testing your application, and (3) ensuring your application meets applicable standards, and any other safety, security, or other requirements. These resources are subject to change without notice. Renesas grants you permission to use these resources only for development of an application that uses Renesas products. Other reproduction or use of these resources is strictly prohibited. No license is granted to any other Renesas intellectual property or to any third party intellectual property. Renesas disclaims responsibility for, and you will fully indemnify Renesas and its representatives against, any claims, damages, costs, losses, or liabilities arising out of your use of these resources. Renesas' products are provided only subject to Renesas' Terms and Conditions of Sale or other applicable terms agreed to in writing. No use of any Renesas resources expands or otherwise alters any applicable warranties or warranty disclaimers for these products.

(Rev.1.0 Mar 2020)

Corporate Headquarters

TOYOSU FORESIA, 3-2-24 Toyosu,
Koto-ku, Tokyo 135-0061, Japan
www.renesas.com

Contact Information

For further information on a product, technology, the most up-to-date version of a document, or your nearest sales office, please visit:
www.renesas.com/contact/

Trademarks

Renesas and the Renesas logo are trademarks of Renesas Electronics Corporation. All trademarks and registered trademarks are the property of their respective owners.