

● **General Description**

The TF60N02 combines advanced trench MOSFET technology with a low resistance package to provide extremely low $R_{DS(ON)}$. This device is ideal for load switch and battery protection applications.

● **Features**

- Advance high cell density Trench technology
- Low $R_{DS(ON)}$ to minimize conductive loss
- Low Gate Charge for fast switching
- Low Thermal resistance

● **Application**

- MB/VGA Vcore
- SMPS 2nd Synchronous Rectifier
- POL application
- BLDC Motor driver

● **Product Summary**

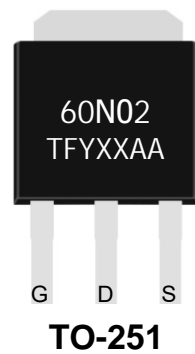
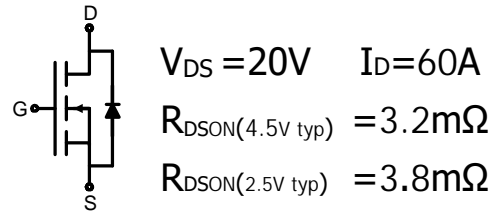

● **Ordering Information:**

Part NO.	TF60N02
Marking 1	60N02
Marking 2	TF:tuofeng; Y:year code; X:Week; AA:device code;
MOQ	TO-251:50/PCS TO-252:2500/PCS

● **Absolute Maximum Ratings** ($T_C = 25^\circ C$)

Parameter	Symbol	Rating	Unit
Drain-Source Voltage	V_{DS}	20	V
Gate-Source Voltage	V_{GS}	± 12	V
Continuous Drain Current	$I_D @ T_C = 25^\circ C$	60	A
	$I_D @ T_C = 75^\circ C$	45	A
	$I_D @ T_C = 100^\circ C$	36	A
Pulsed Drain Current ①	I_{DM}	120	A
Total Power Dissipation	$P_D @ T_C = 25^\circ C$	50	W
Total Power Dissipation	$P_D @ T_A = 25^\circ C$	2.0	W
Operating Junction Temperature	T_J	-55 to 150	$^\circ C$
Storage Temperature	T_{STG}	-55 to 150	$^\circ C$

Note: ① Pulse Test : Pulse width $\leq 300\mu s$, Duty cycle $\leq 2\%$;



Single Pulse Avalanche Energy	E_{AS}	130			mJ	
Avalanche Current	$I_{AS} I_{AR}$	20			A	
•Thermal resistance						
Parameter	Symbol	Min.	Typ.	Max.	Unit	
Thermal resistance, junction - case	R_{thJC}	-	-	2.0	° C/W	
Thermal resistance, junction - ambient	R_{thJA}	-	-	47	° C/W	
Soldering temperature, wave soldering for 8s	T_{sold}	-	-	265	° C	
•Electronic Characteristics						
Parameter	Symbol	Condition	Min.	Typ	Max.	Unit
Drain-Source Breakdown Voltage	BV_{DSS}	$V_{GS} = 0V, I_D = 250\mu A$	20			V
Gate Threshold Voltage	$V_{GS(TH)}$	$V_{GS} = V_{DS}, I_D = 250\mu A$	0.5	0.7	1.0	V
Drain-Source Leakage Current	I_{DSS}	$V_{DS} = 20V, V_{GS} = 0V$			1.0	μA
Gate- Source Leakage Current	I_{GSS}	$V_{GS} = \pm 12V, V_{DS} = 0V$			± 100	nA
Static Drain-source On Resistance	$R_{DS(ON)}$	$V_{GS} = 4.5V, I_D = 20A$		3.2	4.0	m Ω
		$V_{GS} = 2.5V, I_D = 15A$		3.8	5.5	m Ω
Forward Transconductance	g_{FS}	$V_{DS} = 15V, I_D = 10A$		15		S
Source-drain voltage	V_{SD}	$I_S = 20A$			1.20	V
•Electronic Characteristics						
Parameter	Symbol	Condition	Min.	Typ	Max.	Unit
Input capacitance	C_{iss}	$V_{DS} = 15V, V_{GS} = 0V$ $f = 1MHz$	-	1784	-	pF
Output capacitance	C_{oss}		-	266	-	
Reverse transfer capacitance	C_{rss}		-	212	-	
•Gate Charge characteristics ($T_a = 25^\circ C$)						
Parameter	Symbol	Condition	Min.	Typ	Max.	Unit
Gate Resistance	R_g	$f = 1MHz$		1.5		Ω
Total gate charge	Q_g	$V_{DD} = 15V$ $I_D = 20A$ $V_{GS} = 10V$	-	38	-	nC
Gate - Source charge	Q_{gs}		-	5.8	-	
Gate - Drain charge	Q_{gd}		-	7.9	-	
Turn-ON Delay time	$t_{D(on)}$	$V_{GS} = 10V, V_{DS} = 10V$ $R_G = 6.0\Omega, I = 20A$		7		ns
Turn-ON Rise time	t_r			6		ns
Turn-Off Delay time	$t_{D(off)}$			30		ns
Turn-Off Fall time	t_f			8		ns

Fig.1 Power Dissipation

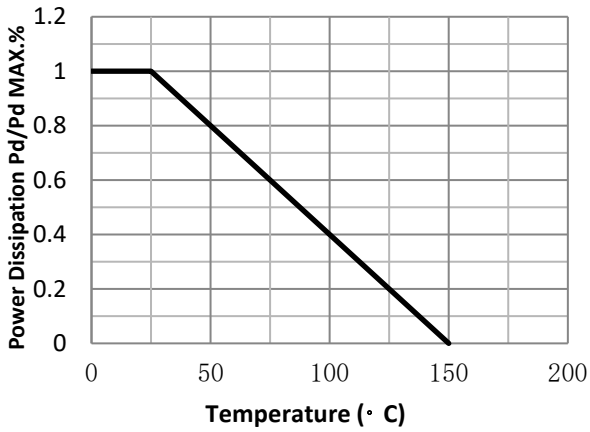

Fig.2 Typical output Characteristics

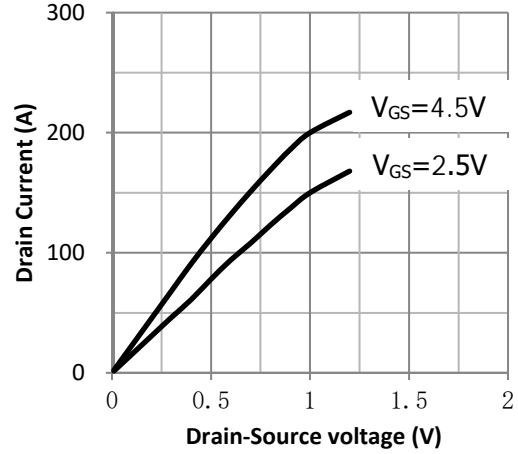

Fig.3 Threshold Voltage V.S Junction Temperature

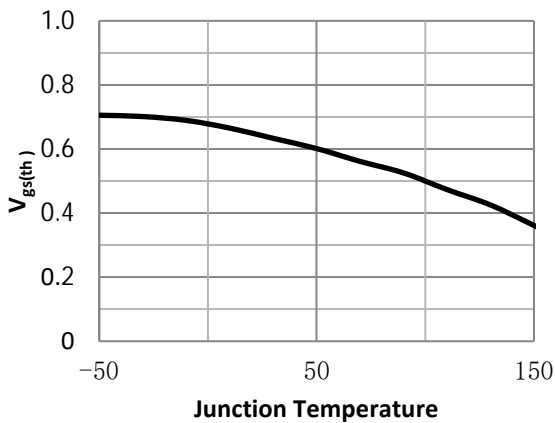

Fig.4 Resistance V.S Drain Current

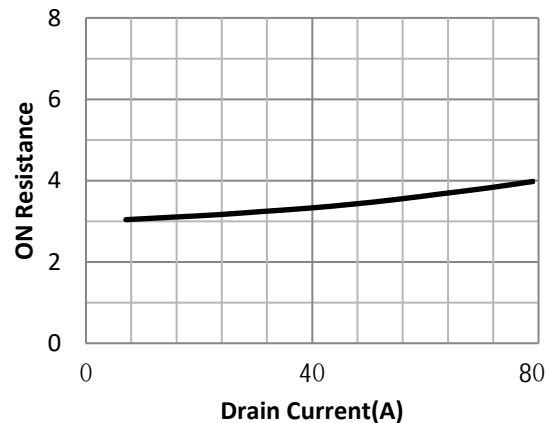

Fig.5 On-Resistance VS Drain Current

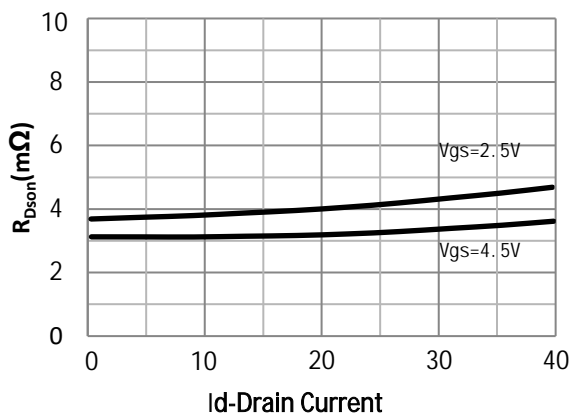

Fig.6 On-Resistance V.S Junction Temperature

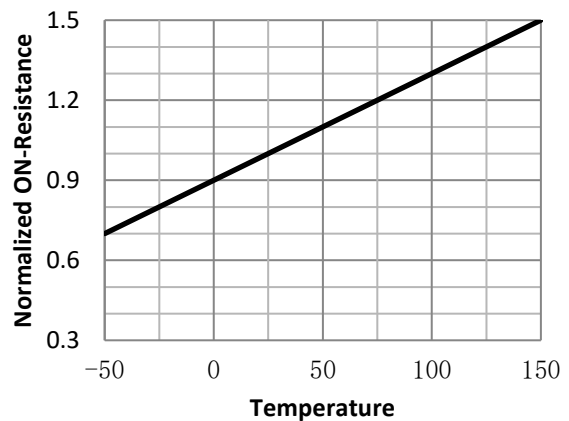

Fig.7 Switching Time Measurement Circuit

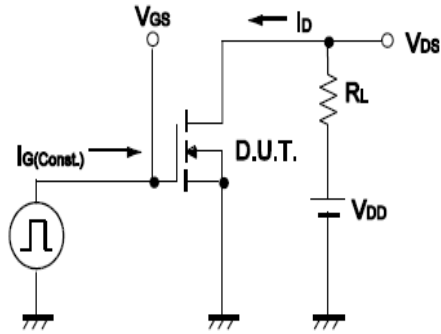

Fig.8 Gate Charge Waveform

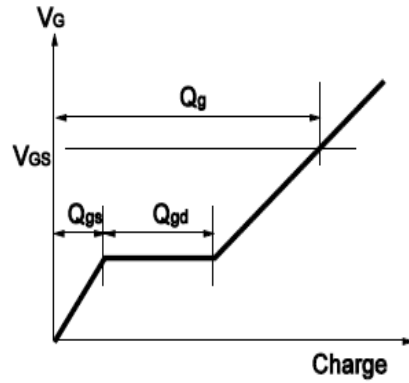

Fig.9 Switching Time Measurement Circuit

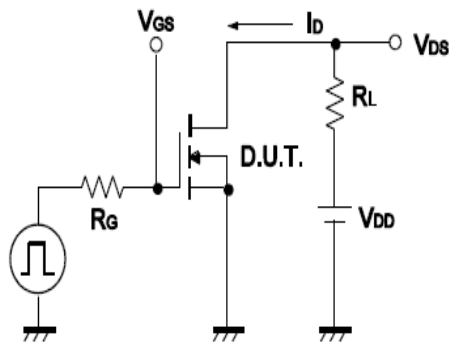

Fig.10 Gate Charge Waveform

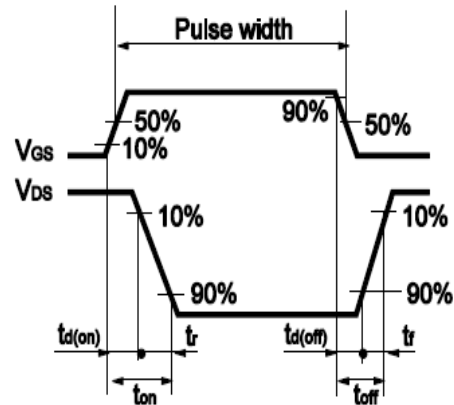

Fig.11 Avalanche Measurement Circuit

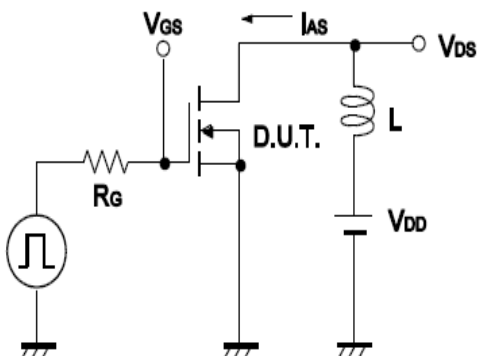
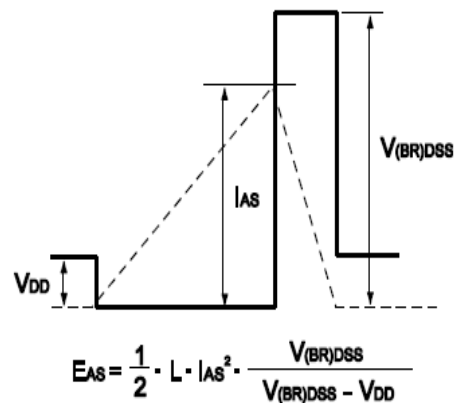
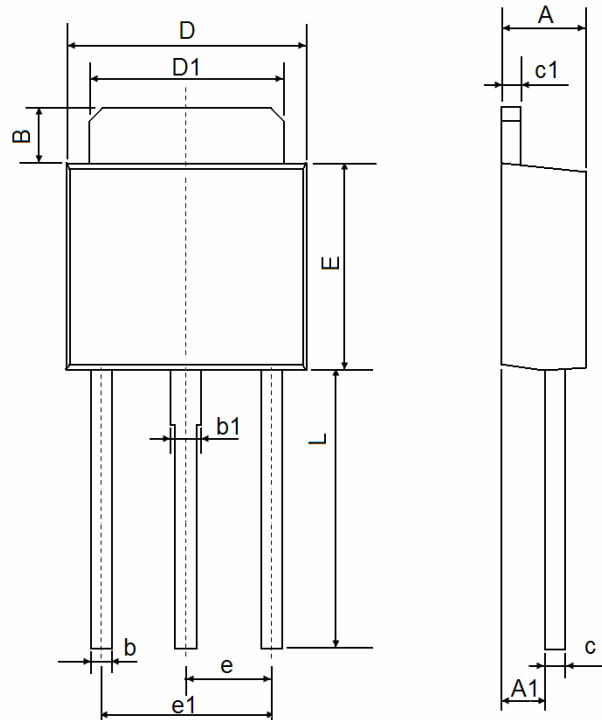

Fig.12 Avalanche Waveform



Package Information

TO-251



Symbol	Dimensions In Millimeters		Dimensions In Inches	
	Min.	Max.	Min.	Max.
A	2.200	2.400	0.087	0.094
A1	1.050	1.350	0.042	0.054
B	0.700	1.000	0.028	0.040
b	0.500	0.700	0.020	0.028
b1	0.700	0.900	0.028	0.035
c	0.430	0.580	0.017	0.023
c1	0.430	0.580	0.017	0.023
D	6.350	6.650	0.250	0.262
D1	5.200	5.400	0.205	0.213
E	5.400	6.000	0.213	0.237
e	2.300 TYP.		0.091 TYP.	
e1	4.500	4.700	0.177	0.185
L	4.900	9.400	0.194	0.372

Notes

1. All dimensions are in millimeters.
2. Tolerance $\pm 0.10\text{mm}$ (4 mil) unless otherwise specified
3. Package body sizes exclude mold flash and gate burrs. Mold flash at the non-lead sides should be less than 5 mils.
4. Dimension L is measured in gauge plane.
5. Controlling dimension is millimeter, converted inch dimensions are not necessarily exact

Package Information

TO-252

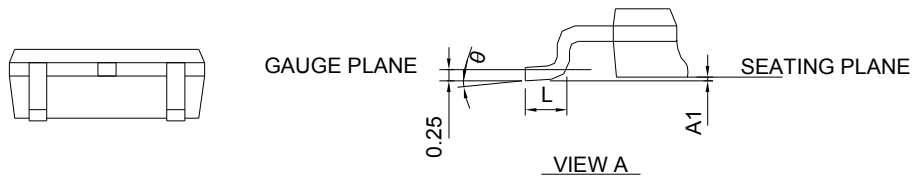
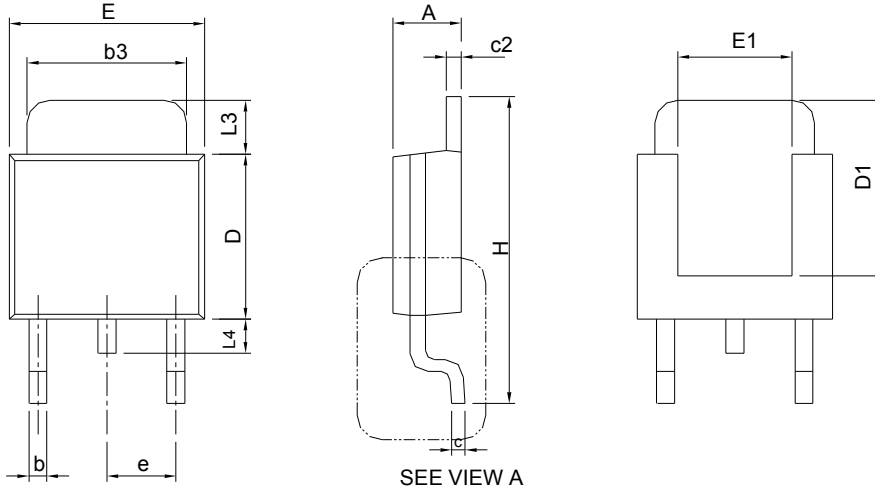

DIMENSIONS	TO-252			
	MILLIMETERS		INCHES	
	MIN.	MAX.	MIN.	MAX.
A	2.18	2.39	0.086	0.094
A1		0.13		0.005
b	0.50	0.89	0.020	0.035
b3	4.95	5.46	0.195	0.215
c	0.46	0.61	0.018	0.024
c2	0.46	0.89	0.018	0.035
D	5.33	6.22	0.210	0.245
D1	4.57	6.00	0.180	0.236
E	6.35	6.73	0.250	0.265
E1	3.81	6.00	0.150	0.236
e	2.29 BSC		0.090 BSC	
H	9.40	10.41	0.370	0.410
L	0.90	1.78	0.035	0.070
L3	0.89	2.03	0.035	0.080
L4		1.02		0.040
θ	0°	8°	0°	8°

RECOMMENDED LAND PATTERN

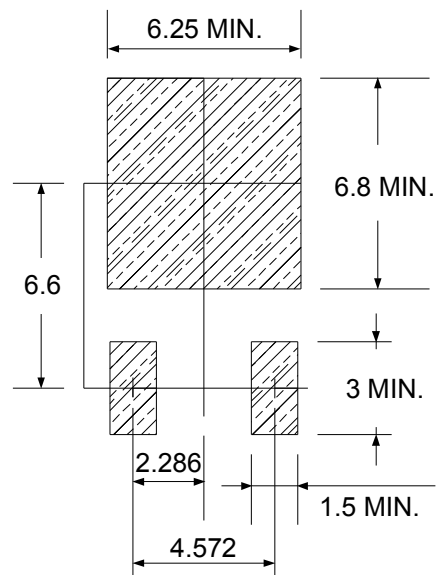

UNIT: mm