

REV	MARK	DESCRIPTION	DRAFTED. BY	DATE

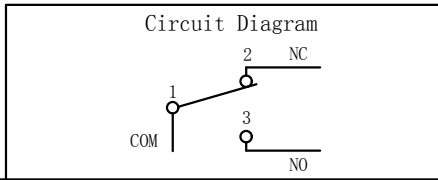
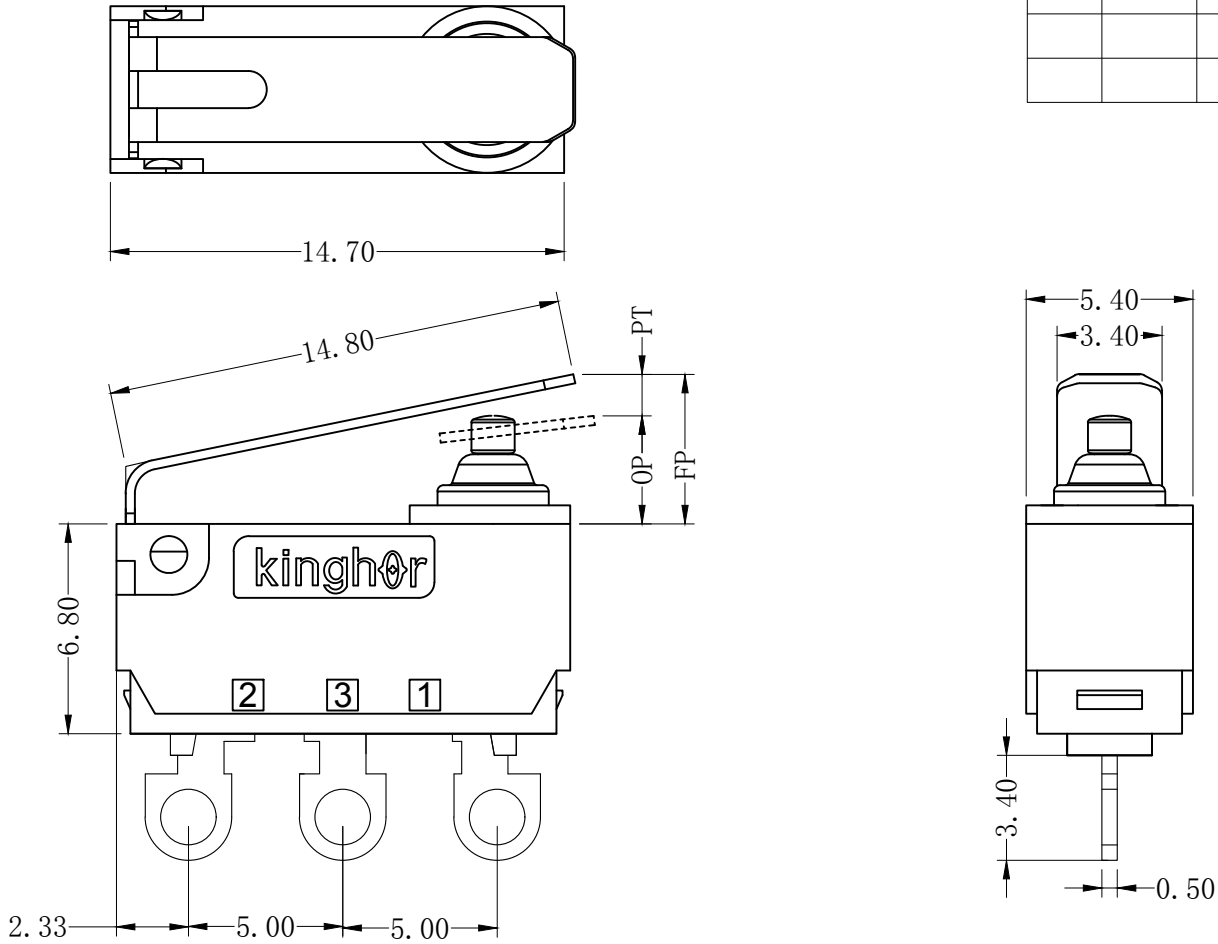

CHARACTERISTICS	
OPERATING FORCE (OF):	195gf Max.
RELEASE FORCE (RF):	25gf Min.
OPERATING POSITION:	3.7 ± 0.6 mm.
PRE TRAVEL:	3.5mm Max.
DIFFERENTIAL TRAVEL:	0.6mm Max.
FREE POSITION:	6.8mm Max.

ELECTRICAL DATA	
RATING	OPERATING LIFE
3A 12VDC	100,000 CYCLES
0.1A 48VDC 125/250VAC	100,000 CYCLES

MECHANICAL LIFE	500,000 CYCLES
GAP TYPE	MICRO
OPERATING TEMP	-40°C ~ +85°C
WATERPROOF	IP67(Except terminal)

OUTLINE DRAWING			
TITLE	H3 SERIES MICRO SWITCH		
MODEL	H3-A1		
PART NO.	H3-A1-1D02B		
DRAFTED BY	Bing Wang	DATE	2020-6-15
CHECKED BY	Hua Bai	DATE	2020-6-15
APPROVED BY	Hong Chen	DATE	2020-6-15

TOLERANCE UNLESS OTHERWISE SPECIFIED							
≤3	1~3	3~10	10~30	30~100	100~200	ANGLE	
±0.2	±0.3	±0.4	±0.6	±1.0	±1.5	±3.0°	
						SCALE	
						UNIT	mm
						VERSION REV	A1

KINGHOR
SWITCHES AND CONTROL EXPERT