

REV	MARK	DESCRIPTION	DRAFTED. BY	DATE

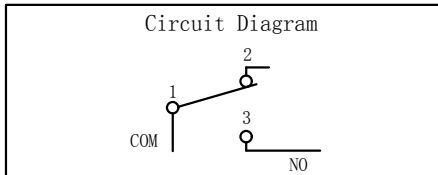
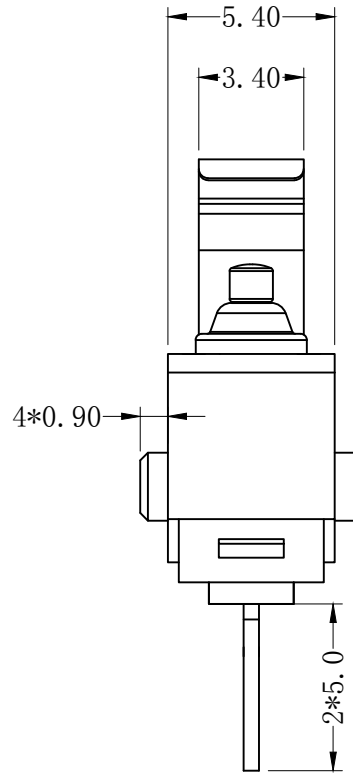
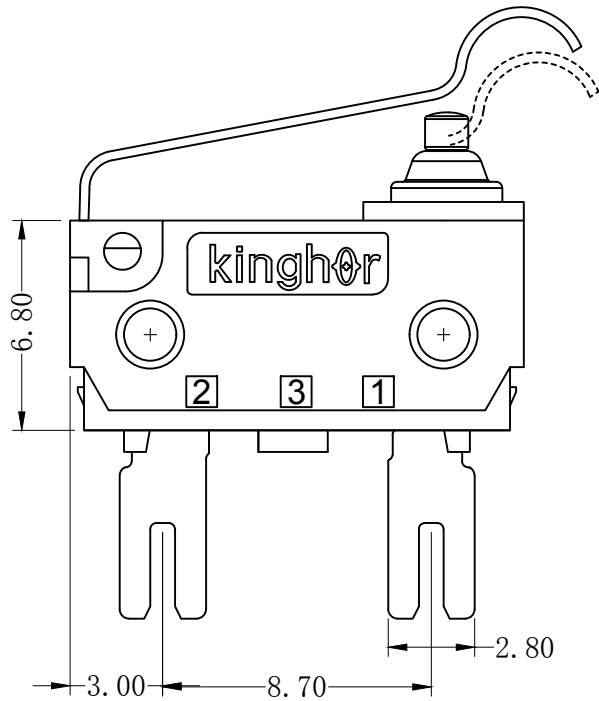
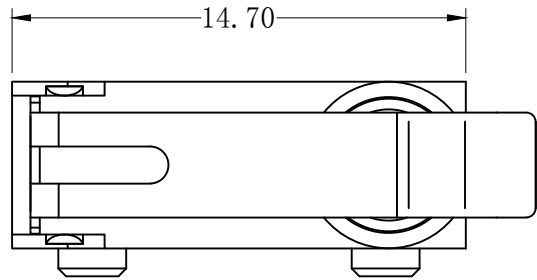

CHARACTERISTICS	
OPERATING FORCE (OF):	180gf Max.
RELEASE FORCE (RF):	15gf Min.
OPERATING POSITION:	9.2 ± 0.7 mm.
PRE TRAVEL:	3.5mm Max.
DIFFERENTIAL TRAVEL:	0.7mm Max.
FREE POSITION:	12.0mm Max.

ELECTRICAL DATA	
<b>RATING</b>	<b>OPERATING LIFE</b>
3A 12VDC	100,000 CYCLES
0.1A 48VDC 125/250VAC	100,000 CYCLES

<b>MECHANICAL LIFE</b>	<b>500,000 CYCLES</b>
<b>GAP TYPE</b>	<b>MICRO</b>
<b>OPERATING TEMP</b>	<b>-40°C ~ +85°C</b>
<b>WATERPROOF</b>	<b>IP67</b>

OUTLINE DRAWING				TOLERANCE UNLESS OTHERWISE SPECIFIED												
<b>TITLE</b>	<b>H3 SERIES MICRO SWITCH</b>			≤3	1~3	3~10	10~30	30~100	100~200	ANGLE						
<b>MODEL</b>	<b>H3-A2</b>			±0.2	±0.3	±0.4	±0.6	±1.0	±1.5	±3.0°						
<b>PART NO.</b>	<b>H3-A2-1C18X5</b>															
<b>DRAFTED BY</b>	Bing Wang	<b>DATE</b>	2020-6-15	<table border="1"> <tr> <td>SCALE</td> <td>mm</td> </tr> <tr> <td>UNIT</td> <td>mm</td> </tr> <tr> <td>VERSION REV</td> <td>A1</td> </tr> </table>							SCALE	mm	UNIT	mm	VERSION REV	A1
SCALE	mm															
UNIT	mm															
VERSION REV	A1															
<b>CHECKED BY</b>	Hua Bai	<b>DATE</b>	2020-6-15	<p style="text-align: center;"><b>KINGHOR</b> SWITCHES AND CONTROL EXPERT</p>												
<b>APPROVED BY</b>	Hong Chen	<b>DATE</b>	2020-6-15													

**KINGHOR**  
SWITCHES AND CONTROL EXPERT