

This IC incorporates a general purpose analog circuit in a small package. This is a CMOS type operational amplifier with phase compensation circuit, which operates at a low voltage and low current consumption.

The S-19610AB is a dual operational amplifier (2 circuits).

Caution This product can be used in vehicle equipment and in-vehicle equipment. Before using the product in the purpose, contact to ABLIC Inc. is indispensable.

■ Features

- Low input offset voltage: $V_{IO} = +6.0$ mV max. ($T_a = -40^{\circ}\text{C}$ to $+125^{\circ}\text{C}$)
- Operation power supply voltage range: $V_{DD} = 2.70$ V to 5.50 V
- Low current consumption (Per circuit): $I_{DD} = 1.00$ mA typ.
- Internal phase compensation: No external parts required
- Operation temperature range: $T_a = -40^{\circ}\text{C}$ to $+125^{\circ}\text{C}$
- Lead-free (Sn 100%), halogen-free
- AEC-Q100 qualified**1

*1. Contact our sales office for details.

■ Applications

- Current sensing
- Signal amplification
- Buffer
- Active filter

■ Package

- TMSOP-8

■ **Block Diagram**

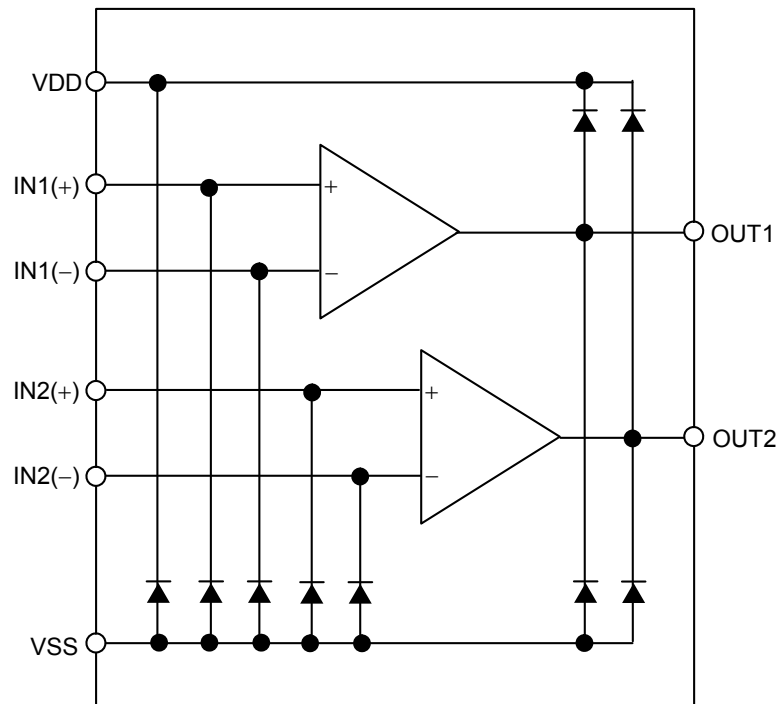

Figure 1

■ **AEC-Q100 Qualified**

This IC supports AEC-Q100 for the operation temperature grade 1.
 Contact our sales office for details of AEC-Q100 reliability specification.

■ **Product Name Structure**

Refer to "1. **Product name**" regarding the contents of product name, "2. **Package**" regarding the package drawings and "3. **Product name list**" regarding the product type.

1. Product name

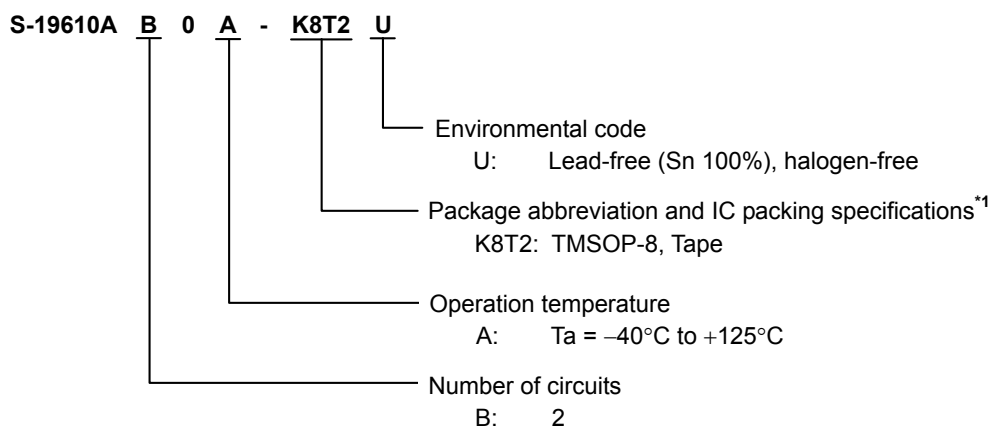

*1. Refer to the tape drawing.

2. Package

Table 1 Package Drawing Codes

Package Name	Dimension	Tape	Reel
TMSOP-8	FM008-A-P-SD	FM008-A-C-SD	FM008-A-R-SD

3. Product name list

Table 2

Product Name	Package
S-19610AB0A-K8T2U	TMSOP-8

■ **Pin Configuration**

1. **TMSOP-8**

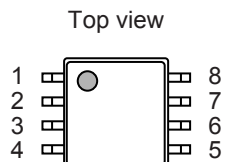

Figure 2

Table 3

Pin No.	Symbol	Description
1	OUT1	Output pin 1
2	IN1(-)	Inverted input pin 1
3	IN1(+)	Non-inverted input pin 1
4	VSS	GND pin
5	IN2(+)	Non-inverted input pin 2
6	IN2(-)	Inverted input pin 2
7	OUT2	Output pin 2
8	VDD	Positive power supply pin

■ Absolute Maximum Ratings

Table 4

(Ta = -40°C to +125°C unless otherwise specified)

Item	Symbol	Absolute Maximum Rating	Unit
Power supply voltage	V _{DD}	V _{SS} - 0.3 to V _{SS} + 7.0	V
Input voltage	V _{IN(+)} , V _{IN(-)}	V _{SS} - 0.3 to V _{SS} + 7.0	V
Output voltage	V _{OUT}	V _{SS} - 0.3 to V _{DD} + 0.3	V
Differential input voltage	V _{IND}	±7.0	V
Output pin current	I _{SOURCE}	20.0	mA
	I _{SINK}	20.0	mA
Operation ambient temperature	T _{opr}	-40 to +125	°C
Storage temperature	T _{stg}	-55 to +150	°C

Caution The absolute maximum ratings are rated values exceeding which the product could suffer physical damage. These values must therefore not be exceeded under any conditions.

■ Thermal Resistance Value

Table 5

Item	Symbol	Condition	Min.	Typ.	Max.	Unit	
Junction-to-ambient thermal resistance*1	θ _{JA}	TMSOP-8	Board A	-	160	-	°C/W
			Board B	-	133	-	°C/W
			Board C	-	-	-	°C/W
			Board D	-	-	-	°C/W
			Board E	-	-	-	°C/W

*1. Test environment: compliance with JEDEC STANDARD JESD51-2A

Remark Refer to "■ Power Dissipation" and "Test Board" for details.

■ **Electrical Characteristics**

1. **Recommended operation condition**

Table 6

(Ta = -40°C to +125°C unless otherwise specified)

Item	Symbol	Condition	Min.	Typ.	Max.	Unit	Test Circuit
Operation power supply voltage range	V _{DD}	-	2.70	5.00	5.50	V	-

2. **V_{DD} = 5.0 V**

Table 7

(Ta = -40°C to +125°C unless otherwise specified)

DC Electrical Characteristics

Item	Symbol	Condition	Min.	Typ.	Max.	Unit	Test Circuit
Current consumption (2 circuits)	I _{DD}	V _{CMR} = V _{OUT} = $\frac{V_{DD}}{2}$, Ta = +25°C	-	2.00	2.50	mA	5
Input offset voltage	V _{IO}	V _{CMR} = $\frac{V_{DD}}{2}$	-6.0	±3.0	+6.0	mV	1
Input offset voltage drift	$\frac{\Delta V_{IO}}{\Delta Ta}$	V _{CMR} = $\frac{V_{DD}}{2}$	-	±3	-	μV/°C	1
Input bias current	I _{BIAS}	Ta = +25°C	-	1	-	pA	-
Input offset current	I _{IO}	Ta = +25°C	-	1	-	pA	-
Common-mode input voltage range	V _{CMR}	Ta = +25°C	-0.1	-	3.8	V	2
Voltage gain (open loop)	A _{VOL}	V _{OUT} = V _{SS} + 0.5 V to V _{DD} - 0.5 V, V _{CMR} = $\frac{V_{DD}}{2}$, R _L = 1.0 MΩ, Ta = +25°C	88	110	-	dB	8
Maximum output swing voltage	V _{OH}	R _L = 1.0 MΩ	4.9	-	-	V	3
	V _{OL}	R _L = 1.0 MΩ	-	-	0.1	V	4
Common-mode input signal rejection ratio	CMRR	V _{CMR} = V _{SS} - 0.1 V to V _{DD} - 1.2 V, Ta = +25°C	70	85	-	dB	2
Power supply voltage rejection ratio	PSRR	2.70 V ≤ V _{DD} ≤ 5.50 V, Ta = +25°C	70	90	-	dB	1
Source current	I _{SOURCE}	V _{OUT} = V _{DD} - 0.12 V, Ta = +25°C	5.0	-	-	mA	6
Sink current	I _{SINK}	V _{OUT} = 0.12 V, Ta = +25°C	5.0	-	-	mA	7

Table 8

(Ta = -40°C to +125°C unless otherwise specified)

AC Electrical Characteristics

Item	Symbol	Condition	Min.	Typ.	Max.	Unit
Slew rate	SR	R _L = 1.0 MΩ, C _L = 15 pF (Refer to Figure 11)	-	2.00	-	V/μs
Gain-bandwidth product	GBP	C _L = 0 pF	-	3.00	-	MHz

■ Test Circuits (Per Circuit)

1. Power supply voltage rejection ratio, input offset voltage

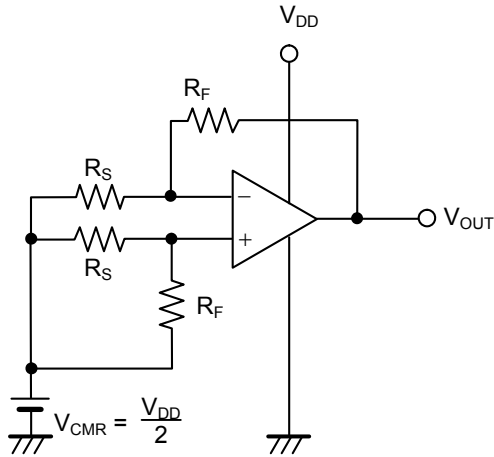

Figure 3 Test Circuit 1

• Power supply voltage rejection ratio (PSRR)

The power supply voltage rejection ratio (PSRR) can be calculated by the following expression, with V_{OUT} measured at each V_{DD} .

Test conditions:

$$V_{DD} = 2.70 \text{ V: } V_{DD} = V_{DD1}, V_{OUT} = V_{OUT1}$$

$$V_{DD} = 5.50 \text{ V: } V_{DD} = V_{DD2}, V_{OUT} = V_{OUT2}$$

$$PSRR = 20 \log \left(\left| \frac{V_{DD1} - V_{DD2}}{\left(V_{OUT1} - \frac{V_{DD1}}{2} \right) - \left(V_{OUT2} - \frac{V_{DD2}}{2} \right)} \right| \times \frac{R_F + R_S}{R_S} \right)$$

• Input offset voltage (V_{IO})

$$V_{IO} = \left(V_{OUT} - \frac{V_{DD}}{2} \right) \times \frac{R_S}{R_F + R_S}$$

2. Common-mode input signal rejection ratio, common-mode input voltage range

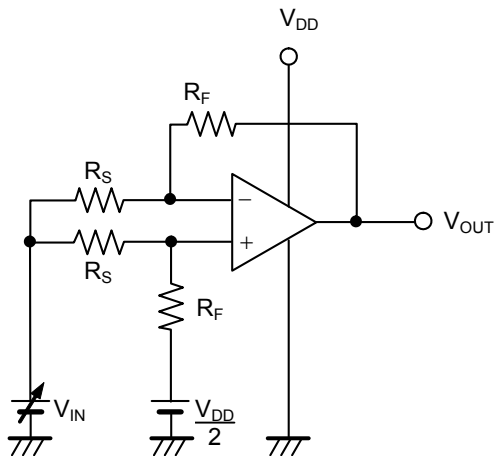

Figure 4 Test Circuit 2

• Common-mode input signal rejection ratio (CMRR)

The common-mode input signal rejection ratio (CMRR) can be calculated by the following expression, with V_{OUT} measured at each V_{IN} .

Test conditions:

$$V_{IN} = V_{CMR \text{ Max.}}: V_{IN} = V_{IN1}, V_{OUT} = V_{OUT1}$$

$$V_{IN} = V_{CMR \text{ Min.}}: V_{IN} = V_{IN2}, V_{OUT} = V_{OUT2}$$

$$CMRR = 20 \log \left(\left| \frac{V_{IN1} - V_{IN2}}{V_{OUT1} - V_{OUT2}} \right| \times \frac{R_F + R_S}{R_S} \right)$$

• Common-mode input voltage range (V_{CMR})

The common-mode input voltage range is the range of V_{IN} in which V_{OUT} satisfies the common-mode input signal rejection ratio specifications when V_{IN} is changed.

3. Maximum output swing voltage (V_{OH})

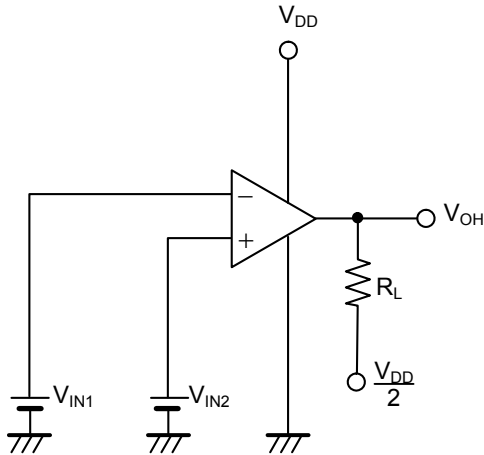

Figure 5 Test Circuit 3

• Maximum output swing voltage (V_{OH})

Test conditions

$$V_{IN1} = \frac{V_{DD}}{2} - 0.1 \text{ V}$$

$$V_{IN2} = \frac{V_{DD}}{2} + 0.1 \text{ V}$$

$$R_L = 1 \text{ M}\Omega$$

4. Maximum output swing voltage (V_{OL})

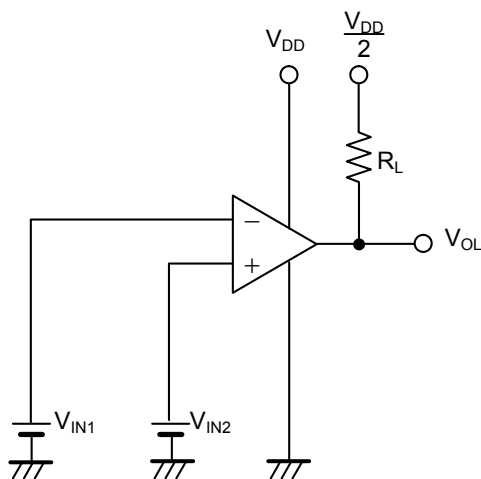

Figure 6 Test Circuit 4

• Maximum output swing voltage (V_{OL})

Test conditions:

$$V_{IN1} = \frac{V_{DD}}{2} + 0.1 \text{ V}$$

$$V_{IN2} = \frac{V_{DD}}{2} - 0.1 \text{ V}$$

$$R_L = 1 \text{ M}\Omega$$

5. Current consumption

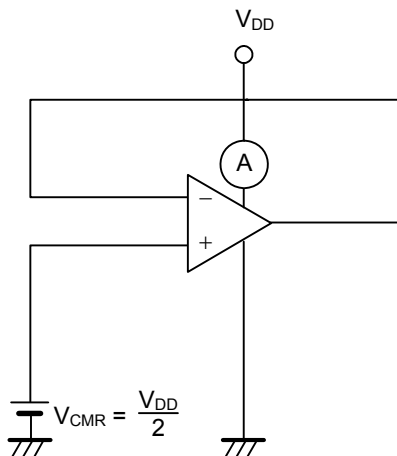

Figure 7 Test Circuit 5

• Current consumption (I_{DD})

6. Source current

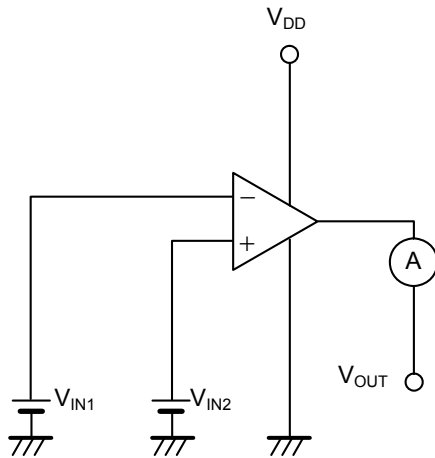

Figure 8 Test Circuit 6

• Source current (I_{SOURCE})

Test conditions:

$$V_{OUT} = V_{DD} - 0.12 \text{ V}$$

$$V_{IN1} = \frac{V_{DD}}{2} - 0.1 \text{ V}$$

$$V_{IN2} = \frac{V_{DD}}{2} + 0.1 \text{ V}$$

7. Sink current

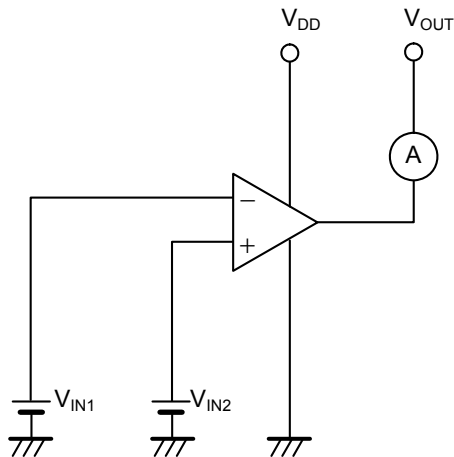

Figure 9 Test Circuit 7

• Sink current (I_{SINK})

Test conditions:

$$V_{OUT} = V_{SS} + 0.12 \text{ V}$$

$$V_{IN1} = \frac{V_{DD}}{2} + 0.1 \text{ V}$$

$$V_{IN2} = \frac{V_{DD}}{2} - 0.1 \text{ V}$$

8. Voltage gain

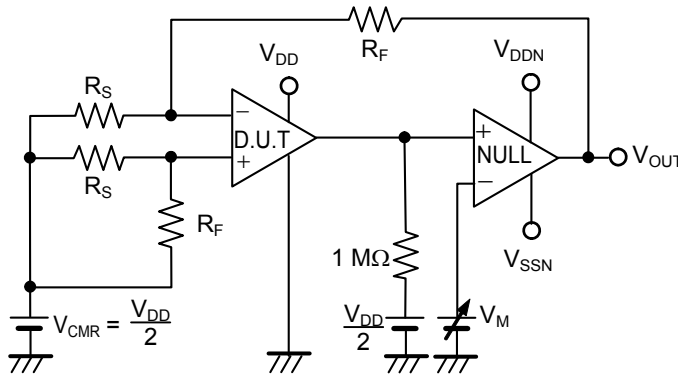

Figure 10 Test Circuit 8

• Voltage gain (open loop) (A_{VOL})

The voltage gain (A_{VOL}) can be calculated by the following expression, with V_{OUT} measured at each V_M .

Test conditions:

$$V_M = V_{DD} - 0.5 \text{ V}: V_M = V_{M1}, V_{OUT} = V_{OUT1}$$

$$V_M = 0.5 \text{ V}: V_M = V_{M2}, V_{OUT} = V_{OUT2}$$

$$A_{VOL} = 20 \log \left(\left| \frac{V_{M1} - V_{M2}}{V_{OUT1} - V_{OUT2}} \right| \times \frac{R_F + R_S}{R_S} \right)$$

9. Slew rate (SR)

Measured by the voltage follower circuit.

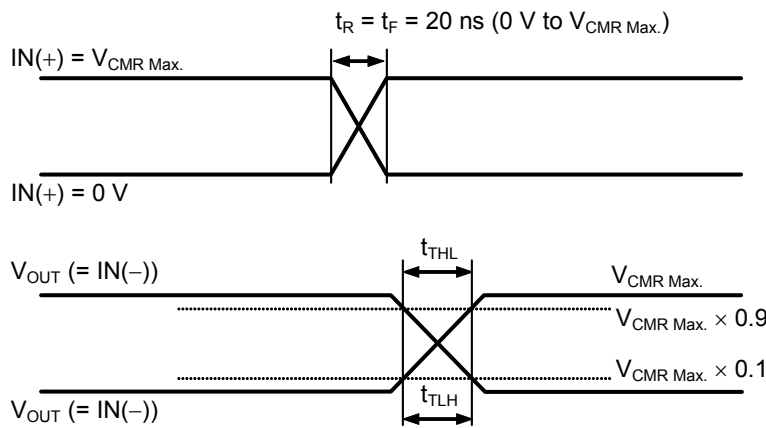

Figure 11

• Slew rate (SR)

$$SR = \frac{V_{CM \text{ Max.}} \times 0.8}{t_{TLH}}$$

$$SR = \frac{V_{CM \text{ Max.}} \times 0.8}{t_{TLH}}$$

■ Precautions

- Do not apply an electrostatic discharge to this IC that exceeds performance ratings of the built-in electrostatic protection circuit.
- ABLIC Inc. claims no responsibility for any disputes arising out of or in connection with any infringement by products including this IC of patents owned by a third party.
- Use this IC with the output current of 20 mA or less.
- This IC operates stably even directly connecting a load capacitance of 100 pF or less to the output pin, as shown in **Figure 12**. When connecting a load capacitance of 100 pF or more, connect a resistor of 47 Ω or more as shown in **Figure 13**. In case of connecting a filter for noise prevention, and connecting a load capacitance of 100 pF or more, also connect a resistor of 47 Ω or more as shown in **Figure 14**.

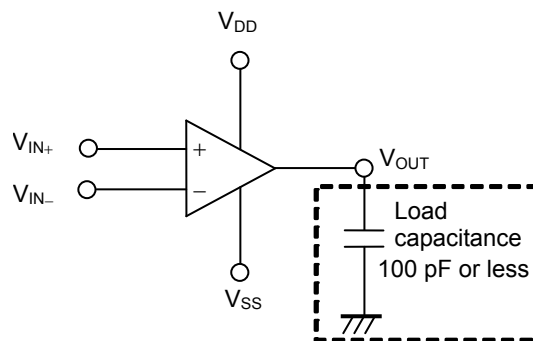

Figure 12

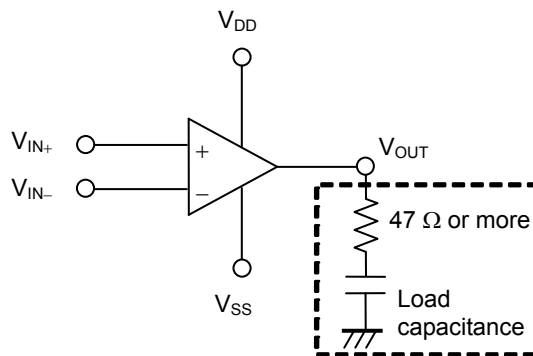

Figure 13

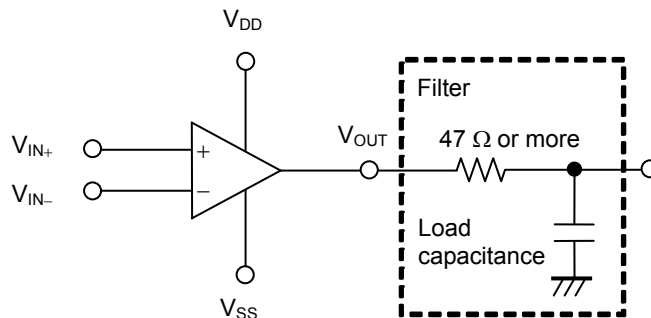
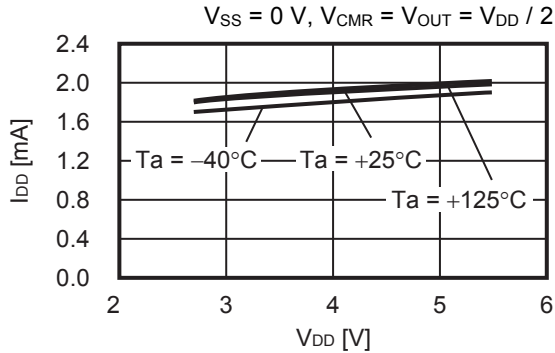

Figure 14

Caution The above connection diagrams and constants will not guarantee successful operation. Perform thorough evaluation using the actual application to set the constants.

■ **Characteristics (Typical Data)**

1. Current consumption (I_{DD}) (2 circuits) vs. Power supply voltage (V_{DD})



2. Voltage gain (A_{VOL}) vs. Frequency (f)

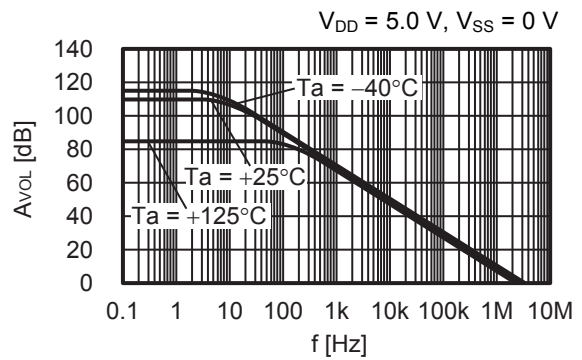
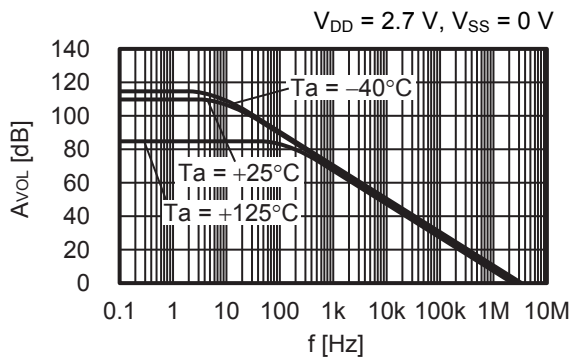

3. Output current

3.1 Source current (I_{SOURCE}) vs. Power supply voltage (V_{DD})

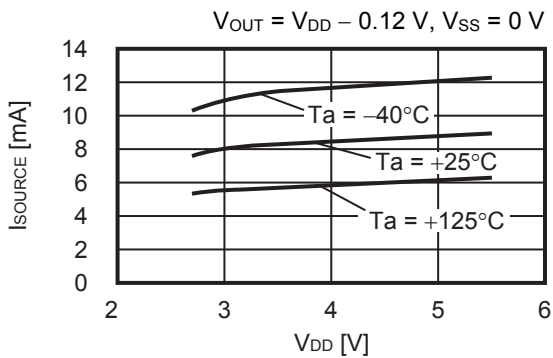

3.2 Sink current (I_{SINK}) vs. Power supply voltage (V_{DD})

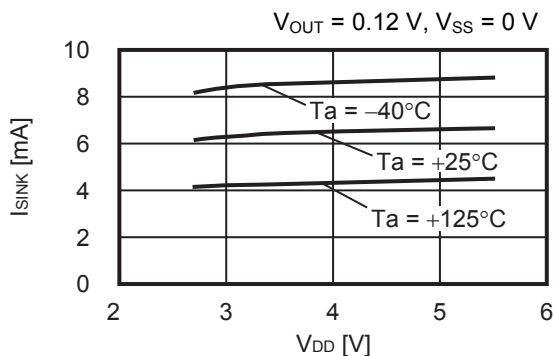

3.3 Output voltage (V_{OUT}) vs. Source current (I_{SOURCE})

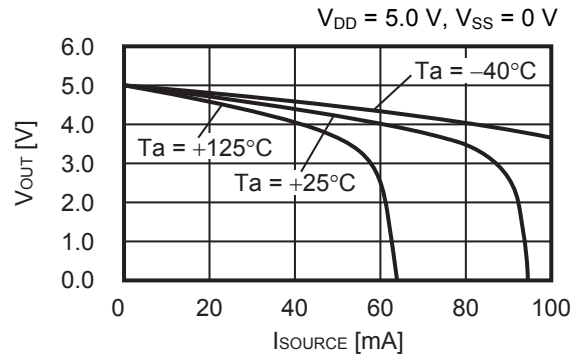
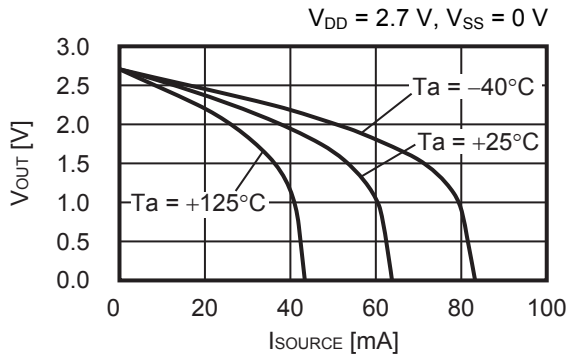

3.4 Output voltage (V_{OUT}) vs. Sink current (I_{SINK})

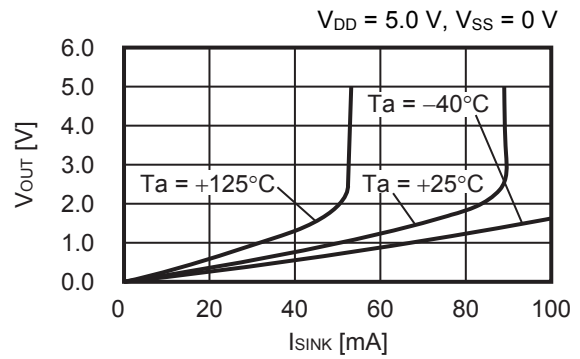
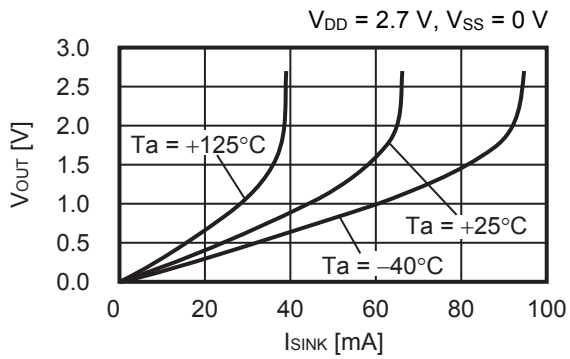

4. Input bias current (I_{BIAS}) vs. Temperature (T_a)

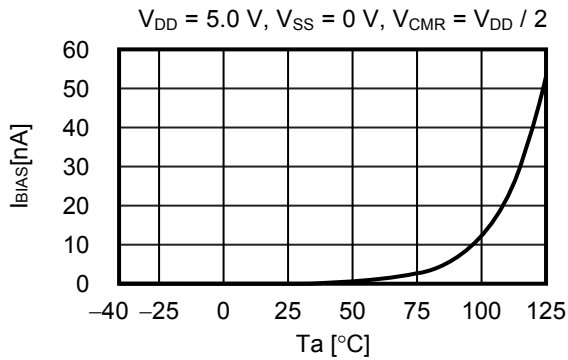

■ **Power Dissipation**

TMSOP-8

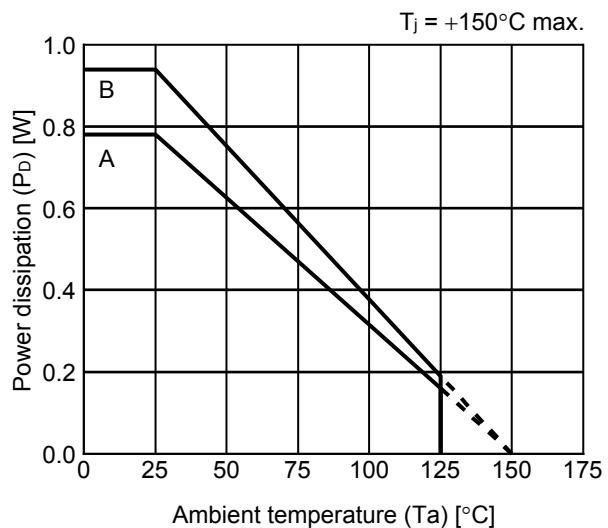

Board	Power Dissipation (P_D)
A	0.78 W
B	0.94 W
C	–
D	–
E	–

TMSOP-8 Test Board

(1) Board A

 IC Mount Area

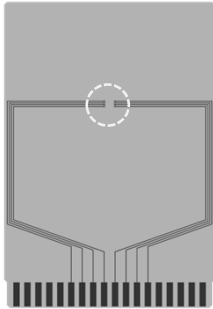

Item	Specification	
Size [mm]	114.3 x 76.2 x t1.6	
Material	FR-4	
Number of copper foil layer	2	
Copper foil layer [mm]	1	Land pattern and wiring for testing: t0.070
	2	-
	3	-
	4	74.2 x 74.2 x t0.070
Thermal via	-	

(2) Board B

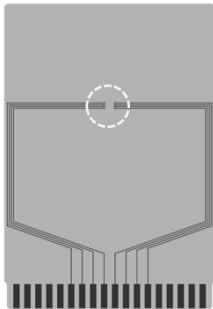

Item	Specification	
Size [mm]	114.3 x 76.2 x t1.6	
Material	FR-4	
Number of copper foil layer	4	
Copper foil layer [mm]	1	Land pattern and wiring for testing: t0.070
	2	74.2 x 74.2 x t0.035
	3	74.2 x 74.2 x t0.035
	4	74.2 x 74.2 x t0.070
Thermal via	-	

No. TMSOP8-A-Board-SD-1.0

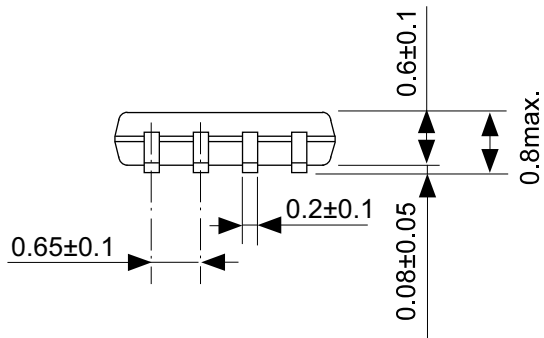
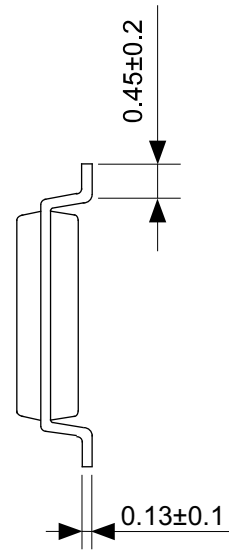
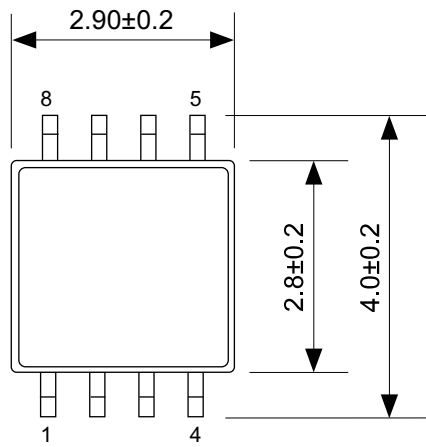

No. FM008-A-P-SD-1.2

TITLE	TMSOP8-A-PKG Dimensions
No.	FM008-A-P-SD-1.2
ANGLE	
UNIT	mm
ABLIC Inc.	

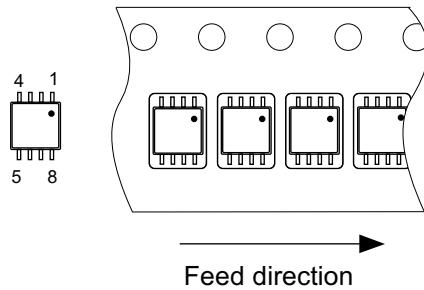
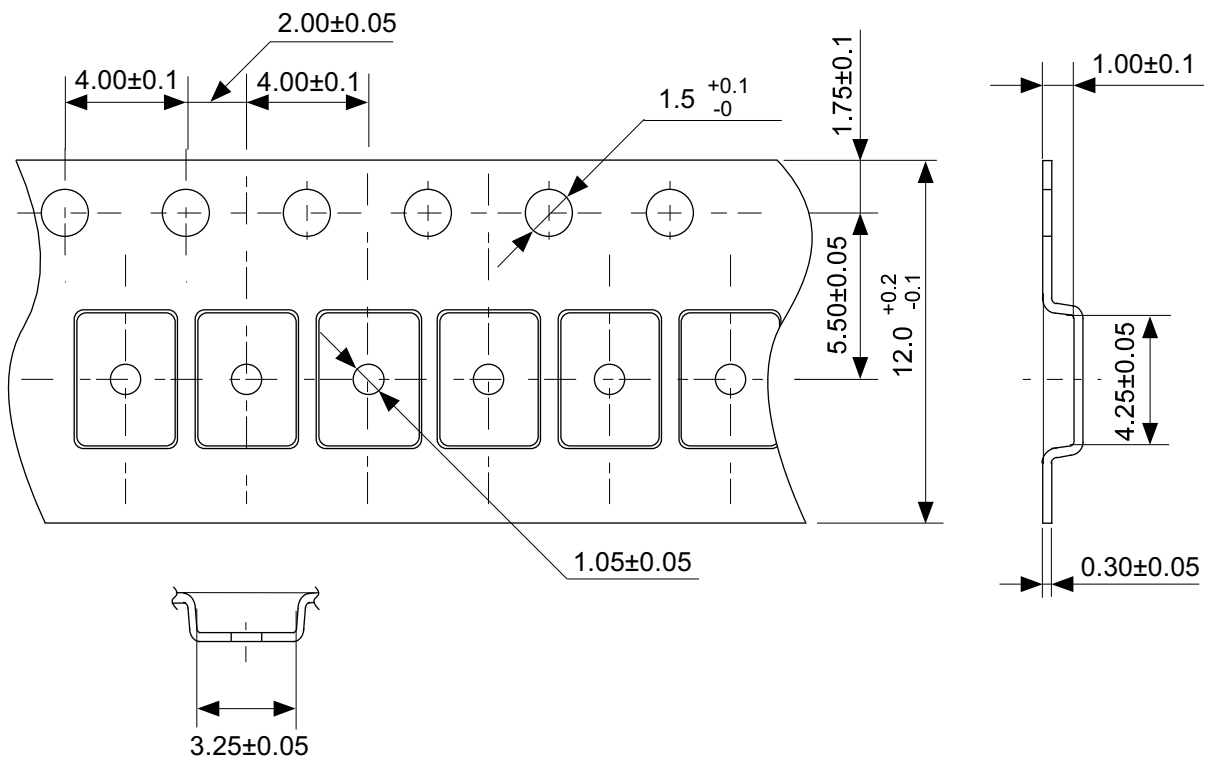

No. FM008-A-C-SD-2.0

TITLE	TMSOP8-A-Carrier Tape
No.	FM008-A-C-SD-2.0
ANGLE	
UNIT	mm
ABLIC Inc.	

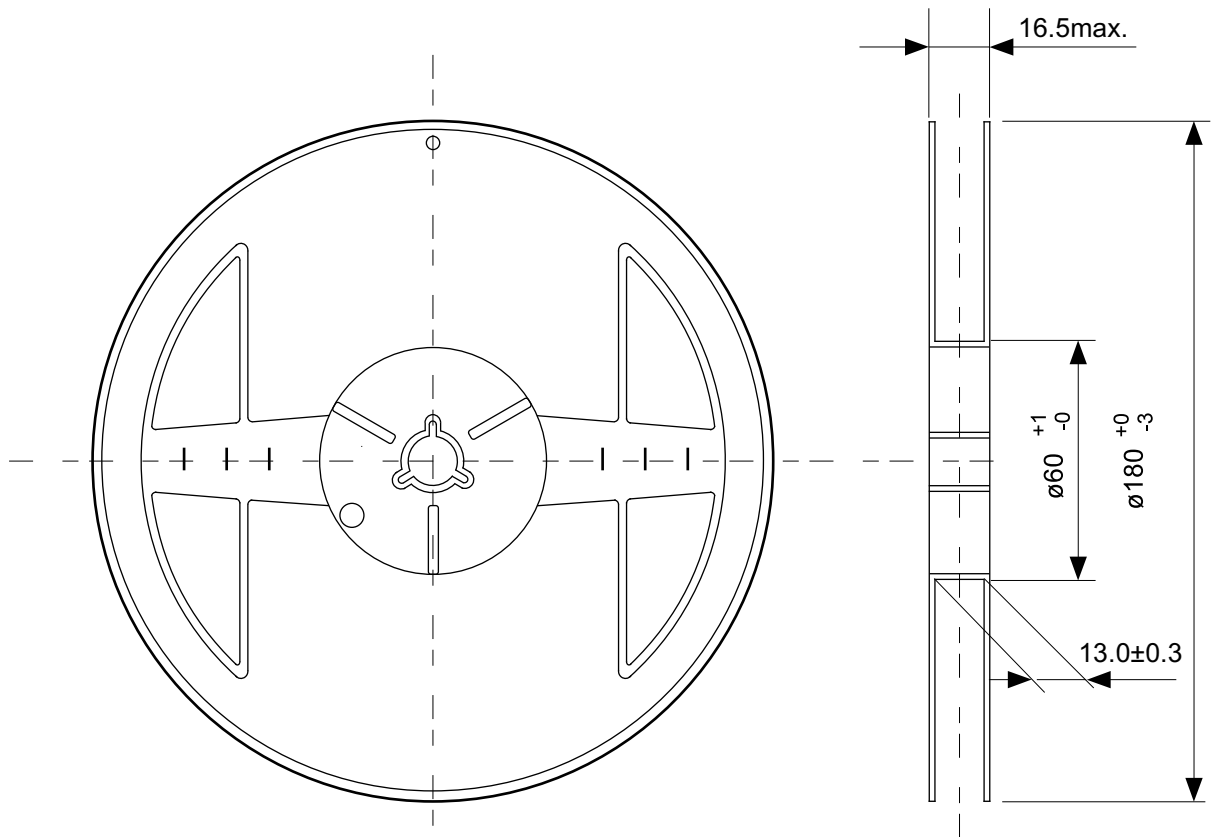

Enlarged drawing in the central part

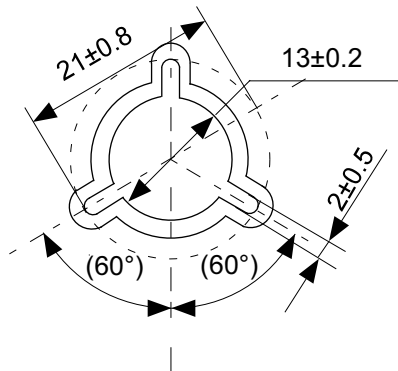

No. FM008-A-R-SD-1.0

TITLE	TMSOP8-A-Reel		
No.	FM008-A-R-SD-1.0		
ANGLE		QTY.	4,000
UNIT	mm		
ABLIC Inc.			

Disclaimers (Handling Precautions)

1. All the information described herein (product data, specifications, figures, tables, programs, algorithms and application circuit examples, etc.) is current as of publishing date of this document and is subject to change without notice.
2. The circuit examples and the usages described herein are for reference only, and do not guarantee the success of any specific mass-production design.
ABLIC Inc. is not liable for any losses, damages, claims or demands caused by the reasons other than the products described herein (hereinafter "the products") or infringement of third-party intellectual property right and any other right due to the use of the information described herein.
3. ABLIC Inc. is not liable for any losses, damages, claims or demands caused by the incorrect information described herein.
4. Be careful to use the products within their ranges described herein. Pay special attention for use to the absolute maximum ratings, operation voltage range and electrical characteristics, etc.
ABLIC Inc. is not liable for any losses, damages, claims or demands caused by failures and / or accidents, etc. due to the use of the products outside their specified ranges.
5. Before using the products, confirm their applications, and the laws and regulations of the region or country where they are used and verify suitability, safety and other factors for the intended use.
6. When exporting the products, comply with the Foreign Exchange and Foreign Trade Act and all other export-related laws, and follow the required procedures.
7. The products are strictly prohibited from using, providing or exporting for the purposes of the development of weapons of mass destruction or military use. ABLIC Inc. is not liable for any losses, damages, claims or demands caused by any provision or export to the person or entity who intends to develop, manufacture, use or store nuclear, biological or chemical weapons or missiles, or use any other military purposes.
8. The products are not designed to be used as part of any device or equipment that may affect the human body, human life, or assets (such as medical equipment, disaster prevention systems, security systems, combustion control systems, infrastructure control systems, vehicle equipment, traffic systems, in-vehicle equipment, aviation equipment, aerospace equipment, and nuclear-related equipment), excluding when specified for in-vehicle use or other uses by ABLIC, Inc. Do not apply the products to the above listed devices and equipments.
ABLIC Inc. is not liable for any losses, damages, claims or demands caused by unauthorized or unspecified use of the products.
9. In general, semiconductor products may fail or malfunction with some probability. The user of the products should therefore take responsibility to give thorough consideration to safety design including redundancy, fire spread prevention measures, and malfunction prevention to prevent accidents causing injury or death, fires and social damage, etc. that may ensue from the products' failure or malfunction.
The entire system in which the products are used must be sufficiently evaluated and judged whether the products are allowed to apply for the system on customer's own responsibility.
10. The products are not designed to be radiation-proof. The necessary radiation measures should be taken in the product design by the customer depending on the intended use.
11. The products do not affect human health under normal use. However, they contain chemical substances and heavy metals and should therefore not be put in the mouth. The fracture surfaces of wafers and chips may be sharp. Be careful when handling these with the bare hands to prevent injuries, etc.
12. When disposing of the products, comply with the laws and ordinances of the country or region where they are used.
13. The information described herein contains copyright information and know-how of ABLIC Inc. The information described herein does not convey any license under any intellectual property rights or any other rights belonging to ABLIC Inc. or a third party. Reproduction or copying of the information from this document or any part of this document described herein for the purpose of disclosing it to a third-party is strictly prohibited without the express permission of ABLIC Inc.
14. For more details on the information described herein or any other questions, please contact ABLIC Inc.'s sales representative.
15. This Disclaimers have been delivered in a text using the Japanese language, which text, despite any translations into the English language and the Chinese language, shall be controlling.

2.4-2019.07