



苏州敏芯微电子技术股份有限公司
MEMSensing Microsystems (Suzhou, China) Co., Ltd.

Data Sheet

V 1.1 / Oct. 2017

MSM261S4030H0R

I²S digital output MEMS microphone with Multi-modes

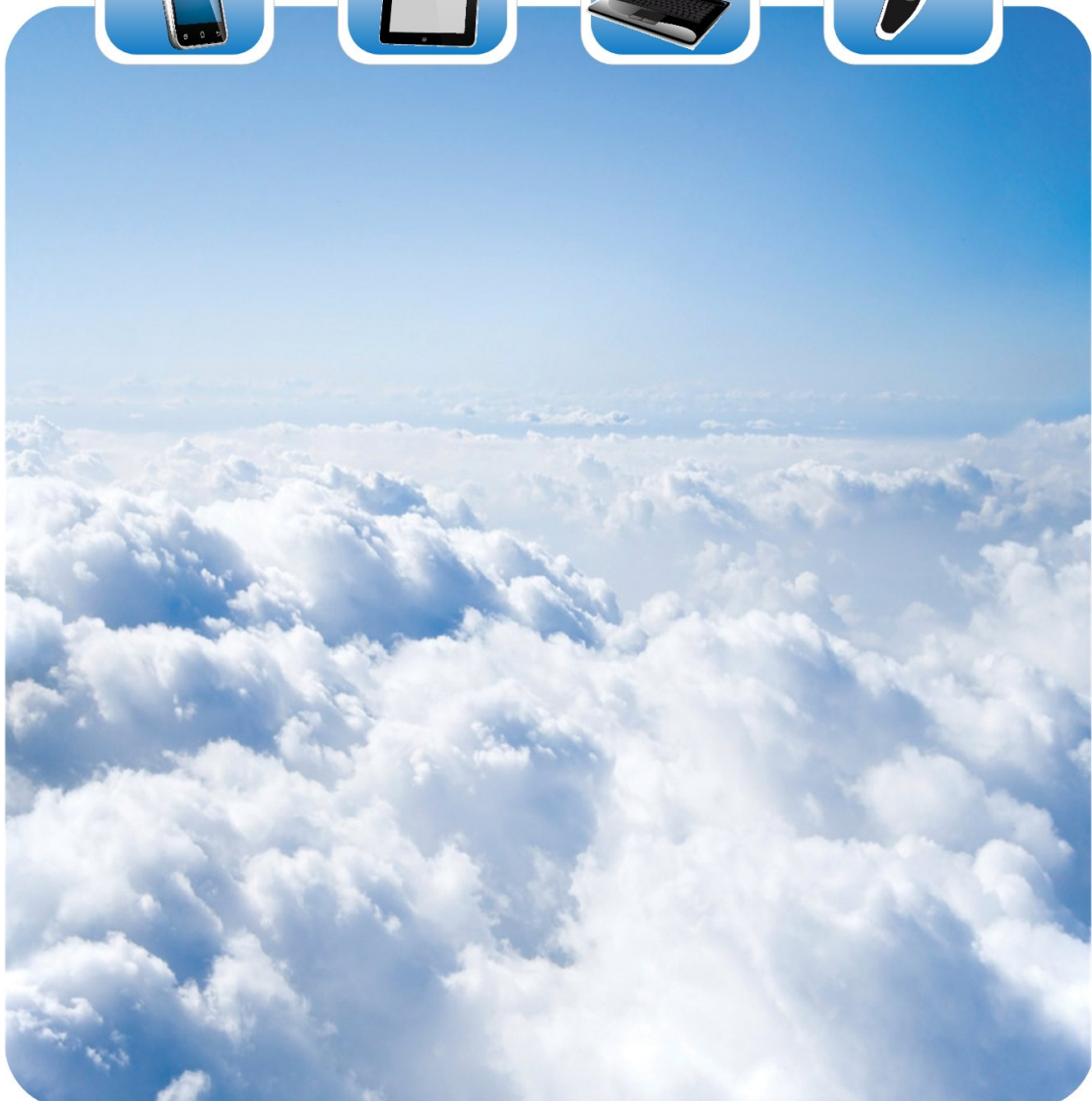

MSM261S4030H0R

I²S digital output MEMS microphone



苏州敏芯微电子技术股份有限公司
MEMSensing Microsystems (Suzhou, China) Co., Ltd.



GENERAL DESCRIPTION

MSM261S4030H0R is an omnidirectional, Top-ported, I²S digital output MEMS microphone. It has high performance and reliability.

MSM261S4030H0R is available in a 4 mm × 3 mm × 1.0 mm metal can LGA package. It is SMT compatible with no sensitivity degradation.

APPLICATIONS

- ✧ Mobile Phone
- ✧ Laptop
- ✧ Tablet computer
- ✧ Bluetooth headset
- ✧ Earphone
- ✧ Wearable intelligent equipment

FEATURES

- ✧ Cost effective
- ✧ Low Power mode
- ✧ Digital I²S output
- ✧ Compatible with Sn/Pb and Pb-free solder processes
- ✧ RoHS/Halogen free compliant
- ✧ Sensitivity Matching within +/-1dB

PRODUCT VIEW

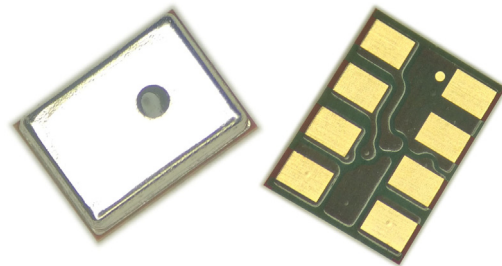



ABSOLUTE MAXIMUM RATINGS

Parameter	Maximum value	Unit
Supply Voltage	-0.3 to 4.0	V
Sound Pressure Level	140	dB SPL
Mechanical Shock	10,000	g
Temperature Range	-40 to 100	°C
Electrostatic discharge protection	2 (HBM)	kV

SPECIFICATIONS

All data taken at 25°C, Relative Humidity 45±5% L/R pin grounded unless otherwise specified
Vdd=1.8V, clock frequency=3.072MHz

	Limits			unit	condition
	Min.	Nom.	Max.		
Directivity	Omni directional				
Sensitivity	-27	-26	-25	dB	dBFS @1kHz 1Pa
Operation voltage	1.6		3.6	V	
Freq. range	Refer to the frequency response			Hz	
Sensitivity loss across supply voltage	No change across the voltage range			dB	
Signal to noise ratio	-	61	-	dB	20 kHz bandwidth, A-weighted
THD	-	0.2	-	%	94dB SPL @1kHz S =Nom, Rload > 2 k
AOP	-	124	-	dB SPL	10% THD @1kHz S =Nom, Rload > 2 k
Polarity	Increasing sound				Increasing density of 1's
PSR		-72		dBFS(A)	
Current consumption	-	750	1000	μA	Normal mode
	-	400	-	μA	Low power mode
Clock frequency	1.0	3	4.0	MHz	Normal mode
	150	-	800	KHz	Low power mode
Storage temperature	-40	-	100	°C	



TYPICAL FREQUENCY RESPONSE

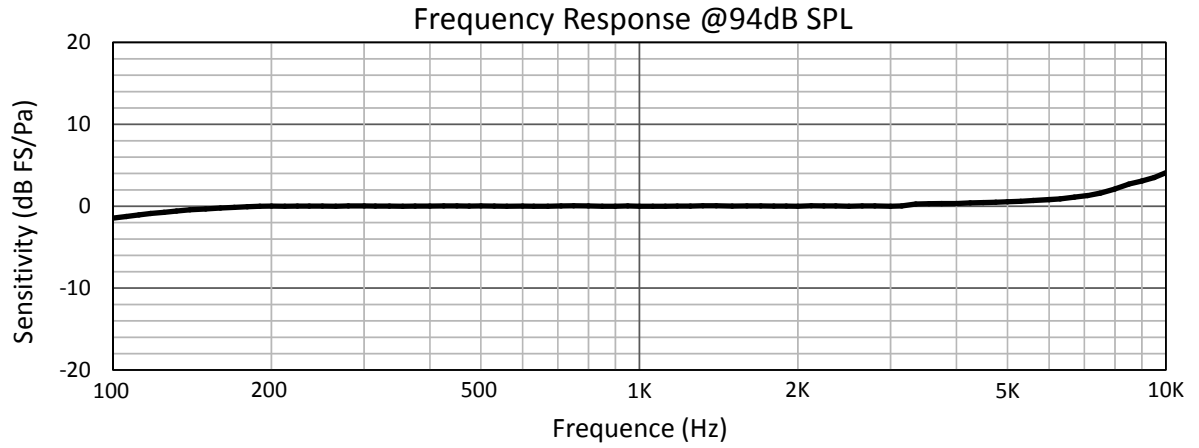

LOGIC TABLE

	Parameter	Symbol	Min	Max	Unit
Digital Input	Low Voltage Input(L/R, WS, SCK)	VIL	0	$0.25 \times VDD$	V
	High Voltage Input(L/R, WS, SCK)	VIH	$0.7 \times VDD$	VDD	V
SD	Voltage Output Low	VOL		$0.1 \times VDD$	V
	Voltage Output Low	VOL		$0.3 \times VDD$	V
Digital Output	Voltage Output High	VOH	$0.7 \times VDD$		V
	Voltage Output High	VOH	$0.9 \times VDD$		V
Output	Voltage Output Low	VOL		$0.1 \times VDD$	V
	Voltage Output Low	VOL		$0.3 \times VDD$	V
	Voltage Output High	VOH	$0.7 \times VDD$		V
	Voltage Output High	VOH	$0.9 \times VDD$		V



TIMING DIAGRAM

Parameter	Description	Min.	Norm.	Max.	Unit
tSCH	SCK High	—	50	—	ns
tSCL	SCK Low	—	50	—	ns
tSCP	SCK Period	—	325	—	ns
fSCK	SCK Frequency	—	3.072	—	MHz
tWSS	WS Setup	—	0	—	ns
tWSH	WS Hold	—	20	—	ns
fWS	WS Frequency	—	48	—	kHz

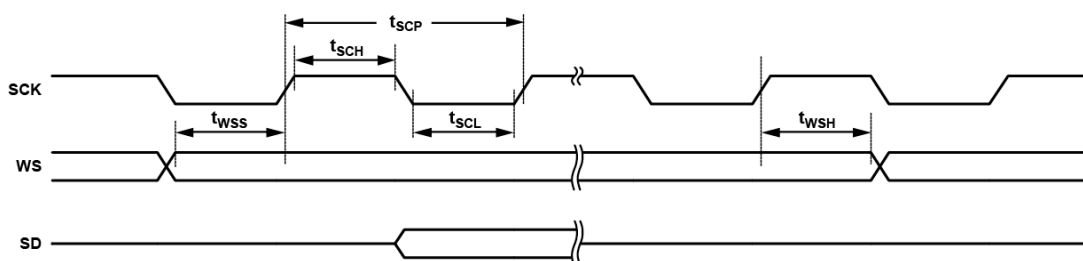

SMT Parameters:

1. Recommend PCB land pattern layout: (unit: mm)

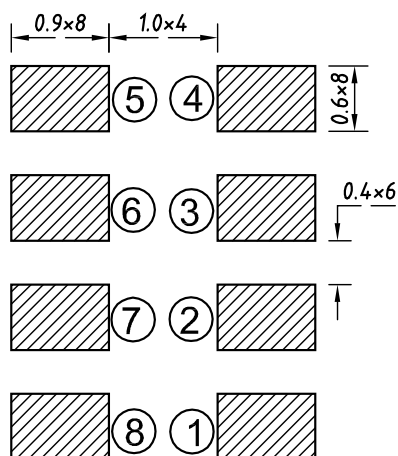



2. Recommend reflow profile:

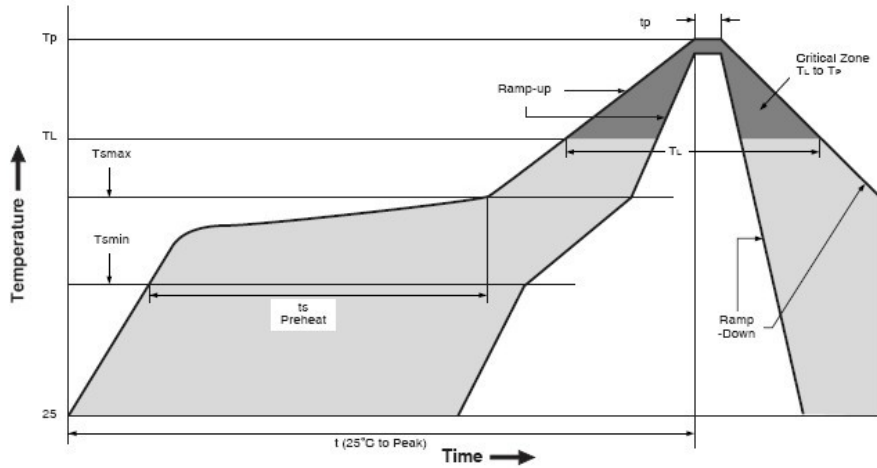

Description	Parameter	Pb free
Average ramp rate	T_L to T_P	3 °C/sec max
Preheat		
Minimum temperature	T_{SMIN}	150 °C
Maximum temperature	T_{SMAX}	200 °C
Time(T_{SMIN} to T_{SMAX})	t_S	60 sec to 120 sec
Ramp-up rate	T_{SMAX} to T_L	1.25 °C/sec
Time maintained above liquidus temperature	t_L	60 sec to 150 sec
Liquidus temperature	T_L	217 °C
Peak temperature	T_P	260 °C
Time within 5°C of actual peak temperature	t_p	20 sec to 40 sec
Ramp-down rate	T_P to T_{smax}	6 °C/sec max
Time 25 °C ($t_{25 °C}$) to peak temperature	t	8 minutes max



OUTLINE DIMENSIONS AND PIN DEFINITION:

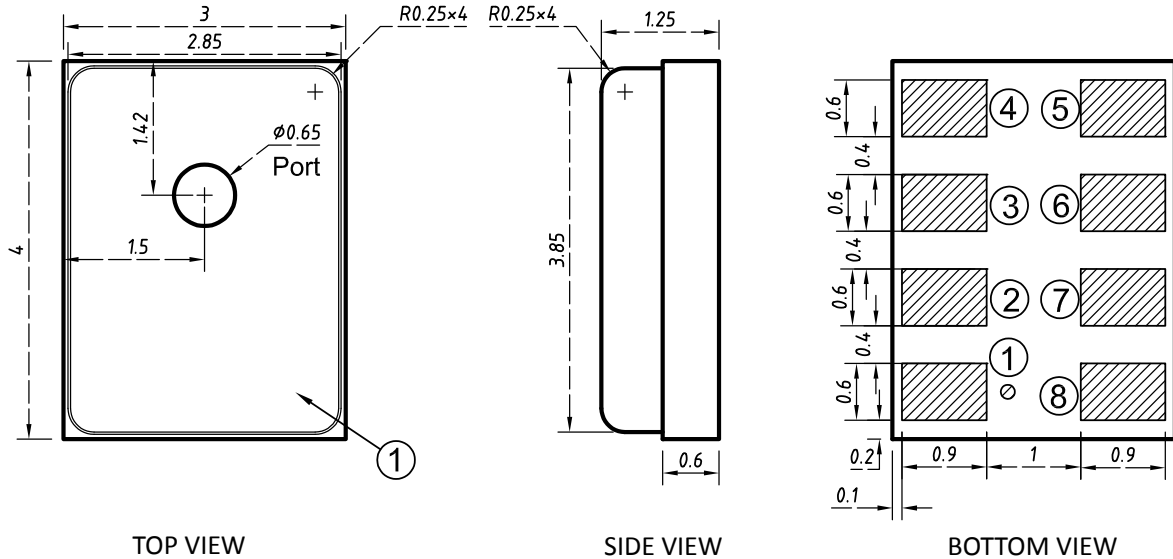
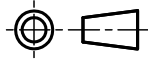

TOP VIEW

SIDE VIEW

BOTTOM VIEW

1	GND	Ground	Connect to ground on the PCB.
2	N/C	—	Do not connect
3	WS	Input	Serial Data-Word Select for I ² S Interface.
4	CHIPEN	Input	Microphone Enable. When set low (ground), the microphone is disabled and put in power-down mode. When set high (VDD), the microphone is enabled.
5	L/R	Input	Left/Right Channel Select. When set low, the microphone outputs its signal in the left channel of the I ² S frame; when set high, the microphone outputs its signal in the right channel.
6	SCK	Input	Serial Data Clock for I ² S Interface.
7	SD	Output	Serial Data Output for I ² S Interface. This pin tristates when not actively driving the appropriate output channel. The SD trace should have a 100 kΩ pull-down resistor to discharge the line during the time that all microphones on the bus have tristated their outputs.
8	VDD	Power	1.8 to 3.3 V. This pin should be decoupled to Pin 1 with a 0.1 μF capacitor and a 10μF capacitor.

Item	Dimension	Tolerance
Length (L)	4.0	±0.10
Width (W)	3.0	±0.10
Height (H)	1.25	±0.10
Acoustic Port (AP)	∅0.65	±0.05

Dimensions are in millimeters
Tolerance is ±0.1mm unless otherwise specified.

MSM261S4030HOR

I²S digital output MEMS microphone



苏州敏芯微电子技术股份有限公司
MEMSensing Microsystems (Suzhou, China) Co., Ltd.



ADDITIONAL NOTES

- (A) MSL (moisture sensitivity level) Class 2a.
- (B) Maximum of 3 reflow cycles is recommended.
- (C) In order to minimize device damage:
 - Do not board wash or clean after the reflow process.
 - Do not brush board with or without solvents after the reflow process.
 - Do not directly expose to ultrasonic processing, welding, or cleaning.
 - Do not insert any object in port hole of device at any time.
 - Do not apply air pressure into the port hole.
 - Do not pull a vacuum over port hole of the microphone.

MATERIALS STATEMENT

Meets the requirements of the European RoHS and Halogen-Free.



PACKAGING & MARKING DETAIL:

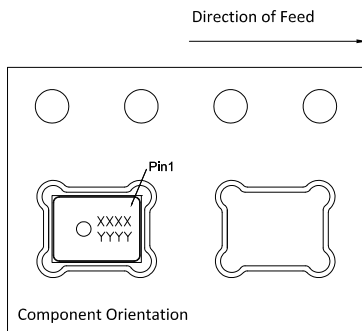
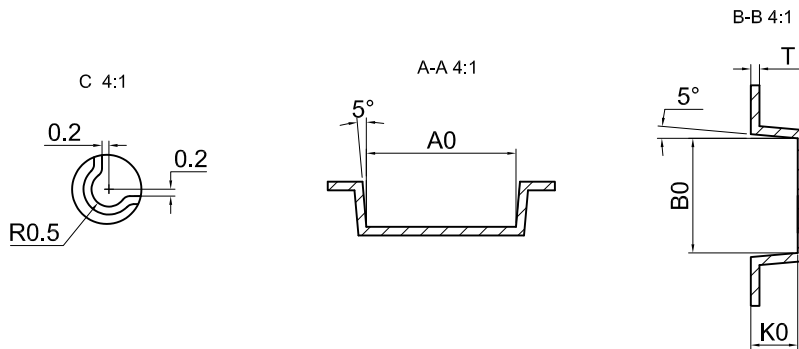
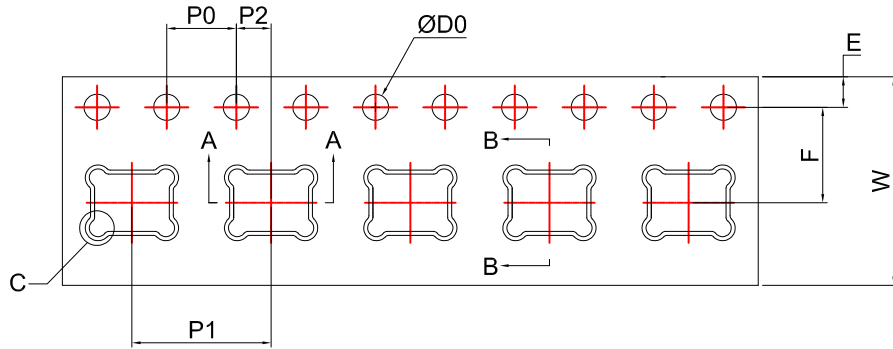

ITEM	W	E	F	ØD0	K0
DIM(mm)	12.00±0.30	1.75±0.10	5.50±0.10	1.50 ^{+0.10} ₀	1.35±0.10
ITEM	P0	10P0	P1	A0	B0
DIM(mm)	4.00±0.10	40.00±0.20	8.00±0.10	4.30±0.10	3.30±0.10
ITEM	P2	T			
DIM(mm)	2.00±0.10	0.25±0.05			

Note:

- 1) Dimensions are in mm;
- 2) Don't put the vacuum suction nozzle alignment the port hole;
- 3) Tape & Reel Per EIA-481 standard;
- 4) Label applied to external package and direct to reel;
- 5) Static voltage <100V;

Model Number	Reel Diameter	Quantity Per Reel
MSM261S4030HOR	13 inch	5700



RECOMMENDED INTERFACE CIRCUIT:

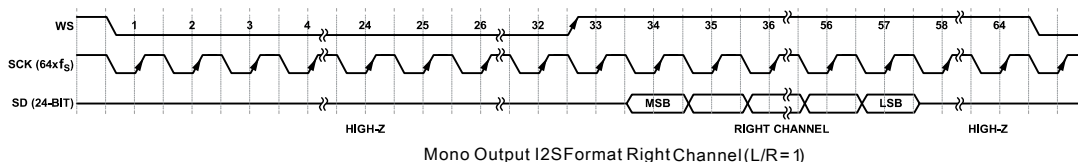
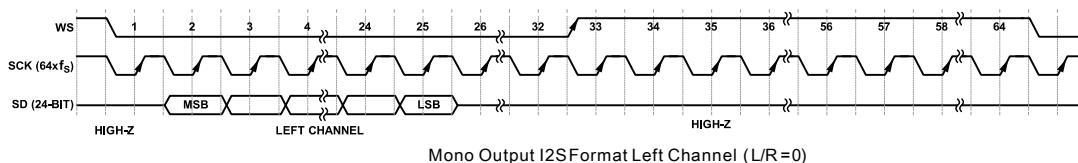
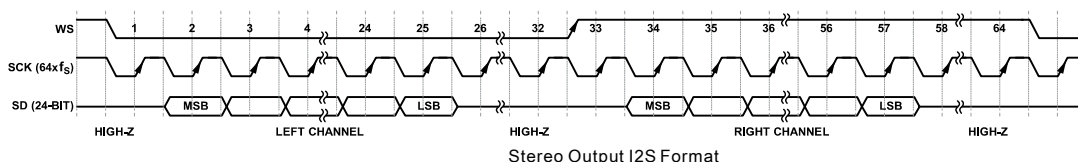
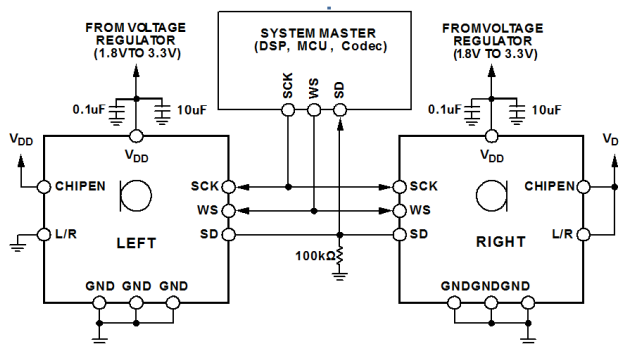

I²S DATA INTERFACE

The serial data is in slave mode I²S format, which has 24-bit depth in a 32 bit word. In a stereo frame there are 64 SCK cycles, or 32 SCK cycles per data-word. When L/R=0, the output data in the left channel, while L/R=Vdd, data in the right channel. The output data pin (SD) is tri-stated after the LSB is output so that another microphone can drive the common data line.

Data Word Length

The output data-word length is 24 bits per channel. The Mic must always have 64 clock cycles for every stereo data-word ($f_{SCK} = 64 \times f_{WS}$).

Data-Word Format

The default data format is I²S, MSB-first. In this format, the MSB of each word is delayed by



one SCK cycle from the start of each half-frame.

RELIABILITY SPECIFICATIONS

Test	Description
Thermal Shock	100 cycles air-to-air thermal shock from -40°C to +125°C with 15 minute soaks. (IEC 68-2-4)
High Temperature Storage	1,000 hours at +105°C environment (IEC 68-2-2 Test Ba)
Low Temperature Storage	1,000 hours at -40°C environment (IEC 68-2-2 Test Aa)
Reflow	5 reflow cycles with peak temperature of +260°C
ESD-HBM/LID-GND	3 discharges of ±2 kV direct contact to I/O pins. (MIL 883E, Method 3015.7)& 3 discharges of ±8 kV direct contact to lid while unit is grounded. (IEC 61000-4-2)
Vibration	4 cycles of 20 to 2,000 Hz sinusoidal sweep with 20 G peak acceleration lasting 12 minutes in X, Y and Z directions. (Mil-Std-883E, Method 2007.2 A)
Mechanical Shock	3 pulses of 10,000 G in the X, Y and Z direction (IEC 68-2-27, Test Ea)
High Temperature Bias	1,000 hours at +105°C under bias (IEC 68-2-2 Test Ba)
Low Temperature Bias	1,000 hours at -40°C under bias (IEC 68-2-2 Test Aa)
Temperature/Humidity Bias	1,000 hours at +85°C/85% R.H. under bias. (JESD22-A101A-B)
Drop Test	To be no interference in operation after dropped to 1.0cm steel plate 18 times from 1.5 meter height

NOTE: Sensitivity should vary within ±3dB from initial sensitivity. (The measurement to be done after 2 hours of conditioning at 20±2°C, R.H 60%~70%)

MSM261S4030HOR
I²S digital output MEMS microphone



苏州敏芯微电子技术股份有限公司
MEMSensing Microsystems (Suzhou, China) Co., Ltd.



REVISION HISTORY:

Revision	Subjects (major changes since last revision)	Date
0.8	Preliminary Edition	2017-02-14
1.0	Initial release	2017-05-02
1.1	Update packaging detail	2017-10-24

公司销售、技术支持联系方式

(<http://www.memsensing.com>)

For English:

MEMSensing Microsystems(Suzhou,China)
Co. Ltd.

No. 99 Jinji Lake Avenue, Bldg. NW-09, Suite 501
Suzhou Industrial Park, China 215123

Phone: +86 512 62956055

Fax: +86 512 62956056

中文用户:

苏州敏芯微电子技术股份有限公司

苏州工业园区金鸡湖大道 99 号, NW-09 楼, 501 室
中国 215123

电话: +86 512 62956055

传真: +86 512 62956056

Disclaimer: specifications and characteristics are subject to change without notice. MEMSensing Microsystems Co. Ltd. assumes no liability to any customer, licensee or any third party for any damages or any kind of nature whatsoever related to using this technical data.