

RoHS

SPECIFICATIONS

Rated Current:1.5AMP
 Contact Resistance:20mΩ Max
 Withstand Voltage:500V AC/DC
 Insulation Resistance:1000MΩ Min
 Operation Temperature:−40°c to +105°c
 Contact Material:Brass
 Contact Plating:Au Over Ni
 Insulator Material:Polyester(UL94V-0)
 Standard: PA6T
 Max.Processing Temp: 230°C for 30-60 seconds
 (260°C for 10 seconds)

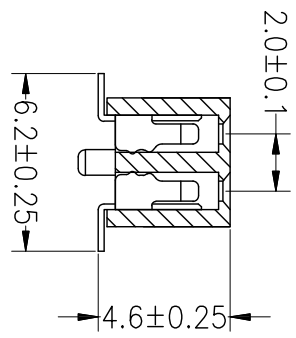
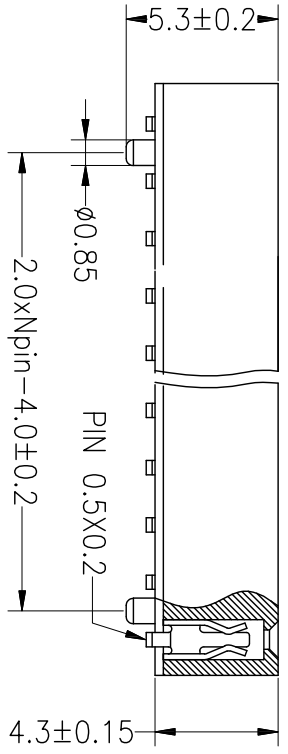
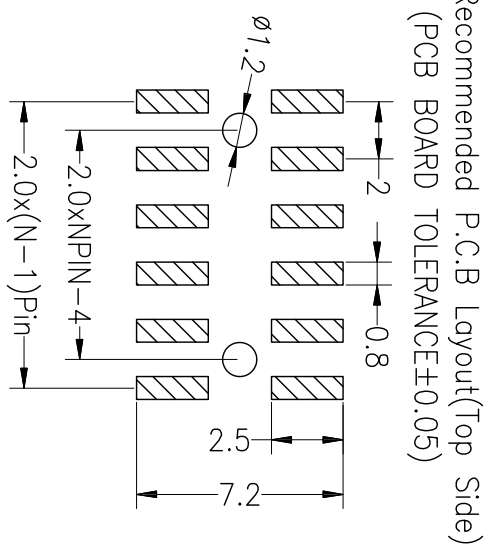
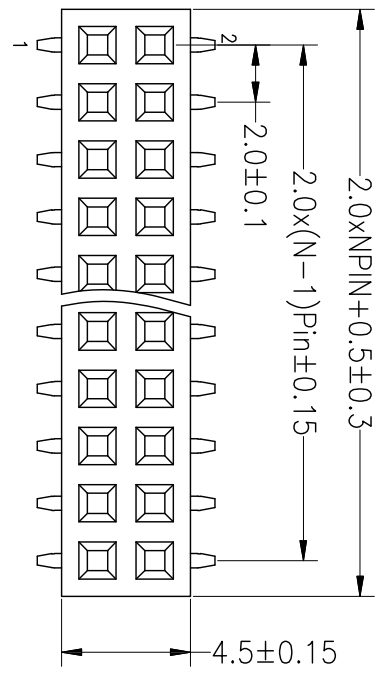

OPERATION		DRAW		SCALE		FIT		深圳市连盛精密连接器有限公司 PART NO. FH-00684 TITLE: 2.0FH H4.3mm 2x30pin SMT W4.50 带 柱	
X.X	±0.30	CHECK		UNIT	mm	A4			
X.XX	±0.20	CHECK		SIZE	A4	SHEET 1/1			
X.XXX	±0.10	CHECK		ANGLE	±3°	SHEET 1/1		PART NO. FH-00684	
REV	DATE	MODIFICATION DESCRIPTION		CHANGE	DIM	TOL	APPROVE	TITLE: 2.0FH H4.3mm 2x30pin SMT W4.50 带 柱	
1				4				8	