

Dual Low-Voltage H-Bridge IC

Feature

- **Dual H-Bridge Motor Driver**
 - **Capable of Driving Two DC Motors or One Stepper Motor**
 - **Low-MOSFET ON-Resistance:**
HS+LS 305 mΩ
- **1.5 A Maximum Drive Current Per H-Bridge**
- **Configure Bridges Parallel for 3 A Drive Current**
- **Separate Motor and Logic-Supply Pins**
 - **0V to 11V Motor-Operating Supply-Voltage**
 - **2V to 7V Logic Supply-Voltage**
- **Flexible PWM or PHASE/ENABLE Interface**
- **Low-Power Sleep Mode With 95nA Maximum Supply Current**
- **DFN 2mm x 3mm -12L Package**

Applications

- **Battery-Powered:**
 - **Cameras**
 - **DSLR Lenses**
 - **Consumer Products**
 - **Toys**
 - **Robotics**
 - **Medical Devices**

General Description

The HT8835 provides an integrated motor driver solution for cameras, consumer products, toys, and other low-voltage or battery-powered motion control applications. The device has two H-bridge drivers, and drives two DC motors or one stepper motor, as well as other devices like solenoids. The output driver block for each consists of N-channel power MOSFETs configured as an H-bridge to drive the motor winding. An internal charge pump generates gate drive voltages. The HT8835 supplies up to 1.5A of output current per H-bridge and operates on a motor power supply voltage from 0V to 11V, and a device power supply voltage of 2V to 7V.

PHASE/ENABLE and IN/IN interfaces are compatible with industry-standard devices.

Internal shutdown functions are provided for overcurrent protection, short circuit protection, under voltage lockout, and over temperature.

The HT8835 is packaged in a 12-pin DFN package.

Absolute Maximum Ratings

(If out of these ratings, the filter may be fail or damaged)

Table 1

SYMBOL	PARAMETER	MIN	MAX	UNITS
V _M	Motor power supply voltage	-0.3	12	V
V _{CC}	Power supply voltage	-0.3	7	V
T _A	Operating ambient Temperature Range	-40	125	°C
T _{STG}	Storage Temperature	-65	150	°C

Recommended Operating Conditions

Table 2

SYMBOL	PARAMETER	MIN	MAX	UNITS
V _{CC}	Device power supply voltage	2	7	V
V _M	Motor power supply voltage	0	11	V
V _{IN}	Logic level input voltage	0	V _{CC}	V
I _{OUT}	H-bridge output current	0	1.5	A
f _{PWM}	Externally applied PWM frequency	0	250	kHz
T _A	Operating ambient Temperature Range	-40	85	°C

Thermal Information

Table 3

SYMBOL	PARAMETER	VALUE	UNITS
R _{JA}	Junction-to-ambient thermal resistance	65.3	°C/W
R _{JC}	Junction-to-thermal resistance	45.8	°C/W

Electrical Characteristics

 Specifications are at $T_A=+25^{\circ}\text{C}$, $V_M=5\text{V}$, $V_{CC}=3\text{V}$ (unless otherwise noted)

SYMBOL	PARAMETER	TEST CONDITIONS	SPEC			UNIT
			MIN	TYP	MAX	
I_{VM}	VM operating supply current	No PWM, no load		194		μA
		50 kHz PWM, no load		350		
I_{VMQ}	VM sleep mode supply current	$V_M=2\text{V}$, $V_{CC}=0\text{V}$, all inputs 0V		5		nA
		$V_M=5\text{V}$, $V_{CC}=0\text{V}$, all inputs 0V		10	95	
I_{VCC}	VCC operating supply current			372		μA
V_{UVLO}	VCC undervoltage lockout voltage	VCC rising		1.5		V
		VCC falling		1.7		
V_{IL}	Input low voltage				$0.3 \times V_{CC}$	V
V_{IH}	Input high voltage		$0.5 \times V_{CC}$			V
I_{IL}	Input low current	$V_{IN}=0$			5	μA
I_{IH}	Input high current	$V_{IN}=3.3\text{V}$			50	μA
R_{PD}	Pulldown resistance			100		K Ω
$R_{DS(ON)}$	HS+LS FET on resistance	$V_{CC}=3\text{V}$, $V_M=3\text{V}$, $I_O=800\text{mA}$, $T_J=25^{\circ}\text{C}$		337	400	m Ω
		$V_{CC}=5\text{V}$, $V_M=5\text{V}$, $I_O=800\text{mA}$, $T_J=25^{\circ}\text{C}$		300	360	
I_{OFF}	OFF-state leakage current				200	nA
I_{OCP}	Overcurrent protection trip level		1.6		3.5	A
t_{DEG}	Overcurrent de-glitch time			1		μs
t_{OCR}	Overcurrent protection retry time			1		ms
t_{DEAD}	Output dead time			100		ns
t_{TSD}	Thermal shutdown temperature		150	160	180	$^{\circ}\text{C}$

Timing Requirements $T_A=+25^{\circ}\text{C}$, $V_M=5\text{V}$, $V_{CC}=3\text{V}$, $R_L=20\Omega$

NO.		MIN	MAX	UNIT
1	t_1 Delay time, xPHASE high to xOUT1 low		300	ns
2	t_2 Delay time, xPHASE high to xOUT2 high		200	ns
3	t_3 Delay time, xPHASE low to xOUT1 high		200	ns
4	t_4 Delay time, xPHASE low to xOUT2 low		300	ns
5	t_5 Delay time, xENBL low to xOUTx high		200	ns
6	t_6 Delay time, xENBL low to xOUTx low		300	ns
7	t_7 Output enable time		300	ns
8	t_8 Output disable time		300	ns
9	t_9 Delay time, xINx high to xOUTx high		160	ns
10	t_{10} Delay time, xINx low to xOUTx low		160	ns
11	t_R Output rise time	30	188	ns
12	t_F Output fall time	30	188	ns

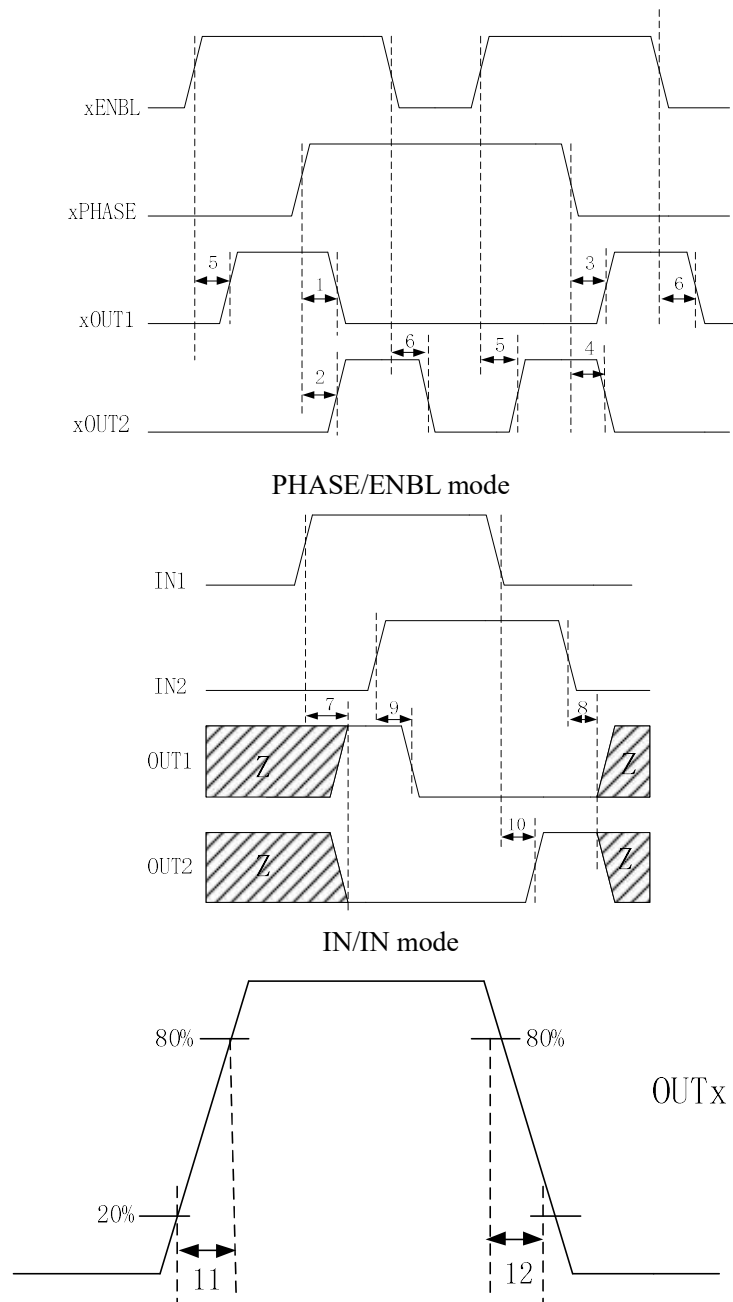

Fig. 1 Timing Requirements

PAD Definition

Fig 2. Pad definition of HT8835

Table 7. Pad definition

No.	Name	I/O	Description	EXTERNAL COMPONENTS OR CONNECTIONS
1	VM	POWER	Motor supply	Bypass to GND with 0.1μF (minimum) ceramic capacitor
2	AOUT1	O	Bridge A output 1	Connect to motor winding A
3	AOUT2	O	Bridge A output 2	
4	BOUT1	O	Bridge B output 1	Connect to motor winding B
5	BOUT2	O	Bridge B output 2	
6	GND	GROUND	Device ground	
7	BIN2/BENBL	I	Bridge B input 2/ENABLE input	IN/IN mode: Logic high sets BOUT2 high PH/EN mode: Logic high enables H-bridge B Internal pulldown resistor
8	BIN1/BPHASE	I	Bridge B input 1/PHASE input	IN/IN mode: Logic high sets BOUT1 high PH/EN mode: Sets direction of H-bridge B Internal pulldown resistor
9	AIN2/AENBL	I	Bridge A input 2/ENABLE input	IN/IN mode: Logic high sets AOUT2 high PH/EN mode: Logic high enables H-bridge A Internal pulldown resistor
10	AIN1/APHASE	I	Bridge A input 1/PHASE input	IN/IN mode: Logic high sets AOUT1 high PH/EN mode: Sets direction of H-bridge A Internal pulldown resistor
11	MODE	I	Input mode select	Logic low selects IN/IN mode Logic high selects PH/EN mode Internal pulldown resistor
12	VCC	POWER	Device supply	Bypass to GND with 0.1μF(minimum) ceramic capacitor

Feature Description

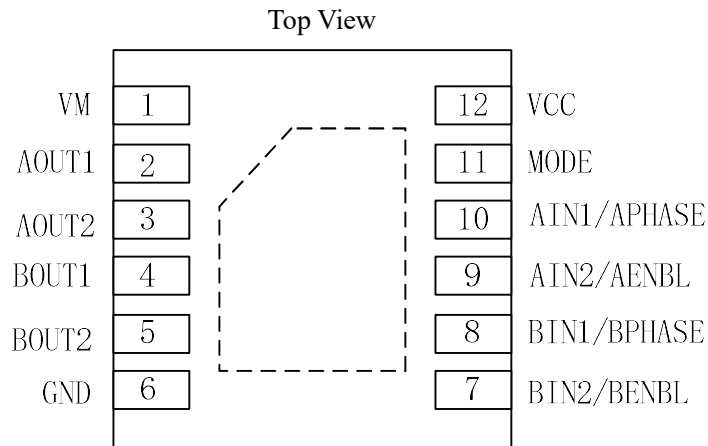
The HT8835 is an integrated motor-driver solution used for brushed motor control. The device integrates two H-bridges, and drives two DC motor or one stepper motor. The output driver block for each H-bridge consists of N-channel power MOSFETs. An internal charge pump generates the gate drive voltages. Protection features include overcurrent protection, short circuit protection, undervoltage lockout, and overtemperature protection.

The bridges connect in parallel for additional current capability.

The HT8835 allows separation of the motor voltage and logic voltage if desired. If VM and VCC are less than 7 V, the two voltages can be connected.

The mode pin allow selection of either a PHASE/ENABLE or IN/IN interface.

Protection Circuits

The HT8835 is fully protected against undervoltage, overcurrent, and overtemperature events.

1) Overcurrent Protection (OCP)

An analog current limit circuit on each FET limits the current through the FET by removing the gate drive. If this analog current limit persists for longer than the OCP time, all FETs in the H-bridge disable. After approximately 1 ms, the bridge re-enable automatically.

Overcurrent conditions on both high-side and low-side devices; a short to ground, supply, or across the motor winding result in an overcurrent shutdown.

2) Thermal Shutdown (TSD)

If the die temperature exceeds safe limits, all FETs in the H-bridge disable. Operation automatically resumes once the die temperature falls to a safe level.

3) Undervoltage Lockout (UVLO)

If at any time the voltage on the VCC pins falls below the undervoltage lockout threshold voltage, all circuitry in the device disable, and internal logic resets. Operation resumes when VCC rises above the UVLO threshold.

Table 1. Device Protection

FAULT	CONDITION	ERROR REPORT	H-BRIDGE	INTERNAL CIRCUITS	RECOVERY
VCC undervoltage (UVLO)	$VCC < VUVLO$	None	Disabled	Disabled	$VCC > VUVLO$
Overcurrent (OCP)	$IOUT > IOCP$	None	Disabled	Operating	tOCR
Thermal Shutdown (TSD)	$TJ > TTSD$	None	Disabled	Operating	$TJ < TTSD - THYS$

Device Functional Modes

The HT8835 is active when the VCC is set to a logic high. When in sleep mode, the H-bridge FETs are disabled (HIGH-Z).

OPERATING MODE	CONDITION	H-BRIDGE	INTERNAL CIRCUITS
Operating	nSLEEP high	Operating	Operating
Sleep mode	nSLEEP low	Disabled	Disabled
Fault encountered	Any fault condition met	Disabled	See Table 1

1) Bridge Control

Two control modes are available in the HT8835: IN/IN mode, and PHASE/ENABLE mode. IN/IN mode is selected if the MODE pin is driven low or left unconnected; PHASE/ENABLE mode is selected if the MODE pin is driven to logic high. Table 3 and Table 4 show the logic for these modes.

Table 3. IN/IN Mode

MODE	xIN1	xIN2	xOUT1	xOUT2	FUNCTION (DC MOTOR)
0	0	0	Z	Z	Coast
0	0	1	L	H	Reverse
0	1	0	H	L	Forward
0	1	1	L	L	Brake

Table 4. Phase/Enable Mode

MODE	xENABLE	xPHASE	xOUT1	xOUT2	FUNCTION (DC MOTOR)
1	0	X	L	L	Brake
1	1	1	L	H	Reverse
1	1	0	H	L	Forward

2) Sleep Mode

If the VCC pin reaches 0 V, the HT8835 enters a low-power sleep mode. In this state all unnecessary internal circuitry powers down. For minimum supply current, all inputs should be low (0 V) during sleep mode.

Application and Implementation

Application Information

The HT8835 is used in one or two motor control applications. Configure the HT8835 in parallel to provide double the current to one motor. The following design procedure can be used to configure the HT8835 in a brushed motor application.

Typical Application

The two H-bridges in the HT8835 drivers 1x Stepper motor or 2x DC motor. Figure 2 shows the connections.

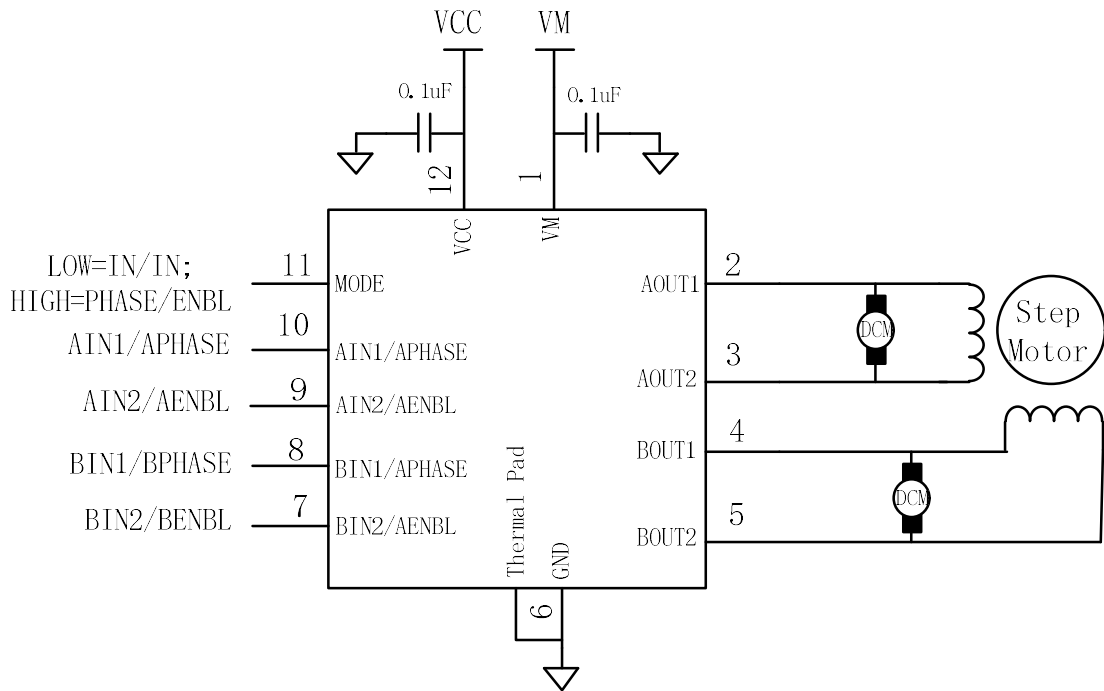

Fig.2 Drivers 1x Stepper motor or 2x DC motor

The two H-bridges in the HT8835 connect in parallel for double the current of a single H-bridge. Figure 6 shows the connections.

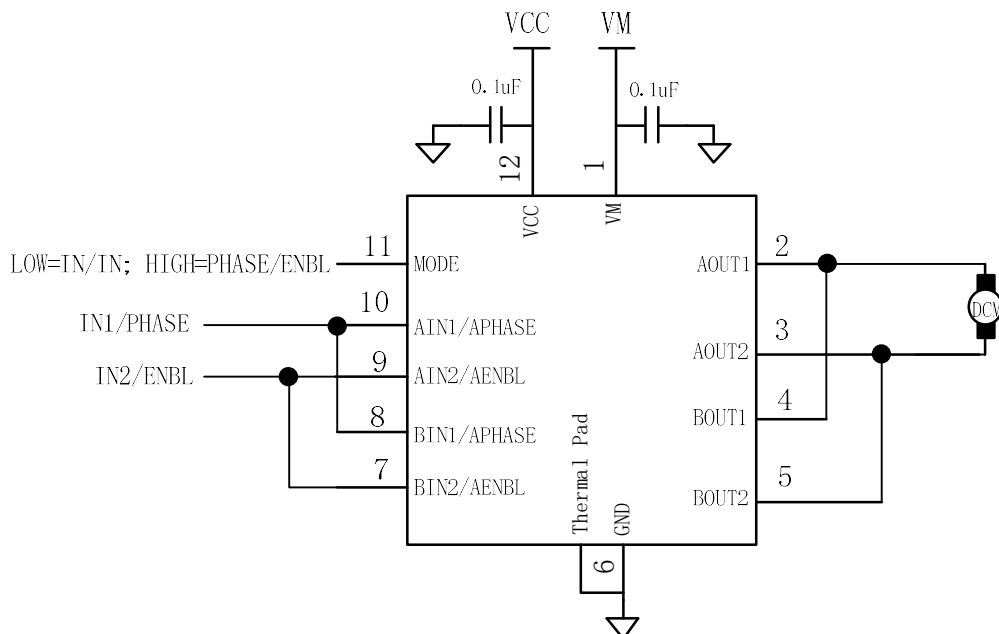
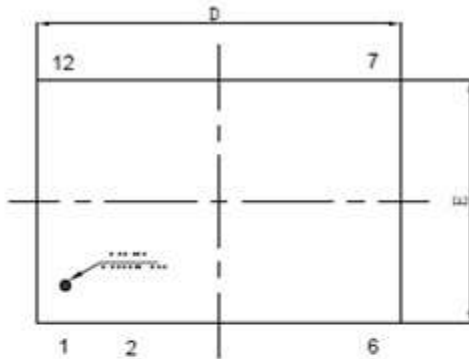

Fig.3 Parallel Mode Connections

Package
DFN 2*3-12L

Symbol	Millimeters		
	MIN	NOM	MAX
A	0.70	0.75	0.80
A1	0	0.02	0.05
b	0.20	0.25	0.30
b1	0.18REF		
c	0.203REF		
D	2.90	3.00	3.10
D2	1.90	2.00	2.10
E	1.90	2.00	2.10
E2	0.80	0.90	1.00
E3	0.60	0.70	0.80
E4	0.10	0.20	0.30
e	0.50BSC		
Nd	2.50BSC		
L	0.25	0.30	0.35
R	0.05	0.10	0.15
K	0.25REF		



TOP VIEW

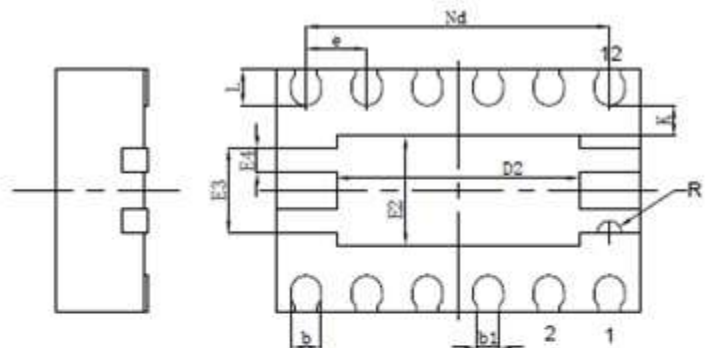

BOTTOM VIEW

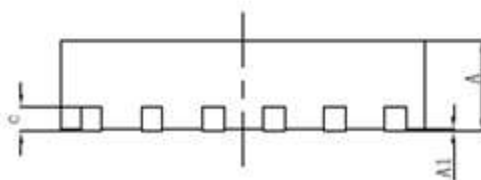

SIDE VIEW