

Features

- 80W peak pulse power per line ($t_P = 8/20\mu s$)
- Replacement for MLV(0402)
- Bidirectional configurations
- Response time is typically $< 1ns$
- Low clamping voltage
- RoHS compliant
- Transient protection for data lines to
- IEC61000-4-2(ESD) $\pm 15KV$ (air), $\pm 8KV$ (contact);
- IEC61000-4-4 (EFT) 40A (5/50ns)

Mechanical Characteristics

- DFN1006-2L package(0402)
- Lead Finish:Matte Tin
- UL Flammability Classification Rating 94V-0

Applications

Cellular phones
Portable devices
Digital cameras
Power supplies

Ordering Information

Part Number	Qty per Reel	Reel Size
ESD5V0B15H-1006	10000	7"

Dimensions and Pin Configuration

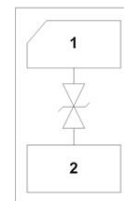
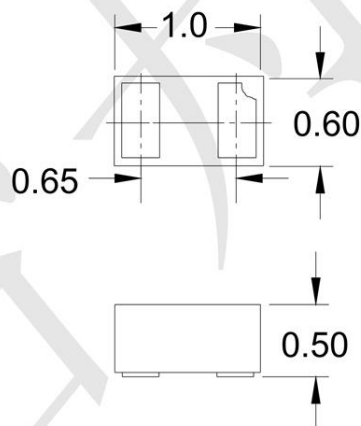

Absolute Maximum Ratings (Tamb=25°C unless otherwise specified)

Parameter	Symbol	Value	Unit
ESD per IEC 61000-4-2 (Air)	VESD	± 15	kV
ESD per IEC 61000-4-2 (Contact)		± 8	
Operating Temperature Range	TJ	-55 to +155	°C
Storage Temperature Range	Tstg	-40 to +125	°C

Electrical Characteristics (TA=25°C unless otherwise specified)

Symbol	Parameter
V _{RWM}	Nominal Reverse Working Voltage
I _R	Reverse Leakage Current @ V _{RWM}
V _{BR}	Reverse Breakdown Voltage @ I _T
I _T	Test Current for Reverse Breakdown
V _C	Clamping Voltage @ I _{PP}
I _{PP}	Maximum Peak Pulse Current
C _{ESD}	Parasitic Capacitance
V _R	Reverse Voltage
f	Small Signal Frequency

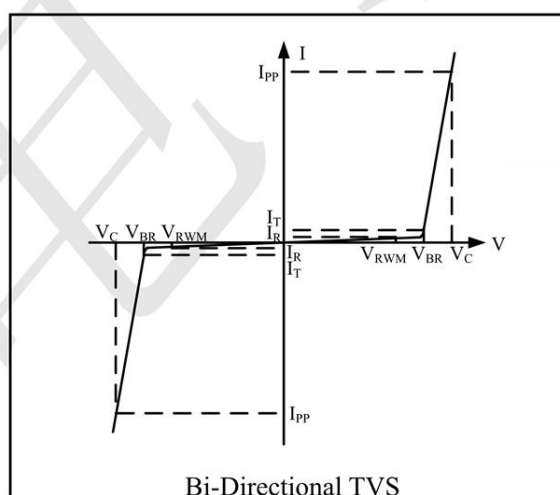

Parameter	Symbol	Conditions	Min.	Typ.	Max.	Units
Peak Reverse Working Voltage	V _{RWM}				5	V
Breakdown Voltage	V _{BR}	I _t = 1mA	5.6	6.7	7.8	V
Reverse Leakage Current	I _R	V _{RWM} = 5V T=25°C			1.0	μA
Maximum Reverse Peak Pulse Current	I _{PP}			5		A
Clamping Voltage	V _C	I _{PP} =1A			10	V
Clamping Voltage	V _C	I _{PP} =3A			13	V
Clamping Voltage	V _C	I _{PP} =5A			15	V
Junction Capacitance	C _j	V _R =0V f = 1MHz		15		pF

Characteristic Curves

Fig1. 8/20 μ s Pulse Waveform

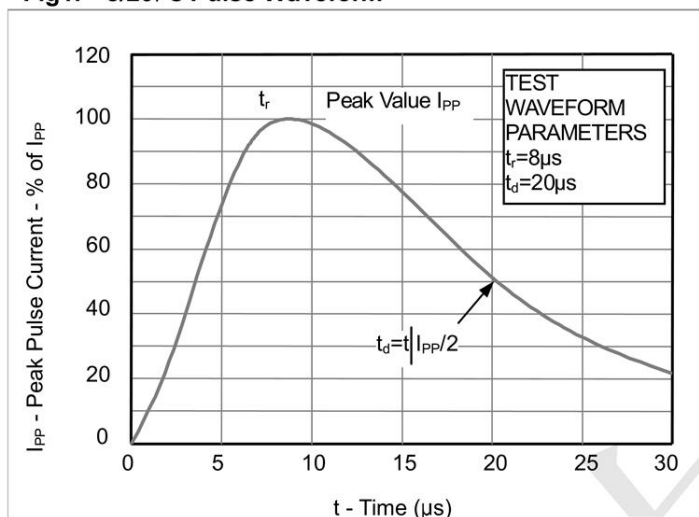

Fig2. ESD Pulse Waveform (according to IEC 61000-4-2)

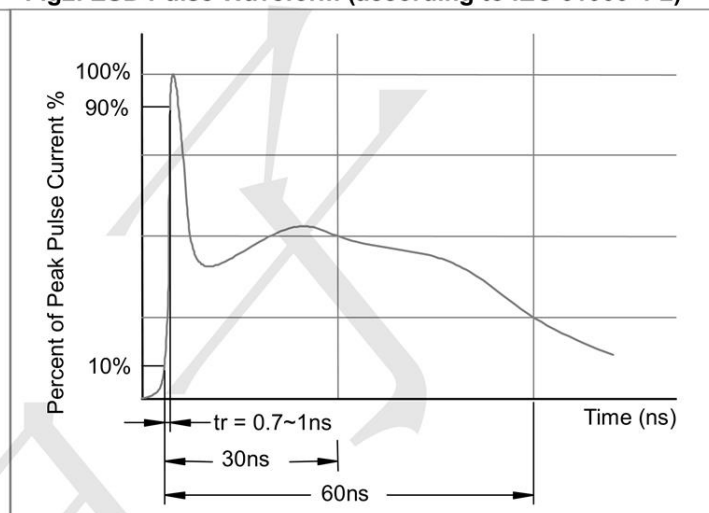
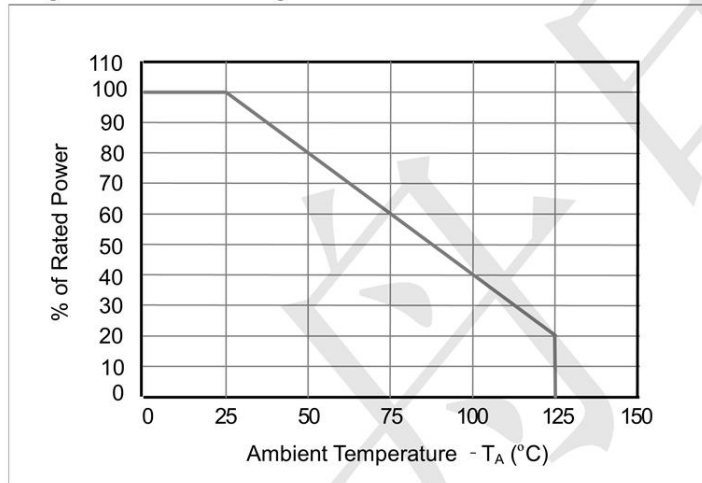
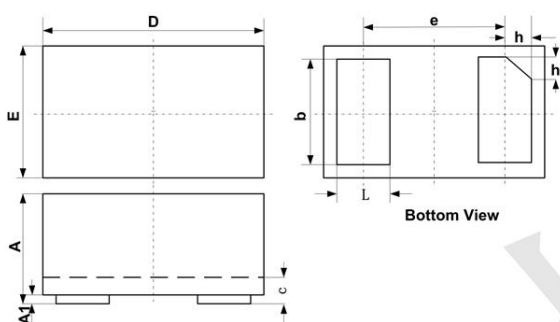

Fig3. Power Derating Curve



Outline Drawing - DFN1006-2(0402)



SYM	DIMENSIONS					
	MILLIMETERS			INCHES		
	MIN	NOM	MAX	MIN	NOM	MAX
A	0.45	0.50	0.55	0.018	0.020	0.022
A1	0.00	0.02	0.05	0.000	0.001	0.002
b	0.45	0.50	0.55	0.018	0.020	0.022
c	0.12	0.15	0.18	0.005	0.006	0.007
D	0.95	1.00	1.05	0.037	0.039	0.041
e	0.65 BSC			0.026 BSC		
E	0.55	0.60	0.65	0.022	0.024	0.026
L	0.20	0.25	0.30	0.008	0.010	0.012
h	0.07	0.12	0.17	0.003	0.005	0.007

Land Pattern - DFN1006-2

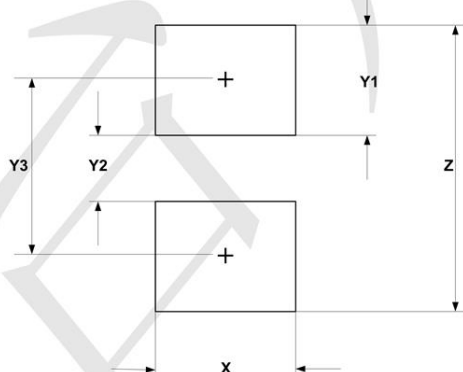

SYM	DIMENSIONS	
	MILLIMETERS	INCHES
X	0.60	0.024
Y1	0.50	0.020
Y2	0.30	0.012
Y3	0.80	0.032
Z	1.30	0.052